

Floating Ball Valves



B.F.E. s.r.l.

BONNEY FORGE

■ BFE AVAILABLE CATALOGUES



Forged Valves



Cast Steel Valves

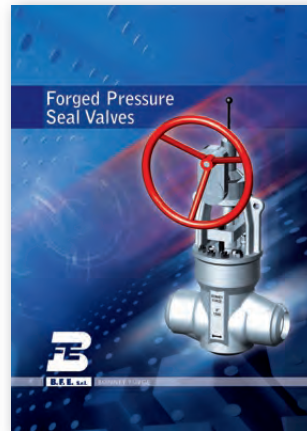

Forged Pressure Seal Valves



API 6A Valves

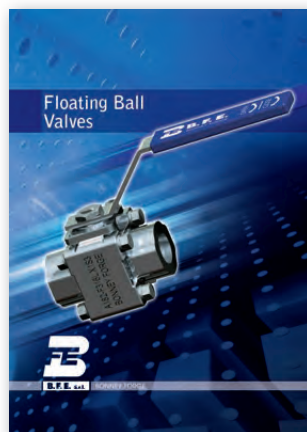

Floating Ball Valves

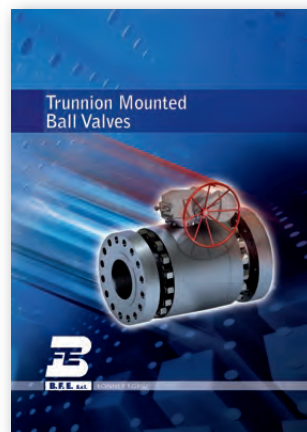

Trunnion Mounted Ball Valves

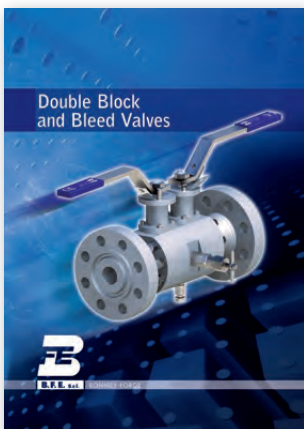

Double Block & Bleed Valves

Global quality. Total reliability. Two recurrent claims in present-day corporate strategies. But the transition from words to actions demands tangible measures. Specialization and organization underlie what amounts to a "quality culture" at BFE, not in the abstract but as a set of specific rules governing every stage of production. An operating model that is good to have in a partner who bears the responsibility of supplying valves that are essential to plant safety and regulation.



**DESIGN, CONSTRUCTION,
MARKING FOR FLOATING BALL VALVES** 4

**FULL BORE FLOATING BALL VALVES
BASIC CONFIGURATION
THREADED AND WELDING ENDS VALVES** 6

**REDUCED BORE FLOATING BALL VALVES
BASIC CONFIGURATION
THREADED AND WELDING ENDS VALVES** 7

**FULL BORE FLOATING BALL VALVES
BASIC CONFIGURATION
ASME INTEGRAL FLANGED VALVES** 8

**REDUCED BORE FLOATING BALL VALVES
BASIC CONFIGURATION
ASME INTEGRAL FLANGED VALVES** 9

**FULL BORE FLOATING BALL VALVES
CRYOGENIC CONFIGURATION
THREADED AND WELDING ENDS VALVES** 10

**REDUCED BORE FLOATING BALL VALVES
CRYOGENIC CONFIGURATION
THREADED AND WELDING ENDS VALVES** 11

**FULL BORE FLOATING BALL VALVES
CRYOGENIC CONFIGURATION
ASME INTEGRAL FLANGED VALVES** 12

REDUCED BORE FLOATING BALL VALVES CRYOGENIC CONFIGURATION ASME INTEGRAL FLANGED VALVES	13
FULL BORE FLOATING BALL VALVES HIGH TEMPERATURE & EROSION SERVICE CONFIGURATION THREADED AND WELDING ENDS VALVES	14
REDUCED BORE FLOATING BALL VALVES HIGH TEMPERATURE & EROSION SERVICE CONFIGURATION THREADED AND WELDING ENDS VALVES	14
FULL BORE FLOATING BALL VALVES HIGH TEMPERATURE & EROSION SERVICE CONFIGURATION ASME INTEGRAL FLANGED VALVES	15
REDUCED BORE FLOATING BALL VALVES HIGH TEMPERATURE & EROSION SERVICE CONFIGURATION ASME INTEGRAL FLANGED VALVES	16
VALVE SEAT & GASKET MATERIAL SELECTION GUIDE	17
CRYOGENIC CONFIGURATION	20
METAL SEATED CONFIGURATION	20
OTHER SPECIAL SERVICES	20
GENERAL SALE CONDITIONS	21

DESIGN, CONSTRUCTION, MARKING FOR FLOATING BALL VALVES

PRODUCT OVERVIEW

BFE manufactures the most complete line of quality ball valves, and can provide the exact ball valves and actuators to meet the most demanding application requirements.

Our Floating Ball Valves are available in an extensive range of designs, materials, sizes and pressure classes and are in full conformance with ANSI, API and NACE specifications.

All ball valves are designed in accordance with ASME B16.34 and API 608 and where applicable with API 6D or BS EN ISO 17292.

The BFE family of floating ball valves provides positive shut-off of fluids and gases under extreme service conditions.

BFE uses only high-quality materials inspected & tested to International Standards and utilizes advanced manufacturing technology with special emphasis on safety, quality, and long service life of our products, to ensure that our clients receive the “best in class” products available from us at a competitive price and delivered on time.

Forging material has increased strength under maximum rated operation pressure compared with cast.

Other forging properties include greater impact resistance, resistance to fatigue cracking, particularly when cycling at either high or cryogenic temperature. Overdesigned wall thickness and adaptation of high strength tie bolts convenient for valve maintenance and sufficient pipe stress.

The internal parts of valve are carefully designed and selected to ensure reliability under many conditions.

Since a variety of materials are available, BFE valves can be used with various fluids and gases including petroleum based oils and some water glycols.

The design of BFE ball valves is based on the “floating ball” principle which allows the ball to turn freely between the ball seals.

A positive seal is attained by fluid pressure acting on the upstream surface of the ball and producing a constant uniform contact between the downstream ball seal and the ball.

The ball is operated by a sealed spindle with a projecting square end to which the control handle or optional actuator is attached.

Ball valves are intended to be used as on/off flow control devices and are not to be used to throttle fluid flow. The valves should always be either fully open or closed.

BFE Floating Ball Valve design is developed using the latest software based analysis tools.

At the design stage, all projects are analysed using 3D solid modelling tools. Benefits include reduction of development time and cost, improved product quality, and ability to solve field problems for customers. Product flexibility and accuracy is assured.

Finite Element Analysis (FEA) is a very important step at the development stage to ensure the best possible performance requirements.

Valves operational problems, pressure/temperature-related deformations and flow-related forces within a valve can be evaluated.

BFE uses the FEA for predicting failure due to unknown stresses by showing problem areas in a material and allowing designers to see all of the theoretical stresses within.

During any analysis project, it is the responsibility of the BFE analyst to verify analysis results. Understanding the response of a structure or manufactured product allows effective design decisions to be made in developing structures and products that are functional, meet all engineering requirements, and can be manufactured and assembled.

Computational Fluid Dynamics (CFD) is used to simulate operating flow conditions.

Evaluation of Valve CV coefficient and convective heat transfer coefficient takes place at the design stage.

MAIN FEATURES

Fire-Safe Test Approved

BFE floating ball valves are designed in accordance with API 607 & API SPEC 6FA. When non-metal seats are destroyed in a fire, the upstream medium pressure push the ball into the downstream metal seat lip to cut off the

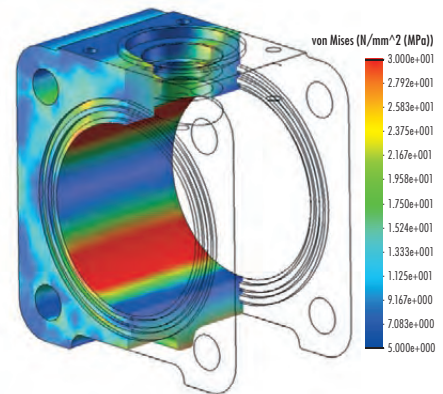

line fluid and prevent internal leakage due to a secondary metal-to-metal seals. When the first soft seal is damaged, body/gland/stem gasket will and prevent external fluid leakage.

Double Body Gasket

All BFE floating ball valves are equipped with two body gaskets. The first body gasket is a soft material and the second is graphite (if not otherwise required), this combination assures the best seal characteristic in corrosive service as a fire safe design.

Anti-Static Device

In order to prevent static electricity, a static-conduction spring is used between the stem and the ball.

Anti Blow-Out Proof Stem

The stem is designed with integral T-Type shoulder to provide blow-out proof protection. The design assures that the stem cannot be blown out of the body if the gland is removed while the valve is under pressure.

Controlled Stem & Stuffing Box Finish

Stem and stuffing box finish machining is a key point of control. The stem is made by cold rolling and stem surface finish is Ra=0.4, to ensure the seal. The stuffing box surface is Ra=1.6 for better sealing performance.

Solid Ball

The solid ball used by BFE provides straight through flow and real full-port performance characteristics. Hollow ball or cored cavity ball are not used for BFE products.

Longevity of Life

Special consideration was devoted to the attainment of enhanced life and operation of our valve throughout design, development, testing and manufacturing stages. Valve designs combined with the selection of advanced materials are such that long periods of inactivity should not affect the operation.

Low Torque Output

Seat designs, stem-bearing system and stem seal arrangements ensure consistent minimal torque values.

Flow Capacity

Valve design allows for high flow capacity in liquid or gas services regardless of whether the media is clean or dirty. Full port valves allow for pigging and ensure maximum flow capacity.

Field Repairable

Simple user friendly design allows for quick and

easy part replacement requiring minimal "Down Time".

ISO Flange Integrated in the Body Design

ISO 5211 mounting always integrated in the forged body as standard design.

INSPECTION AND TESTING

Every valve is subjected on routine base to different non-destructive testing, like the dye penetrant test on butt weld ends, on all hard faced and cladding areas.

Non-destructive test are also carried out on the critical areas as defined by ASME B16.34.

Optional examinations like:

Radiographic

Magnetic particules

Ultrasonic

Helium leak test

Personnel performing NDT are trained and qualified to EN 473/ ASNT-SNT-TC-1A.

Every valve is subject to a pressure test in

accordance with the standard API 598 or BS 6755 Part.1.

The rated pressure for the applicable pressure class is in accordance with ASME B16.34 and EN 12516-1/-2.

MARKING AND IDENTIFICATION

Each valve is identified on proper name plate and on valve body as required by MSS SP-25 and ASME B16.34. Name plate carries all information on rating, size, valve body and trim material, customer tags.

On body, marking includes material designations (per ASTM) and heat code and of course the trade mark.

AVAILABLE OPTIONS

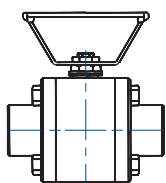

OVAL SAFETY HANDLE

Oval safety handwheels are used where the standard lever can be accidentally bumped open or closed.

The oval safety handle can be either carbon steel or stainless steel.

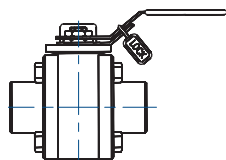

LOCKING DEVICE

Locking device is supplied as option in order to prevent unauthorized opening/closing.

BFE locking device can lock the valve in either the open or closed position and cannot be branched by removing the lever.

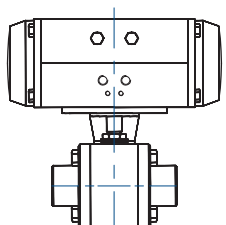

EASY AUTOMATION - PNEUMATIC ACTUATOR

BFE floating ball valves are available with pre-assembled valve/pneumatic actuator packages. In any case BFE standard design allows users to direct mount most brands of valve actuators with the need of an additional bracket always available in the factory.

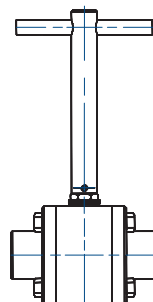

"T"-HANDLE

"T"-handle is usually used where acces to the valve is limited and can be supplied for vertical or horizontal valve installation.

The "T"-handle can be either carbon steel or stainless steel.

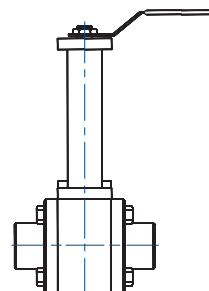

EXTENDED BONNET FOR INSULATION

BFE floating ball valve can be supplied with an extended bonnet to allow insulation up to 3 inches (76mm) thick. The insulation can be installed all around the valve without blocking access to the valve valve or other operator.

FULL BORE FLOATING BALL VALVES

BASIC CONFIGURATION

THREADED AND WELDING ENDS VALVES

WORKING PRESSURE RATING	SIZE		STANDARD DESIGN TYPE	A		A-IN		A-WN		B		C		H		WEIGHT		FIGURE
	NPS	DN		mm	in	mm	in	mm	in	mm	in	mm	in	mm	in	kg	lb	
ASME 600	2"	50	2	150	5.91	298	11.73	350	13.78	49	1.93	360	14.2	137	5.4	8.5	18.7	6H 708
	3"	80	2	300	11.81	300	11.81	500	19.69	76	2.99	450	17.7	184	7.2	26	57.3	6H 710
ASME 800	3/8"	10	1	75	2.95	N.A.	N.A.	N.A.	N.A.	11	0.43	160	6.3	73	2.9	1	2.2	HN 702
	1/2"	15	1	80	3.15	N.A.	N.A.	N.A.	N.A.	14	0.55	160	6.3	76	3.0	1.3	2.9	HN 703
	3/4"	20	1	100	3.94	N.A.	N.A.	N.A.	N.A.	20	0.79	195	7.7	108	4.3	2.4	5.3	HN 704
	1"	25	1	110	4.33	N.A.	N.A.	N.A.	N.A.	25.4	1.00	195	7.7	111	4.4	3.1	6.8	HN 705
	1-1/4"	32	1	120	4.72	N.A.	N.A.	N.A.	N.A.	32	1.26	260	10.2	125	4.9	4.5	9.9	HN 706
	1-1/2"	40	1	140	5.51	N.A.	N.A.	N.A.	N.A.	38	1.50	360	14.2	130	5.1	6.8	15.0	HN 707
	2"	50	2	170	6.69	300	11.81	370	14.57	49	1.93	360	14.2	154	6.1	12	26.4	H 708
ASME 900	3/8"	10	1	75	2.95	236	9.29	275	10.83	11	0.43	160	6.3	73	2.9	1	2.2	90HN 702
	1/2"	15	1	80	3.15	239	9.41	280	11.02	14	0.55	160	6.3	76	3.0	1.3	2.9	90HN 703
	3/4"	20	1	100	3.94	250	9.84	300	11.81	20	0.79	195	7.7	108	4.3	2.4	5.3	90HN 704
	1"	25	2	110	4.33	261	10.28	310	12.20	25.4	1.00	195	7.7	111	4.4	3.1	6.8	90H 705
	1-1/4"	32	2	120	4.72	270	10.63	320	12.60	32	1.26	260	10.2	125	4.9	4.5	9.9	90H 706
	1-1/2"	40	2	140	5.51	279	10.98	340	13.39	38	1.50	360	14.2	130	5.1	6.8	15	90H 707
ASME 1500	3/8"	10	2	100	3.94	259	10.20	300	11.81	11.1	0.44	195	7.7	100	3.9	3	6.6	15H 702
	1/2"	15	2	100	3.94	259	10.20	300	11.81	11.1	0.44	195	7.7	100	3.9	3	6.6	15H 703
	3/4"	20	2	125	4.92	272	10.71	325	12.80	15.5	0.61	195	7.7	107	4.2	4.8	10.5	15H 704
	1"	25	2	140	5.51	285	11.22	340	13.39	21	0.83	260	10.2	121	4.8	7.7	17	15H 705
	1-1/4"	32	2	170	6.69	305	12.01	370	14.57	34	1.34	360	14.2	154	6.1	14	30.9	15H 706
	1-1/2"	40	2	170	6.69	305	12.01	370	14.57	34	1.34	360	14.2	154	6.1	14	30.9	15H 707
	2"	50	2	200	7.87	320	12.60	400	15.75	43	1.69	360	14.2	162	6.4	19.3	42.5	15H 708
ASME 2500	3/8"	10	2	100	3.94	259	10.20	300	11.81	11.1	0.44	195	7.7	100	3.9	3	6.6	25H 702
	1/2"	15	2	100	3.94	259	10.20	300	11.81	11.1	0.44	195	7.7	100	3.9	3	6.6	25H 703
	3/4"	20	2	125	4.92	272	10.71	325	12.80	15.5	0.61	195	7.7	107	4.2	4.8	10.5	25H 704
	1"	25	2	140	5.51	285	11.22	340	13.39	21	0.83	260	10.2	105	4.1	7.7	17.0	25H 705

PRODUCT FEATURES:

- Live Loaded Stem Seal.
- Phosphate coated carbon steel valve body/closure.
- ISO 5211 mounting integrated in the forged body.
- Anti-static Device.
- Blow-out Proof stem.
- Fire-Safe.
- Cavity Pressure relief seat design.
- Standard O-Rings in Viton with AED properties.

DESIGN TYPE 1

3-PIECE & SWING-OUT BODY

Standard design available with Threaded/ Socked-Weld/Butt-Welding ends.

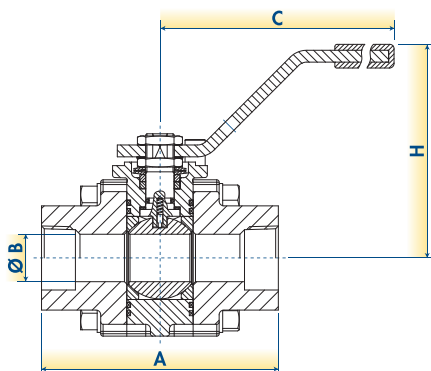

DESIGN TYPE 2

3-PIECE & ENCAPSULATED SEAT

Standard design available with threaded ends. Socked-weld and butt-welding ends are available only with nipple.

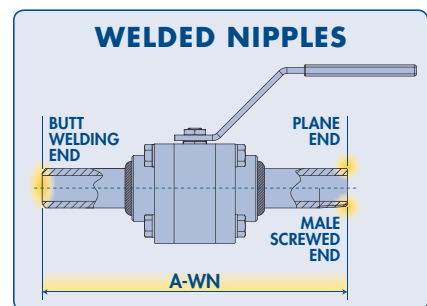
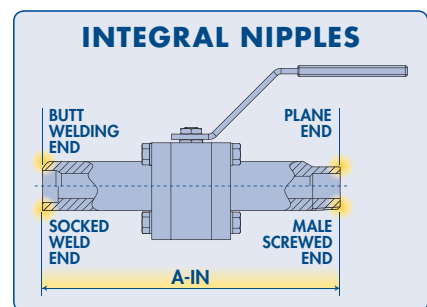
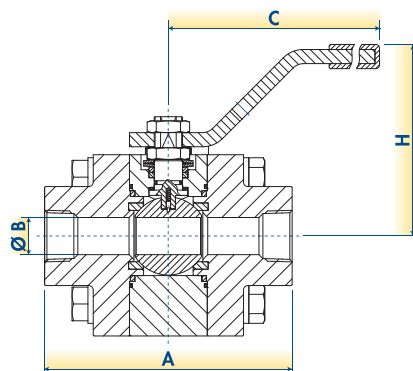

REDUCED BORE FLOATING BALL VALVES

BASIC CONFIGURATION

THREADED AND WELDING ENDS VALVES

WORKING PRESSURE RATING	SIZE		STANDARD DESIGN TYPE	A		A-IN		A-WN		B		C		H		WEIGHT		FIGURE
	NPS	DN		mm	in	mm	in	mm	in	mm	in	mm	in	mm	in	kg	lb	
ASME 600	3"	80	2	150	5.91	298	11.73	N.A.	N.A.	49	1.93	360	14.2	137	5.4	8.5	18.7	6HL 710
ASME 800	1/2"	15	1	75	2.95	N.A.	N.A.	N.A.	N.A.	11	0.43	160	6.3	73	2.9	1	2.2	HLN 703
	3/4"	20	1	80	3.15	N.A.	N.A.	N.A.	N.A.	14	0.55	160	6.3	76	3.0	1.3	2.9	HLN 704
	1"	25	1	100	3.94	N.A.	N.A.	N.A.	N.A.	20	0.79	195	7.7	108	4.3	2.4	5.3	HLN 705
	1-1/4"	32	1	110	4.33	N.A.	N.A.	N.A.	N.A.	25.4	1.00	195	7.7	111	4.4	3.1	6.8	HLN 706
	1-1/2"	40	1	120	4.72	N.A.	N.A.	N.A.	N.A.	32	1.26	260	10.2	125	4.9	4.5	9.9	HLN 707
	2"	50	1	140	5.51	N.A.	N.A.	N.A.	N.A.	38	1.50	360	14.2	130	5.1	6.8	15.0	HLN 708
	3"	80	2	170	6.69	300	11.81	N.A.	N.A.	49	1.93	360	14.2	154	6.1	12	26.4	HL 710
ASME 900	1/2"	15	1	75	2.95	236	9.29	275	10.8	11	0.43	160	6.3	73	2.9	1	2.2	90HLN 703
	3/4"	20	1	80	3.15	239	9.41	280	11.0	14	0.55	160	6.3	76	3.0	1.3	2.9	90HLN 704
	1"	25	1	100	3.94	250	9.84	300	11.8	20	0.79	195	7.7	108	4.3	2.4	5.3	90HLN 705
	1-1/4"	32	2	110	4.33	261	10.28	310	12.2	25.4	1.00	195	7.7	111	4.4	3.1	6.8	90HL 706
	1-1/2"	40	2	120	4.72	270	10.63	320	12.6	32	1.26	260	10.2	125	4.9	4.5	9.9	90HL 707
	2"	50	2	140	5.51	279	10.98	340	13.4	38	1.50	360	14.2	130	5.1	6.8	15.0	90HL 708

PRODUCT FEATURES:

- Live Loaded Stem Seal.
- Phosphate coated carbon steel valve body/closure.
- ISO 5211 mounting integrated in the forged body.
- Anti-static Device.
- Blow-out Proof stem.
- Fire-Safe.
- Cavity Pressure relief seat design.
- Standard O-Rings in Viton with AED properties.

DESIGN TYPE 1

3-PIECE & SWING-OUT BODY

Standard design available with Threaded/ Socked-Weld/Butt-Welding ends.

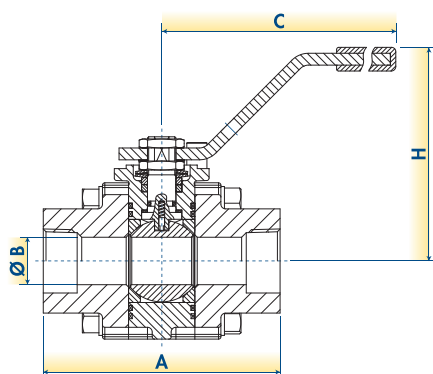

DESIGN TYPE 2

3-PIECE & ENCAPSULATED SEAT

Standard design available with threaded ends. Socked-weld and butt-welding ends are available only with nipple.

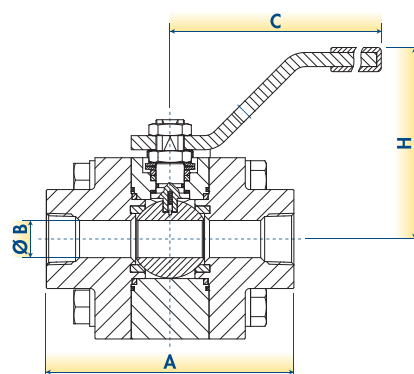

INTEGRAL NIPPLES

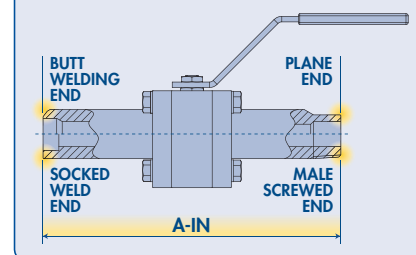

WELDED NIPPLES

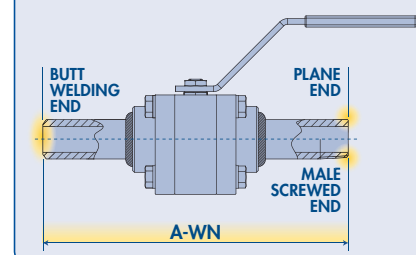

FULL BORE FLOATING BALL VALVES

BASIC CONFIGURATION

ASME INTEGRAL FLANGED VALVES

WORKING PRESSURE RATING	SIZE		STANDARD DESIGN TYPE	A-RF		A-RJ		B		B1		C		H		WEIGHT		FIGURE
	NPS	DN		mm	in	mm	in	mm	in	mm	in	mm	in	mm	in	kg	lb	
ASME 150	1/2"	15	2	108.5	4.25	N.A.	N.A.	14	0.55	N.A.	N.A.	160	6.3	76	3.0	2	4.4	1-703
	3/4"	20	2	117.5	4.62	N.A.	N.A.	20	0.79	N.A.	N.A.	195	7.7	108	4.3	3.2	7.0	1-704
	1"	25	2	127	5.00	140	5.50	25.4	1.00	N.A.	N.A.	195	7.7	111	4.4	4.6	10.1	1-705
	1-1/4"	32	2	140	5.50	153	6.00	32	1.26	N.A.	N.A.	260	10.2	125	4.9	6.2	13.7	1-706
	1-1/2"	40	2	165	6.50	178	7.00	38	1.50	N.A.	N.A.	260	10.2	130	5.1	8.2	18.1	1-707
	2"	50	2	178	7.00	191	7.50	49	1.93	N.A.	N.A.	260	10.2	137	5.4	14	30.9	1-708
	3"	80	2	203	8.00	216	8.50	76	2.99	N.A.	N.A.	450	17.7	184	7.2	29	64.0	1-710
	4"	100	1	229	9.00	242	9.50	100	3.94	N.A.	N.A.	450	17.7	203	8.0	46	101.4	1-711
6"	150	1	394	15.50	407	16.00	150	5.91	N.A.	N.A.	750	29.5	253	10.0	130	286.6	1-713	
ASME 300	1/2"	15	1	140	5.50	151	5.94	14	0.55	N.A.	N.A.	160	6.3	76	3.0	3.5	7.7	3-703
	3/4"	20	1	152	6.00	165	6.50	20	0.79	N.A.	N.A.	195	7.7	108	4.3	5	11.0	3-704
	1"	25	1	165	6.50	178	7.00	25.4	1.00	N.A.	N.A.	195	7.7	111	4.4	7	15.4	3-705
	1-1/4"	32	1	178	7.00	191	7.50	32	1.26	N.A.	N.A.	260	10.2	125	4.9	10.5	23.1	3-706
	1-1/2"	40	1	191	7.50	203	8.00	38	1.50	N.A.	N.A.	260	10.2	130	5.1	13.5	29.8	3-707
	2"	50	1	216	8.50	232	9.12	49	1.93	N.A.	N.A.	360	14.2	137	5.4	18.8	41.4	3-708
	3"	80	1	282	11.12	298	11.74	76	2.99	N.A.	N.A.	450	17.7	184	7.2	39	86.0	3-710
	4"	100	1	305	12.00	321	12.62	100	3.94	N.A.	N.A.	450	17.7	203	8.0	68	149.9	3-711
ASME 600	1/2"	15	1	165	6.50	163	6.44	14	0.55	N.A.	N.A.	160	6.3	76	3.0	4.5	9.9	6-703
	3/4"	20	1	191	7.50	191	7.50	20	0.79	N.A.	N.A.	195	7.7	108	4.3	6	13.2	6-704
	1"	25	1	216	8.50	216	8.50	25.4	1.00	N.A.	N.A.	195	7.7	111	4.4	8	17.6	6-705
	1-1/4"	32	1	229	9.00	229	9.00	32	1.26	N.A.	N.A.	260	10.2	125	4.9	12	26.4	6-706
	1-1/2"	40	1	241	9.50	241	9.50	38	1.50	N.A.	N.A.	260	10.2	130	5.1	16	35.3	6-707
	2"	50	1	292	11.50	295	11.62	49	1.93	N.A.	N.A.	360	14.2	137	5.4	22	48.5	6-708
	3"	80	1	356	14.00	359	14.12	76	2.99	N.A.	N.A.	450	17.7	184	7.2	45	99.2	6-710
	4"	100	1	371	14.50	371	14.50	100	3.94	N.A.	N.A.	450	17.7	203	8.0	68	149.9	6-711
ASME 1500	1/2"	15	1	216	8.50	216	8.50	11.1	0.44	N.A.	N.A.	195	7.7	100	4	7.1	15.6	15H 703
	3/4"	20	1	229	9.00	229	9.00	15.5	0.61	N.A.	N.A.	195	7.7	107	4.2	10.5	23.1	15H 704
	1"	25	1	254	10.00	254	10.00	21	0.83	N.A.	N.A.	260	10.2	121	4.8	17.5	38.6	15H 705
	1-1/4"	32	1	279	11.00	279	11.00	34	1.34	N.A.	N.A.	360	14.2	154	6	25.5	56.2	15H 706
	1-1/2"	40	1	305	12.00	305	12.00	34	1.34	N.A.	N.A.	360	14.2	154	6	29	63.4	15H 707
	2"	50	1	368	14.50	371	14.50	43	1.69	N.A.	N.A.	360	14.2	162	6.4	38	83.8	15H 708
ASME 2500	1/2"	15	1	264	10.38	264	10.38	11.1	0.44	N.A.	N.A.	195	7.7	100	4	10	22.0	25H 703
	3/4"	20	1	273	10.75	273	10.75	15.5	0.61	N.A.	N.A.	195	7.7	107	4.2	14	30.9	25H 704
	1"	25	1	308	12.12	308	12.12	21	0.83	N.A.	N.A.	260	10.2	121	4.8	20	44.0	25H 705

PRODUCT FEATURES:

- Live Loaded Stem Seal. • Phosphate coated carbon steel valve body/closure. • ISO 5211 mounting integrated in the forged body. • Anti-static Device. • Blow-out Proof stem. • Fire-Safe. • Cavity Pressure relief seat design. • Standard O-Rings in Viton with AED properties.

DESIGN TYPE 1

3-PIECE & ENCAPSULATED SEAT

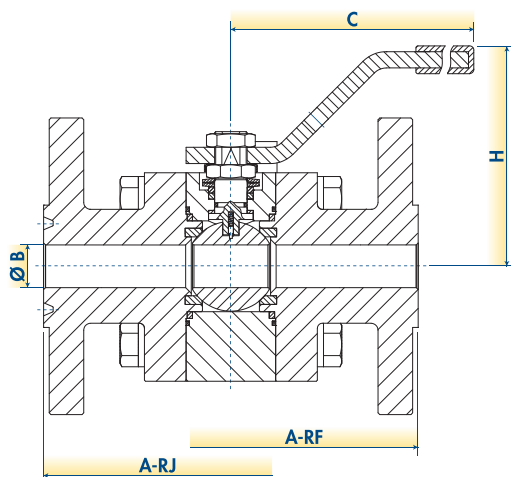

DESIGN TYPE 2

2-PIECE & ENCAPSULATED SEAT

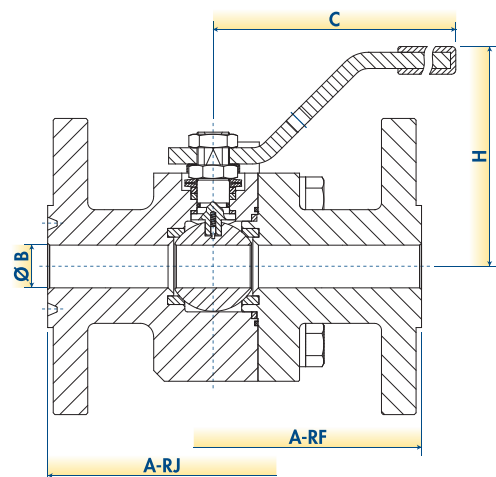

REDUCED BORE FLOATING BALL VALVES

BASIC CONFIGURATION

ASME INTEGRAL FLANGED VALVES

WORKING PRESSURE RATING	SIZE		STANDARD DESIGN TYPE	A-RF		A-RJ		B		B1		C		H		WEIGHT		FIGURE
	NPS	DN		mm	in	mm	in	mm	in	mm	in	mm	in	mm	in	kg	lb	
ASME 150	1/2"	15	1	108.5	4.25	N.A.	4.25	11	0.43	14	0.55	160	6.3	73	2.9	2.7	6.0	L1 703
	3/4"	20	1	117.5	4.62	N.A.	4.62	14	0.55	20	0.79	160	6.3	76	3.0	3.3	7.3	L1 704
	1"	25	1	127	5.00	140	5.50	20	0.79	25.4	1.00	195	7.7	108	4.3	4.5	9.9	L1 705
	1-1/4"	32	1	140	5.50	153	6.00	25.4	1.00	32	1.26	195	7.7	111	4.4	6.3	13.9	L1 706
	1-1/2"	40	1	165	6.50	178	7.00	32	1.26	38	1.50	260	10.2	125	4.9	8.8	19.4	L1 707
	2"	50	1	178	7.00	191	7.50	38	1.50	49	1.93	260	10.2	130	5.1	11.6	25.6	L1 708
	3"	80	1	203	8.00	216	8.50	49	1.93	76	2.99	260	10.2	137	5.4	22.2	48.9	L1 710
	4"	100	1	229	9.00	242	9.50	76	2.99	100	3.94	450	17.7	184	7.2	29.3	64.6	L1 711
	6"	150	1	394	15.50	407	16.00	100	3.94	150	5.91	450	17.7	203	8.0	64	141.1	L1 713
	8"	200	1	457	18.00	470	18.50	150	5.91	200	7.87	750	29.5	253	10.0	98	216	L1 714
ASME 300	1/2"	15	1	140	5.50	151	5.94	11	0.43	14	0.55	160	6.3	73	2.9	3	6.6	L3 703
	3/4"	20	1	152	6.00	165	6.50	14	0.55	20	0.79	160	6.3	76	3.0	4	8.8	L3 704
	1"	25	1	165	6.50	178	7.00	20	0.79	25.4	1.00	195	7.7	108	4.3	6	13.2	L3 705
	1-1/4"	32	1	178	7.00	191	7.50	25.4	1.00	32	1.26	195	7.7	111	4.4	8.2	18.1	L3 706
	1-1/2"	40	1	191	7.50	203	8.00	32	1.26	38	1.50	260	10.2	125	4.9	11.6	25.6	L3 707
	2"	50	1	216	8.50	232	9.12	38	1.50	49	1.93	260	10.2	130	5.1	14.8	32.6	L3 708
	3"	80	1	282	11.12	298	11.74	49	1.93	76	2.99	360	14.2	137	5.4	27	59.5	L3 710
	4"	100	1	305	12.00	321	12.62	76	2.99	100	3.94	450	17.7	184	7.2	41	90.4	L3 711
ASME 600	1/2"	15	1	165	6.50	163	6.44	11	0.43	14	0.55	160	6.3	73	2.9	3.8	8.4	L6 703
	3/4"	20	1	191	7.50	191	7.50	14	0.55	20	0.79	160	6.3	76	3.0	5	11.0	L6 704
	1"	25	1	216	8.50	216	8.50	20	0.79	25.4	1.00	195	7.7	108	4.3	7	15.4	L6 705
	1-1/4"	32	1	229	9.00	229	9.00	25.4	1.00	32	1.26	195	7.7	111	4.4	9	19.8	L6 706
	1-1/2"	40	1	241	9.50	241	9.50	32	1.26	38	1.50	260	10.2	125	4.9	13.1	28.9	L6 707
	2"	50	1	292	11.50	295	11.62	38	1.50	49	1.93	260	10.2	130	5.1	17.2	37.9	L6 708
	3"	80	1	356	14.00	359	14.12	49	1.93	76	2.99	360	14.2	137	5.4	31	68.3	L6 710
	4"	100	1	432	17.00	435	17.12	76	2.99	100	3.94	450	17.7	184	7.2	48	105.8	L6 711

PRODUCT FEATURES:

- Live Loaded Stem Seal.
- Phosphate coated carbon steel valve body/closure.
- ISO 5211 mounting integrated in the forged body.
- Anti-static Device.
- Blow-out Proof stem.
- Fire-Safe.
- Cavity Pressure relief seat design.
- Standard O-Rings in Viton with AED properties.

DESIGN TYPE 1 3-PIECE & ENCAPSULATED SEAT

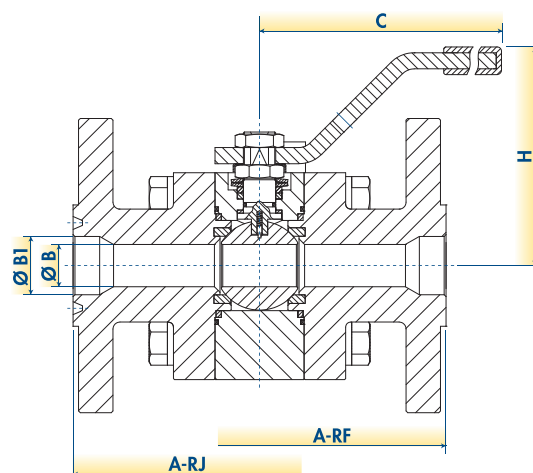

FULL BORE FLOATING BALL VALVES

CRYOGENIC CONFIGURATION

THREADED AND WELDING ENDS VALVES

WORKING PRESSURE RATING	SIZE		STANDARD DESIGN TYPE	A		A-IN		A-WN		B		C		H		WEIGHT		FIGURE
	NPS	DN		mm	in	mm	in	mm	in	mm	in	mm	in	mm	in	kg	lb	
ASME 600	2"	50	2	180	7.09	298	11.73	380	14.96	49	1.93	360	14.2	387	15.2	14.5	32.0	6C708
	3"	80	2	300	11.81	300	11.81	500	19.69	76	2.99	450	17.7	434	17.1	34	75.0	6C710
ASME 800	3/8"	10	2	100	3.94	236	9.29	300	11.81	11	0.43	160	6.3	323	12.7	2	4.4	HC 702
	1/2"	15	2	105	4.13	239	9.41	305	12.01	14	0.55	160	6.3	326	12.8	4.3	9.5	HC 703
	3/4"	20	2	115	4.53	250	9.84	315	12.40	20	0.79	195	7.7	358	14.1	6.4	14.1	HC 704
	1"	25	2	120	4.72	261	10.28	320	12.60	25.4	1.00	195	7.7	361	14.2	7.6	16.8	HC 705
	1-1/4"	32	2	130	5.12	270	10.63	330	12.99	32	1.26	260	10.2	375	14.8	9.5	20.9	HC 706
	1-1/2"	40	2	150	5.91	279	10.98	350	13.78	38	1.50	260	10.2	380	15.0	12.3	27.1	HC 707
	2"	50	2	200	7.87	300	11.81	400	15.75	49	1.93	360	14.2	404	15.9	18	39.6	HC 708
ASME 900	3/8"	10	2	100	3.94	236	9.29	300	11.81	11	0.43	160	6.3	323	12.7	2	4.4	90HC 702
	1/2"	15	2	105	4.13	239	9.41	305	12.01	14	0.55	160	6.3	326	12.8	4.3	9.5	90HC 703
	3/4"	20	2	115	4.53	250	9.84	315	12.40	20	0.79	195	7.7	358	14.1	6.4	14.1	90HC 704
	1"	25	1	120	4.72	261	10.28	320	12.60	25.4	1.00	195	7.7	361	14.2	7.6	16.8	90HC 705
	1-1/4"	32	1	130	5.12	270	10.63	330	12.99	32	1.26	260	10.2	375	14.8	9.5	20.9	90HC 706
ASME 1500	3/8"	10	1	110	4.33	259	10.20	310	12.20	11.1	0.44	195	7.7	350	13.8	4	8.8	15HC 702
	1/2"	15	1	125	4.92	259	10.20	325	12.80	11.1	0.44	195	7.7	350	13.8	6	13.2	15HC 703
	3/4"	20	1	150	5.91	272	10.71	350	13.78	15.5	0.61	195	7.7	357	14.1	8.8	19.4	15HC 704
	1"	25	1	155	6.10	285	11.22	355	13.98	21	0.83	260	10.2	371	14.6	9.2	20.3	15HC 705
	1-1/4"	32	1	180	7.09	305	12.01	380	14.96	34	1.34	360	14.2	404	15.9	19	41.9	15HC 706
	1-1/2"	40	1	180	7.09	305	12.01	380	14.96	34	1.34	360	14.2	404	15.9	19.5	43.0	15HC 707
	2"	50	1	210	8.27	320	12.60	410	16.14	43	1.69	360	14.2	412	16.2	25.3	55.8	15HC 708
ASME 2500	3/8"	10	1	125	4.92	259	10.20	325	12.80	11.1	0.44	195	7.7	350	13.8	4	8.8	25HC 702
	1/2"	15	1	125	4.92	259	10.20	325	12.80	11.1	0.44	195	7.7	350	13.8	6	13.2	25HC 703
	3/4"	20	1	140	5.51	272	10.71	340	13.39	15.5	0.61	195	7.7	357	14.1	8.8	19.4	25HC 704
	1"	25	1	150	5.91	285	11.22	350	13.78	21	0.83	260	10.2	355	14.0	9.2	20.3	25HC 705

PRODUCT FEATURES:

- Live Loaded Stem Seal. • ISO 5211 mounting integrated in the forged body. • Anti-static Device. • Blow-out Proof stem. • Fire-Safe. • Pressure equalization hole on the ball.

DESIGN TYPE 1

3-PIECE & ENCAPSULATED SEAT

Standard design available with threaded ends. Socked-weld and butt-welding ends are available only with nipple.

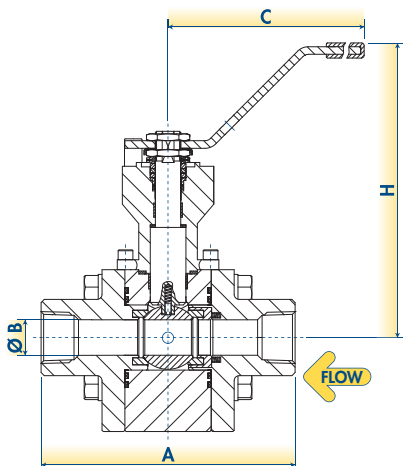

DESIGN TYPE 2

2-PIECE & ENCAPSULATED SEAT

Standard design available with threaded ends. Socked-weld and butt-welding ends are available only with nipple.

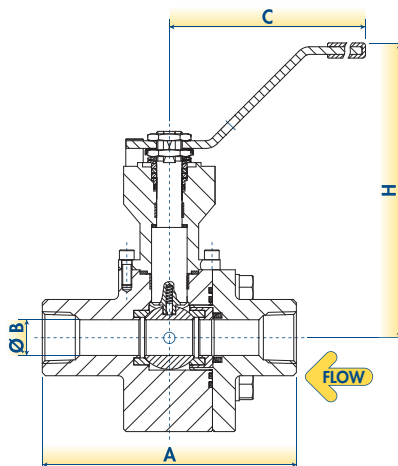

INTEGRAL NIPPLES

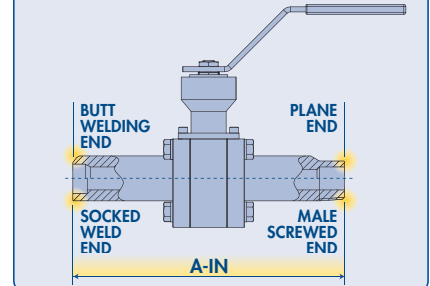

WELDED NIPPLES

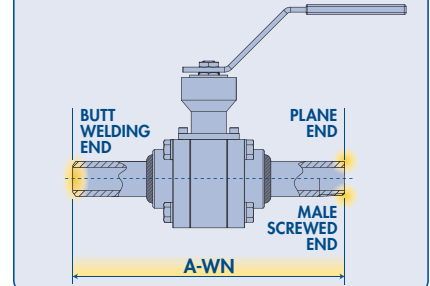

REDUCED BORE FLOATING BALL VALVES

CRYOGENIC CONFIGURATION

THREADED AND WELDING ENDS VALVES

WORKING PRESSURE RATING	SIZE		STANDARD DESIGN TYPE	A		A-IN		A-WN		B		C		H		WEIGHT		FIGURE
	NPS	DN		mm	in	mm	in	mm	in	mm	in	mm	in	mm	in	kg	lb	
ASME 600	3"	80	2	180	7.09	298	11.73	380	14.96	49	1.93	360	14.2	387	15.2	14.5	31.9	6CL-710
ASME 800	1/2"	15	2	100	3.94	236	9.29	300	11.81	11	0.43	160	6.3	323	12.7	2	4.4	HCL 703
	3/4"	20	2	105	4.13	239	9.41	305	12.01	14	0.55	160	6.3	326	12.8	4.3	9.5	HCL 704
	1"	25	2	115	4.53	250	9.84	315	12.40	20	0.79	195	7.7	358	14.1	6.4	14.1	HCL 705
	1-1/4"	32	2	120	4.72	261	10.28	320	12.60	25.4	1.00	195	7.7	361	14.2	7.6	16.8	HCL 706
	1-1/2"	40	2	130	5.12	270	10.63	330	12.99	32	1.26	260	10.2	375	14.8	9.5	20.9	HCL 707
	2"	50	2	150	5.91	279	10.98	350	13.78	38	1.50	260	10.2	380	15.0	12.3	27.1	HCL 708
	3"	80	2	200	7.87	300	11.81	400	15.75	49	1.93	360	14.2	404	15.9	18.0	39.6	HCL-710
ASME 900	1/2"	15	2	100	3.94	236	9.29	300	11.81	11	0.43	160	6.3	323	12.7	2	4.4	90HCL 703
	3/4"	20	2	105	4.13	239	9.41	305	12.01	14	0.55	160	6.3	326	12.8	4.3	9.5	90HCL 704
	1"	25	2	115	4.53	250	9.84	315	12.40	20	0.79	195	7.7	358	14.1	6.4	14.1	90HCL 705
	1-1/4"	32	1	120	4.72	261	10.28	320	12.60	25.4	1.00	195	7.7	361	14.2	7.6	16.8	90HCL 706
	1-1/2"	40	1	130	5.12	270	10.63	330	12.99	32	1.26	260	10.2	375	14.8	9.5	20.9	90HCL 707
	2"	50	1	150	5.91	279	10.98	350	13.78	38	1.50	260	10.2	380	15.0	12.3	27.1	90HCL 708

PRODUCT FEATURES:

- Live Loaded Stem Seal.
- ISO 5211 mounting integrated in the forged body.
- Anti-static Device.
- Blow-out Proof stem.
- Fire-Safe.
- Pressure equalization hole on the ball.

DESIGN TYPE 1

3-PIECE & ENCAPSULATED SEAT

Standard design available with threaded ends. Socked-weld and butt-welding ends are available only with nipple.

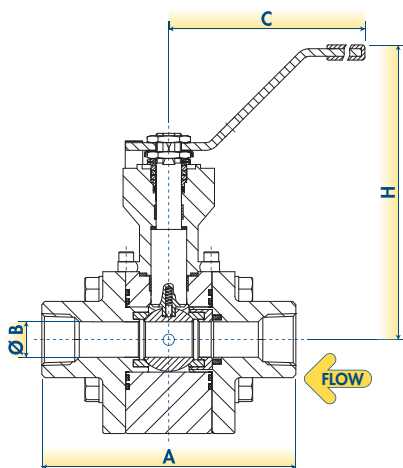

DESIGN TYPE 2

2-PIECE & ENCAPSULATED SEAT

Standard design available with threaded ends. Socked-weld and butt-welding ends are available only with nipple.

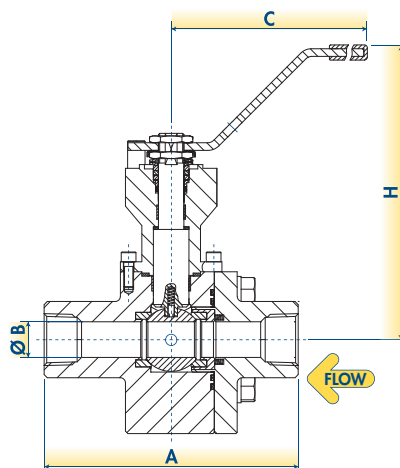

INTEGRAL NIPPLES

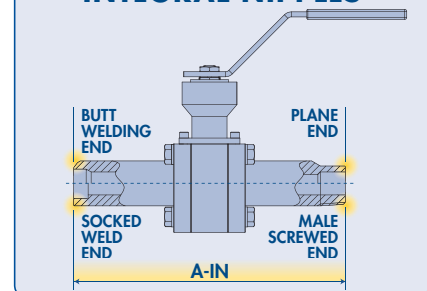

WELDED NIPPLES

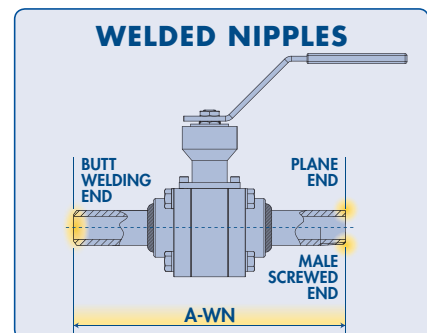

FULL BORE FLOATING BALL VALVES

CRYOGENIC CONFIGURATION

ASME INTEGRAL FLANGED VALVES

WORKING PRESSURE RATING	SIZE		STANDARD DESIGN TYPE	A-RF		A-RJ		B		B1		C		H		WEIGHT		FIGURE
	NPS	DN		mm	in	mm	in	mm	in	mm	in	mm	in	mm	in	kg	lb	
ASME 150	1/2"	15	2	108.5	4.25	N.A.	N.A.	14	0.55	N.A.	N.A.	160	6.3	326	12.8	5	11.0	1C703
	3/4"	20	2	117.5	4.62	N.A.	N.A.	20	0.79	N.A.	N.A.	195	7.7	358	14.1	7.2	15.9	1C704
	1"	25	2	127	5.00	140	5.50	25.4	1.00	N.A.	N.A.	195	7.7	361	14.2	9.1	20.1	1C705
	1-1/4"	32	2	140	5.50	153	6.00	32	1.26	N.A.	N.A.	260	10.2	375	14.8	11.2	24.7	1C706
	1-1/2"	40	2	165	6.50	178	7.00	38	1.50	N.A.	N.A.	260	10.2	380	15.0	13.7	30.2	1C707
	2"	50	2	178	7.00	191	7.50	49	1.93	N.A.	N.A.	360	14.2	387	15.2	20	44.1	1C708
	3"	80	2	203	8.00	216	8.50	76	2.99	N.A.	N.A.	450	17.7	434	17.1	37	81.6	1C710
	4"	100	1	229	9.00	242	9.50	100	3.94	N.A.	N.A.	450	17.7	453	17.8	56	123.5	1C711
ASME 300	1/2"	15	1	140	5.50	151	5.94	14	0.55	N.A.	N.A.	160	6.3	326	12.8	6.5	14.3	3C-703
	3/4"	20	1	152	6.00	165	6.50	20	0.79	N.A.	N.A.	195	7.7	358	14.1	9	19.8	3C-704
	1"	25	1	165	6.50	178	7.00	25.4	1.00	N.A.	N.A.	195	7.7	361	14.2	11.5	25.4	3C-705
	1-1/4"	32	1	178	7.00	191	7.50	32	1.26	N.A.	N.A.	260	10.2	375	14.8	15.5	34.2	3C-706
	1-1/2"	40	1	191	7.50	203	8.00	38	1.50	N.A.	N.A.	260	10.2	380	15.0	19	41.9	3C-707
	2"	50	1	216	8.50	232	9.12	49	1.93	N.A.	N.A.	360	14.2	387	15.2	24.8	54.7	3C-708
	3"	80	1	282	11.12	298	11.74	76	2.99	N.A.	N.A.	450	17.7	434	17.1	47	103.6	3C-710
	4"	100	1	305	12.00	321	12.62	100	3.94	N.A.	N.A.	450	17.7	453	17.8	78	172.0	3C-711
ASME 600	1/2"	15	1	165	6.50	163	6.44	14	0.55	N.A.	N.A.	160	6.3	326	12.8	7.5	16.5	6C-703
	3/4"	20	1	191	7.50	191	7.50	20	0.79	N.A.	N.A.	195	7.7	358	14.1	10	22.0	6C-704
	1"	25	1	216	8.50	216	8.50	25.4	1.00	N.A.	N.A.	195	7.7	361	14.2	12.5	27.6	6C-705
	1-1/4"	32	1	229	9.00	229	9.00	32	1.26	N.A.	N.A.	260	10.2	375	14.8	17	37.5	6C-706
	1-1/2"	40	1	241	9.50	241	9.50	38	1.50	N.A.	N.A.	260	10.2	380	15.0	21.5	47.4	6C-707
	2"	50	1	292	11.50	295	11.62	49	1.93	N.A.	N.A.	360	14.2	387	15.2	28	61.7	6C-708
	3"	80	1	356	14.00	359	14.12	76	2.99	N.A.	N.A.	450	17.7	434	17.1	53	116.8	6C-710
	ASME 1500	1/2"	15	1	216	8.50	216	8.50	11.1	0.44	N.A.	N.A.	195	7.7	350	13.8	10.1	22.3
3/4"		20	1	229	9.00	229	9.00	15.5	0.61	N.A.	N.A.	195	7.7	357	14.1	14.5	32.0	15HC 704
1"		25	1	254	10.00	254	10.00	21	0.83	N.A.	N.A.	260	10.2	371	14.6	22	48.5	15HC 705
1-1/4"		32	1	279	11.00	279	11.00	34	1.34	N.A.	N.A.	360	14.2	404	15.9	30.5	67.2	15HC 706
1-1/2"		40	1	305	12.00	305	12.00	34	1.34	N.A.	N.A.	360	14.2	404	15.9	34.5	76.1	15HC 707
2"		50	1	368	14.50	371	14.60	43	1.69	N.A.	N.A.	360	14.2	412	16.2	44	97.0	15HC 708
ASME 2500	1/2"	15	1	264	10.38	264	10.38	11.1	0.44	N.A.	N.A.	195	7.7	350	13.8	13	28.7	25HC 703
	3/4"	20	1	273	10.75	273	10.75	15.5	0.61	N.A.	N.A.	195	7.7	357	14.1	18	39.7	25HC 704
	1"	25	1	308	12.12	308	12.12	21	0.83	N.A.	N.A.	260	10.2	371	14.6	24.5	54.0	25HC 705

PRODUCT FEATURES:

- Live Loaded Stem Seal. • ISO 5211 mounting integrated in the forged body. • Anti-static Device. • Blow-out Proof stem. • Fire-Safe. • Pressure equalization hole on the ball.

DESIGN TYPE 1

3-PIECE & ENCAPSULATED SEAT

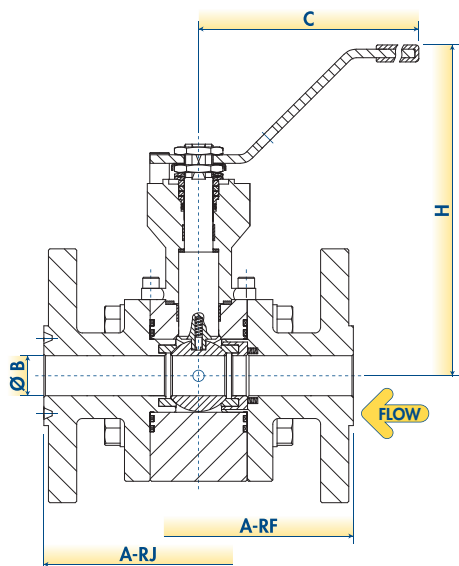

DESIGN TYPE 2

2-PIECE & ENCAPSULATED SEAT

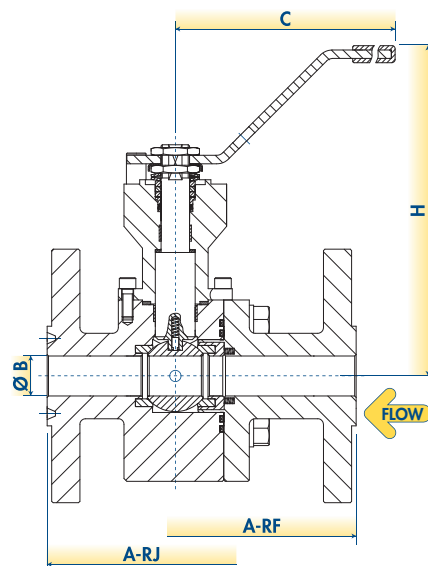

REDUCED BORE FLOATING BALL VALVES

CRYOGENIC CONFIGURATION

ASME INTEGRAL FLANGED VALVES

WORKING PRESSURE RATING	SIZE		STANDARD DESIGN TYPE	A-RF		A-RJ		B		B1		C		H		WEIGHT		FIGURE
	NPS	DN		mm	in	mm	in	mm	in	mm	in	mm	in	mm	in	kg	lb	
ASME 150	1/2"	15	2	108.5	4.25	N.A.	N.A.	11	0.43	14	0.55	160	6.3	323	12.7	5.7	12.6	1CL 703
	3/4"	20	2	117.5	4.62	N.A.	N.A.	14	0.55	20	0.79	160	6.3	326	12.8	7.3	16.1	1CL 704
	1"	25	2	127	5.00	140	5.50	20	0.79	25.4	1.00	195	7.7	358	14.1	9	19.8	1CL 705
	1-1/4"	32	2	140	5.50	153	6.00	25.4	1.00	32	1.26	195	7.7	361	14.2	11.3	24.9	1CL 706
	1-1/2"	40	2	165	6.50	178	7.00	32	1.26	38	1.50	260	10.2	375	14.8	14.3	31.5	1CL 707
	2"	50	2	178	7.00	191	7.50	38	1.50	49	1.93	260	10.2	380	15.0	17.6	38.8	1CL 708
	3"	80	1	203	8.00	216	8.50	49	1.93	76	2.99	360	14.2	387	15.2	30.2	66.6	1CL 710
	4"	100	1	229	9.00	242	9.50	76	2.99	100	3.94	450	17.7	434	17.1	39.3	86.6	1CL 711
ASME 300	1/2"	15	1	140	5.50	151	5.94	11	0.43	14	0.55	160	6.3	323	12.7	6	13.2	3CL 703
	3/4"	20	1	152	6.00	165	6.50	14	0.55	20	0.79	160	6.3	326	12.8	8	17.6	3CL 704
	1"	25	1	165	6.50	178	7.00	20	0.79	25.4	1.00	195	7.7	358	14.1	10.5	23.1	3CL 705
	1-1/4"	32	1	178	7.00	191	7.50	25.4	1.00	32	1.26	195	7.7	361	14.2	13.2	29.1	3CL 706
	1-1/2"	40	1	191	7.50	203	8.00	32	1.26	38	1.50	260	10.2	375	14.8	17.1	37.7	3CL 707
	2"	50	1	216	8.50	232	9.12	38	1.50	49	1.93	260	10.2	380	15.0	20.8	45.9	3CL 708
	3"	80	1	282	11.12	298	11.74	49	1.93	76	2.99	360	14.2	387	15.2	35	77.2	3CL 710
	4"	100	1	305	12.00	321	12.62	76	2.99	100	3.94	450	17.7	434	17.1	51	112.4	3CL 711
ASME 600	1/2"	15	1	165	6.50	163	6.44	11	0.43	14	0.55	160	6.3	323	12.7	6.8	15.0	6CL 703
	3/4"	20	1	191	7.50	191	7.50	14	0.55	20	0.79	160	6.3	326	12.8	9	19.8	6CL 704
	1"	25	1	216	8.50	216	8.50	20	0.79	25.4	1.00	195	7.7	358	14.1	11.5	25.4	6CL 705
	1-1/4"	32	1	229	9.00	229	9.00	25.4	1.00	32	1.26	195	7.7	361	14.2	14	30.9	6CL 706
	1-1/2"	40	1	241	9.50	241	9.50	32	1.26	38	1.50	260	10.2	375	14.8	18.6	41.0	6CL 707
	2"	50	1	292	11.50	295	11.62	38	1.50	49	1.93	260	10.2	380	15.0	23.2	51.1	6CL 708
	3"	80	1	356	14.00	359	14.12	49	1.93	76	2.99	360	14.2	387	15.2	39	86.0	6CL 710

PRODUCT FEATURES:

- Live Loaded Stem Seal. • ISO 5211 mounting integrated in the forged body. • Anti-static Device. • Blow-out Proof stem. • Fire-Safe. • Pressure equalization hole on the ball.

DESIGN TYPE 1

3-PIECE & ENCAPSULATED SEAT

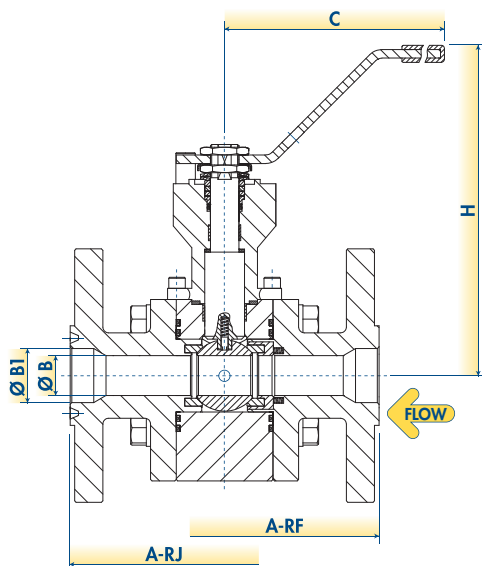

DESIGN TYPE 2

2-PIECE & ENCAPSULATED SEAT

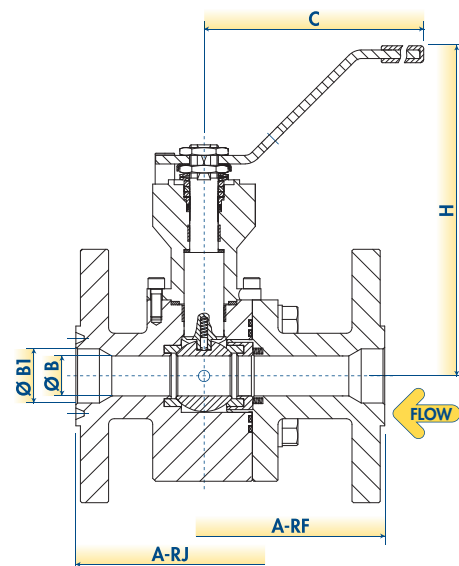

FULL BORE FLOATING BALL VALVES

HIGH TEMPERATURE & EROSION SERVICE CONFIGURATION

THREADED AND WELDING ENDS VALVES

WORKING PRESSURE RATING	SIZE		STANDARD DESIGN TYPE	A		A-IN		A-WN		B		C		H		WEIGHT		FIGURE
	NPS	DN		mm	in	mm	in	mm	in	mm	in	mm	in	mm	in	kg	lb	
ASME 800	1/2"	15	1	105	4.13	264	10.39	305	12.01	14	0.55	195	7.7	213	8.4	5.3	11.7	H 703
	3/4"	20	1	115	4.53	265	10.43	315	12.40	20	0.79	195	7.7	215	8.5	7	15.4	H 704
	1"	25	1	130	5.12	281	11.06	330	12.99	25.4	1.00	195	7.7	220	8.7	8.1	17.9	H 705
	1-1/2"	40	2	160	6.30	299	11.77	360	14.17	38	1.50	250	9.8	290	11.4	27	59.5	H 707

PRODUCT FEATURES:

- Live Loaded Stem Seal.
- Phosphate coated carbon steel valve body/closure.
- ISO 5211 mounting integrated in the forged body.
- Anti-static Device.
- Blow-out Proof stem.
- Fire-Safe.
- Cavity Pressure relief seat design.

REDUCED BORE FLOATING BALL VALVES

HIGH TEMPERATURE & EROSION SERVICE CONFIGURATION

THREADED AND WELDING ENDS VALVES

WORKING PRESSURE RATING	SIZE		STANDARD DESIGN TYPE	A		A-IN		A-WN		B		C		H		WEIGHT		FIGURE
	NPS	DN		mm	in	mm	in	mm	in	mm	in	mm	in	mm	in	kg	lb	
ASME 800	3/4"	20	1	105	4.13	255	10.04	305	12.01	14	0.55	195	7.7	213	8.4	5.3	11.7	H 703
	1"	25	1	115	4.53	266	10.47	315	12.40	20	0.79	195	7.7	215	8.5	7	15.4	H 704
	1-1/2"	40	1	150	5.91	289	11.38	350	13.78	32	1.26	250	9.8	230	9.1	14.7	32.4	H 705

PRODUCT FEATURES:

- Live Loaded Stem Seal.
- Phosphate coated carbon steel valve body/closure.
- ISO 5211 mounting integrated in the forged body.
- Anti-static Device.
- Blow-out Proof stem.
- Fire-Safe.
- Cavity Pressure relief seat design.

DESIGN TYPE 1
2-PIECE
LEVER OPERATED

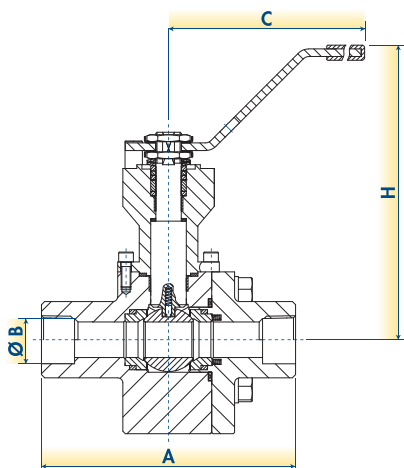

DESIGN TYPE 2
2-PIECE
GEAR OPERATED

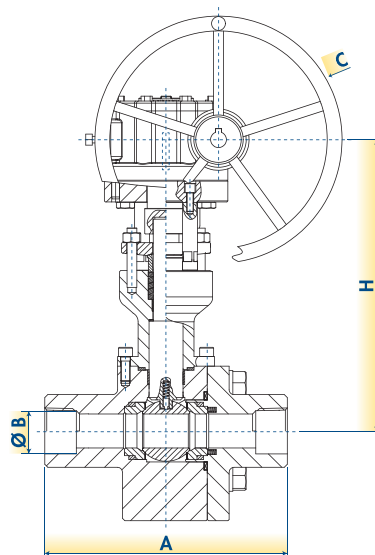

INTEGRAL NIPPLES

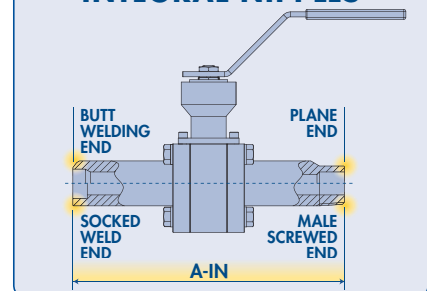

WELDED NIPPLES

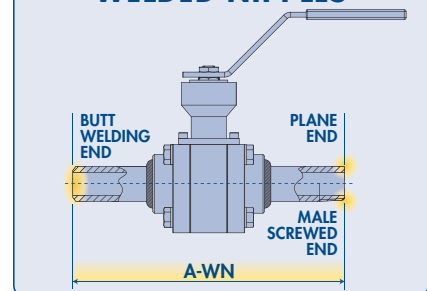

FULL BORE FLOATING BALL VALVES

HIGH TEMPERATURE & EROSION SERVICE CONFIGURATION

ASME INTEGRAL FLANGED VALVES

WORKING PRESSURE RATING	SIZE		STANDARD DESIGN TYPE	A-RF		A-RJ		B		B1		C		H		WEIGHT		FIGURE
	NPS	DN		mm	in	mm	in	mm	in	mm	in	mm	in	mm	in	kg	lb	
ASME 150 (SEE NOTE 1)	1/2"	15	1	140 ⁽¹⁾	5.50	N.A.	N.A.	14	0.55	N.A.	N.A.	195	7.7	213	8.4	5.5	12.1	1-703
	3/4"	20	1	152 ⁽¹⁾	6.00	N.A.	N.A.	20	0.79	N.A.	N.A.	195	7.7	215	8.5	6.3	13.9	1-704
	1"	25	1	165 ⁽¹⁾	6.50	178 ⁽¹⁾	7.00	25.4	1.00	N.A.	N.A.	195	7.7	220	8.7	8	17.6	1-705
	1-1/4"	32	2	178 ⁽¹⁾	7.00	191 ⁽¹⁾	7.50	32	1.26	N.A.	N.A.	250	9.8	290	11.3	26	57.3	1-706
	1-1/2"	40	2	191 ⁽¹⁾	7.50	203 ⁽¹⁾	8.00	38	1.50	N.A.	N.A.	250	9.8	290	11.3	26.5	58.4	1-707
	2"	50	2	216 ⁽¹⁾	8.50	232 ⁽¹⁾	9.12	49	1.93	N.A.	N.A.	250	9.8	300	11.6	31.5	69.4	1-708
ASME 300	1/2"	15	1	140	5.50	151	5.94	14	0.55	N.A.	N.A.	195	7.7	213	8.4	6	13.2	3-703
	3/4"	20	1	152	6.00	165	6.50	20	0.79	N.A.	N.A.	195	7.7	215	8.5	7	15.4	3-704
	1"	25	1	165	6.50	178	7.00	25.4	1.00	N.A.	N.A.	195	7.7	220	8.7	9	19.8	3-705
	1-1/4"	32	2	178	7.00	191	7.50	32	1.26	N.A.	N.A.	250	9.8	290	11.3	28.5	62.8	3-706
	1-1/2"	40	2	191	7.50	203	8.00	38	1.50	N.A.	N.A.	250	9.8	290	11.3	29.5	65.0	3-707
	2"	50	2	216	8.50	232	9.12	49	1.93	N.A.	N.A.	250	9.8	300	11.6	33.5	73.9	3-708
ASME 600	1/2"	15	1	165	6.50	163	6.44	14	0.55	N.A.	N.A.	195	7.7	213	8.4	6.3	13.9	6-703
	3/4"	20	1	191	7.50	191	7.50	20	0.79	N.A.	N.A.	195	7.7	215	8.5	7.6	16.7	6-704
	1"	25	1	216	8.50	216	8.50	25.4	1.00	N.A.	N.A.	195	7.7	220	8.7	10	22.0	6-705
	1-1/4"	32	2	229	9.00	229	9.00	32	1.26	N.A.	N.A.	250	9.8	290	11.3	31	68.3	6-706
	1-1/2"	40	2	241	9.50	241	9.50	38	1.50	N.A.	N.A.	250	9.8	290	11.3	32	70.5	6-707

PRODUCT FEATURES:

- Live Loaded Stem Seal. • Phosphate coated carbon steel valve body/closure. • ISO 5211 mounting integrated in the forged body. • Anti-static Device. • Blow-out Proof stem. • Fire-Safe. • Cavity Pressure relief seat design.

NOTE 1: Face-to-Face acc.to ASME B16.10 related to class 300.

DESIGN TYPE 1

2-PIECE - LEVER OPERATED

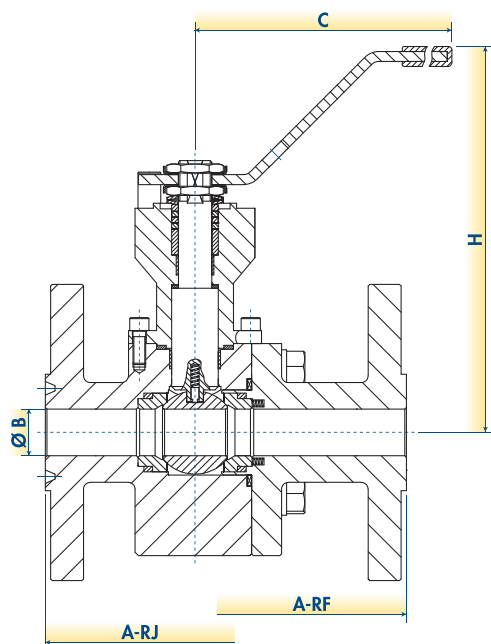

DESIGN TYPE 2

2-PIECE - GEAR OPERATED

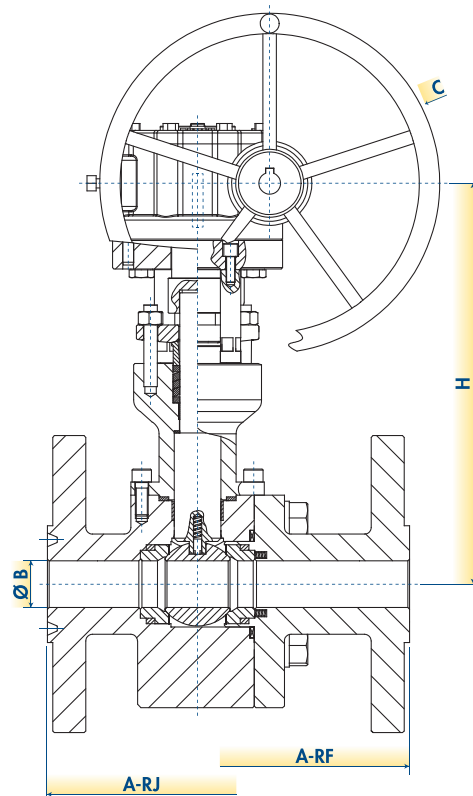

REDUCED BORE FLOATING BALL VALVES HIGH TEMPERATURE & EROSION SERVICE CONFIGURATION ASME INTEGRAL FLANGED VALVES

WORKING PRESSURE RATING	SIZE		STANDARD DESIGN TYPE	A-RF		A-RJ		B		B1		C		H		WEIGHT		FIGURE
	NPS	DN		mm	in	mm	in	mm	in	mm	in	mm	in	mm	in	kg	lb	
ASME 150 (SEE NOTE 1)	3/4"	20	1	152 ⁽¹⁾	6.00	N.A.	N.A.	14	0.55	20	0.79	195	7.7	213	8.4	6	13.2	L1 704
	1"	25	1	165 ⁽¹⁾	6.50	178 ⁽¹⁾	7.00	20	0.79	25.4	1.00	195	7.7	215	8.5	7	15.4	L1 705
	1-1/2"	40	2	191 ⁽¹⁾	7.50	203 ⁽¹⁾	8.00	32	1.26	38	1.50	250	9.8	290	11.4	26	57.3	L1 707
	2"	50	2	216 ⁽¹⁾	8.50	232 ⁽¹⁾	9.12	38	1.50	49	1.93	250	9.8	290	11.4	30	66.1	L1 708
	3"	80	2	282 ⁽¹⁾	11.12	298 ⁽¹⁾	11.74	49	1.93	76	2.99	250	9.8	300	11.8	40	88.2	L1 701
ASME 300	3/4"	20	1	152	6.00	165	7.00	14	0.55	20	0.79	195	7.7	213	8.4	7	15.4	L3 704
	1"	25	1	165	6.50	178	8.00	20	0.79	25.4	1.00	195	7.7	215	8.5	8	17.6	L3 705
	1-1/2"	40	2	191	7.50	203	9.12	32	1.26	38	1.50	250	7.7	290	11.4	27	59.5	L3 707
	2"	50	2	216	8.50	232	9.13	38	1.50	49	1.93	250	9.8	290	11.4	31	68.3	L3 708
	3"	80	2	282	11.12	298	11.74	49	1.93	76	2.99	250	9.8	300	11.8	45	99.2	L3 710
ASME 600	3/4"	20	1	191	7.50	191	7.50	14	0.55	20	0.79	195	7.7	213	8.4	7.3	16.1	L6 704
	1"	25	1	216	8.50	216	8.50	20	0.79	25.4	1.00	195	7.7	215	8.5	8.6	18.9	L6 705
	1-1/2"	40	2	241	9.50	241	9.50	32	1.26	38	1.50	250	9.8	290	11.4	28	61.7	L6 707
	2"	50	2	292	11.50	295	11.62	38	1.50	49	1.93	250	9.8	290	11.4	39	86.0	L6 708

PRODUCT FEATURES:

- Live Loaded Stem Seal.
- Phosphate coated carbon steel valve body/closure.
- ISO 5211 mounting integrated in the forged body.
- Anti-static Device.
- Blow-out Proof stem.
- Fire-Safe.
- Cavity Pressure relief seat design.

NOTE 1: Face-to-Face acc.to ASME B16.10 related to class 300.

DESIGN TYPE 1

2-PIECE - LEVER OPERATED

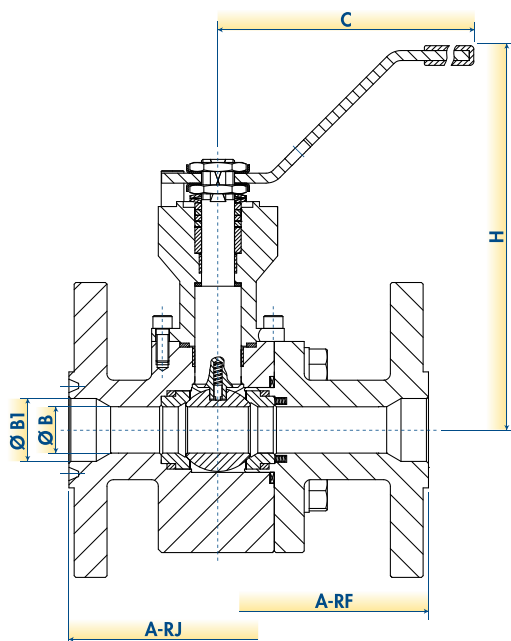

DESIGN TYPE 2

2-PIECE - GEAR OPERATED

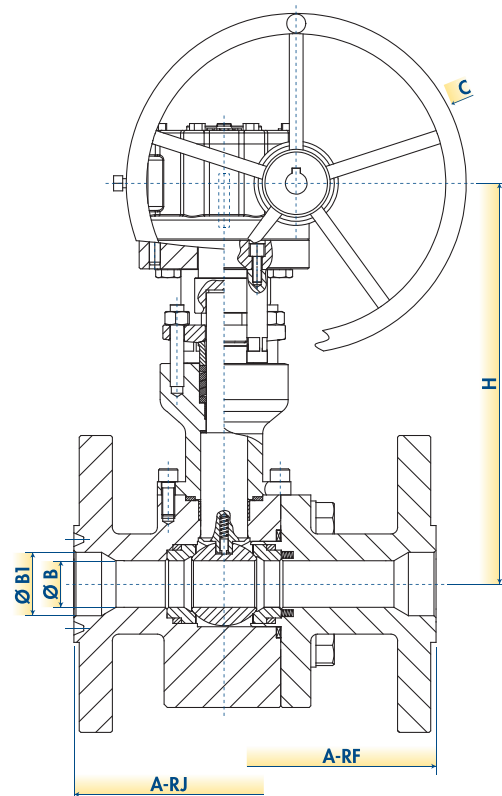

VALVE SEAT & GASKET MATERIAL SELECTION GUIDE

Choosing the right seat material is the most important decision in ball valve selection. Use the Pressure/Temperature rating chart for the most common seat materials and ask us in case of special material or applications.

HOW TO USE THIS CHART

- Please note that the ratings are referred to the valve seats. Do not use these ratings for the valve class selections.
- All rating charts have been provided for non-shock fluid service.
- The choice of the seat material is limited by characteristics of the service fluid, working pressures, fluid velocity, and operational frequency of the valve. Choosing the right seat material is the most important decision in ball valve selection. Use the pressure/temperature rating charts for the most common seat materials and ask us in case of special material or applications.
- The BFE SEAL CODE (3 digits) is designed to cover essential features of BFE seats and gasket material, the code is marked on the valve name plate in order to easy allow customers to identify the internal soft material.

DIGIT-1 – INSERT SEAT MATERIAL
 DIGIT-2 – EMERGENCY BODY SEAL
 DIGIT-3 – FIRST BODY SEAL

Example: SEAL CODE "RGR":
 INSERT SEAT MATERIAL = RPTFE CARBO-GRAPHITE
 EMERGENCY BODY SEAL = GRAPHITE
 FIRST BODY SEAL = RPTFE CARBO-GRAPHITE

PLANE SEAT PRESSURE/TEMPERATURE RATING (SWING-OUT VALVES)

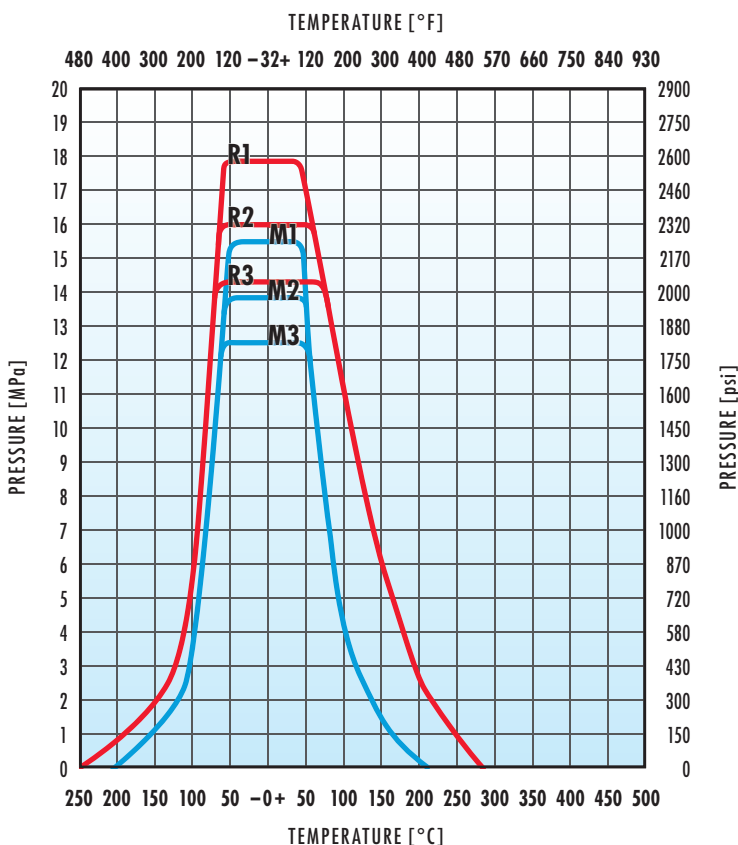

SEAT RATING CURVE ID	VALVE NPS FULL BORE	VALVE NPS REDUCED BORE
R1	3/8" & 1/2"	1/2" & 3/4"
R2	3/4" & 1"	1" & 1-1/4"
R3	1-1/4" & 1-1/2"	1-1/2" & 2"
M1	3/8" & 1/2"	1/2" & 3/4"
M2	3/4" & 1"	1" & 1-1/4"
M3	1-1/4" & 1-1/2"	1-1/2" & 2"

— R - RPTFE CARBON-GRAPHITE
— M - VIRGIN PTFE

PLEASE NOTE THAT THE FOLLOWING RATINGS ARE REFERRED TO THE VALVE SEATS. DO NOT USE THIS RATINGS FOR THE VALVE CLASS SELECTION.

ENCAPSULATED SEAT PRESSURE/TEMPERATURE RATING

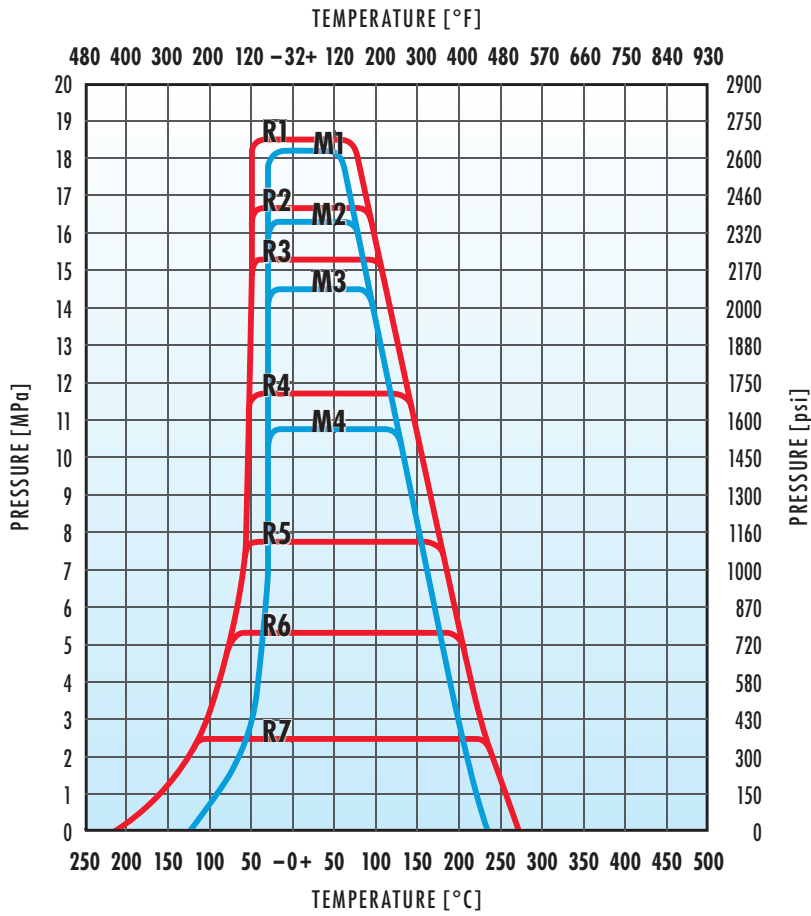

SEAT RATING CURVE ID	VALVE NPS FULL BORE	VALVE NPS REDUCED BORE
R1	3/8" & 1/2"	1/2" & 3/4"
R2	3/4" & 1"	1" & 1-1/4"
R3	1-1/4" & 1-1/2"	1-1/2" & 2"
R4	2"	3"
R5	3"	4"
R6	4"	6"
R7	6"	8"
M1	3/8" & 1/2"	1/2" & 3/4"
M2	3/4" & 1"	1" & 1-1/4"
M3	1-1/4" & 1-1/2"	1-1/2" & 2"
M4	2"	3"

PLEASE NOTE THAT THE FOLLOWING RATINGS ARE REFERRED TO THE VALVE SEATS. DO NOT USE THIS RATINGS FOR THE VALVE CLASS SELECTION.

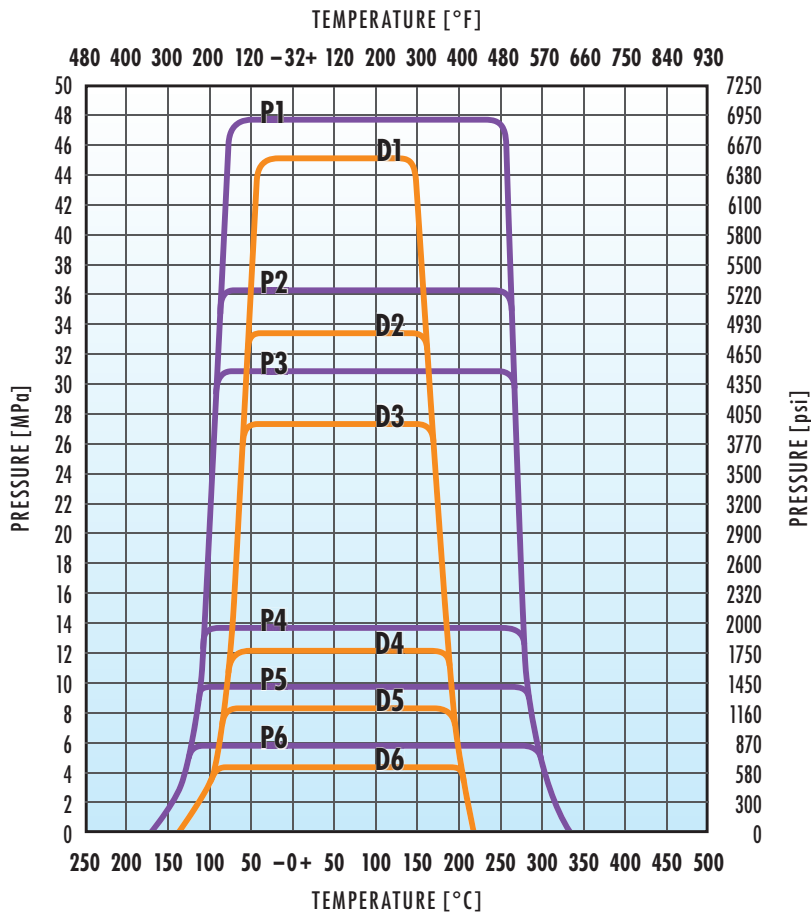

SEAT RATING CURVE ID	VALVE NPS FULL BORE	VALVE NPS REDUCED BORE
P1	3/8" & 1/2" 3/4" & 1"	1/2" & 3/4" 1" & 1-1/4"
P2	1-1/4" & 1-1/2"	1-1/2" & 2"
P3	2"	3"
P4	3"	4"
P5	4"	6"
P6	6"	8"
D1	3/8" & 1/2" 3/4" & 1"	1/2" & 3/4" 1" & 1-1/4"
D2	1-1/4" & 1-1/2"	1-1/2" & 2"
D3	2"	3"
D4	3"	4"
D5	4"	6"
D6	6"	8"

The following table shows the most used materials, their characteristics, application (seat or gasket) and the BFE ID.

SEAL MATERIAL	MATERIALS CHARACTERISTICS	BFE SYMBOL	AVAILABLE MATERIAL FOR SEAT	AVAILABLE MATERIAL FOR GASKET
			BFE SEAL CODE DIGIT 1	BFE SEAL CODE DIGIT 2/3
VIRGIN PTFE	Polytetrafluoroethylene is a fluorocarbon-based polymer. This seating material has excellent chemical resistance and low coefficient of friction. PTFE is non-contaminating and accepted by FDA for use in food services. Not recommended for liquid alkalis and fluorine.	M	YES	YES
RPTFE 25% CARBO-GRAPHITE	PTFE's mechanical properties are enhanced by adding percentage of filler material to provide improved strength, stability and wear resistance.	R	YES	YES
"RPTFE 25%GLASS"	25% Glass Filled PTFE (Reinforced Polytetrafluoroethylene) is similar to RPTFE- CARBO-GRAPHITE but with even better resistance to wear and deformation under load. Strongly suggested for Sea-Water Service.	A	YES	YES
RPTFE 60% BRONZE	This material exhibits a unique combination of heat resistance and low friction together with outstanding chemical and good electrical properties. No moisture absorption, high arc resistance, and is self lubricating with a low coefficient of friction.	B	YES	NO
PEEK	Polyetheretherketone high temperature semi rigid elastomer. Best suited for high pressure and temperature service. Also offers very good corrosion resistance.	P	YES	NO
DEVLON-V	Devlon-V (special Nylon produced by Devol Engineering Ltd) offers very good performances regarding the maximum allowable pressure and excellent elasticity.	D	YES	NO
KEL-F	PCTFE (Polychlorotrifluoroethylene) is a fluorocarbon based polymer. It offers a unique combination of physical and mechanical properties non-flammability, chemical resistance, and near zero moisture absorption. It is suitable for cryogenic applications.	K	YES	NO
UHMWP	Ultra-High Molecular Weight Polyethylene. Ideal for use in lowlevel radiation service. This seat also meets the requirements of the tobacco industry where TFE is prohibited and it offers an excellent resistance to abrasive media.	U	YES	YES
VESPEL	Vespel is manufactured by DuPont using high performance polyimide resin. Performs well in a variety of chemical environments and a variety of industrial fluids (fuels, oils, lubricants) at elevated temperatures. Temperature range can operate continuously from cryogenic to high temperature. Performs well in radio-active environments, even at relatively high dosage rates of exposure levels.	V	YES	NO
VITON	Standard material for O-RING.	V	NO	YES
SILICON	Silicon is a semi-organic elastomer with outstanding resistance to low temperatures. Silicon also has good resistance to compression set. Low physical strength and abrasion resistance combined with high friction limit silicone to low pressure applications. Silicone is used primarily for dry heat static seals.	S	NO	YES
SPRING ENERGIZED TFE BASED	"Spring energised plastic seals (Lip-Seal) from PTFE and PTFE compounds, with standard and special profiles for temperature from -196°C to +260°C, pressure range from high pressure to vacuum. Spring standard material ASTM F1058 R30003. Alternative spring materials are available and other elastomer compounds are available to suit special applications/media."	E	NO	YES
TUNGSTEN CARBIDE COATING	For liquid or gas services with high presence of solids or in any case where extreme hardness and wear resistance is required. Tungsten carbide itself is practically inert and extremely strong. Any attack is usually on the binder. Not suitable when small presence of caustic soda is expected.	W	YES	N.A.
CHROME CARBIDE COATING	For liquid or gas services with small presence of solids. Not suitable when small presence of caustic soda is expected.	C	YES	N.A.
GRAPHITE	Hard carbon with excellent heat resistance. Not suitable as seat material when presence of oxidized service is expected.	G	YES	YES
OTHER	For other materials please ask to BFE.	-	-	-

CRYOGENIC CONFIGURATION

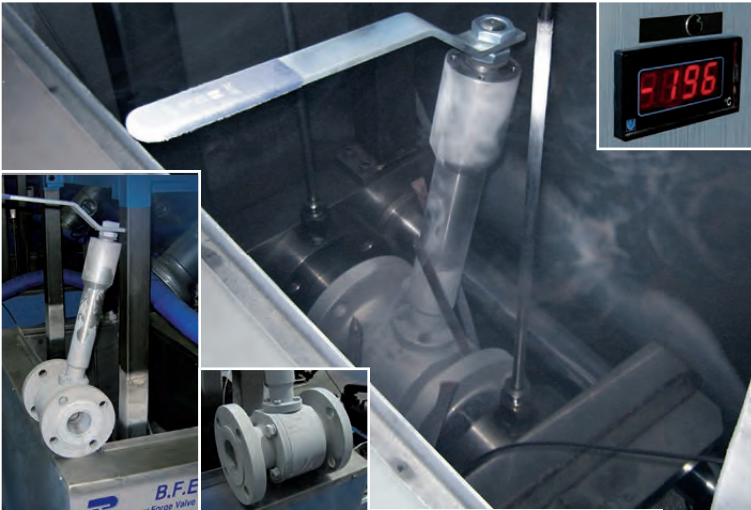

BFE floating ball valves designated for use in cryogenic temperatures to minus 196°C (320°F) offer superior service life in tough and demanding applications.

The design incorporates a vent hole drilled on the upstream side of the ball, eliminating the possibility of trapping liquid or gas in the cavity and thereby preventing dangerous overpressure due to thermal expansion.

The bonnet extension keeps heat transfer down, the packing frost free and the operational torque low.

Selection of materials of construction is optimized for the intended service. Extended bonnets are provided to ensure zero leakage.

METAL SEATED CONFIGURATION

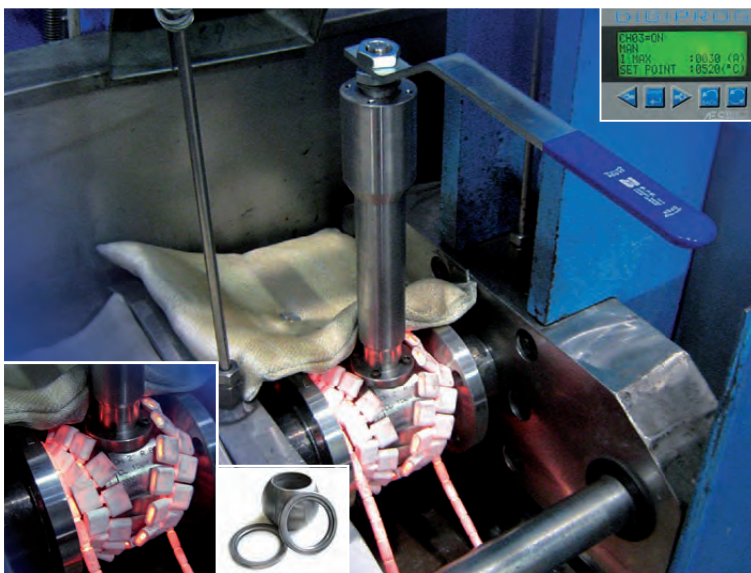

BFE metal seated floating ball valves are designed for high temperature applications and for abrasive services:

- HIGH TEMPERATURE:** BFE floating ball valves designated for high temperature operation offer superior service life for any kind of fluid compatible with graphite. BFE Metal to Metal sealed ball valves employ a special spring loaded seat design, which would absorb the heat expansion of valve components, so that the valve would not get stuck due the high temperature.
- ABRASIVE SERVICE:** The valve is highly resistant to erosion, very effective in the handling of fluids containing abrasives and any dirty media and maintenance free. The valve is provided with Tungsten Carbide coated metal seats to avoid the erosion of soft seats. Soft seat must not be used for abrasive service.

OTHER SPECIAL SERVICES

SERVICE	DESCRIPTION & VALVE FEATURES
OXYGEN GAS	BFE floating ball valves designated for Oxygen Service are prepared and cleaned to standards required for the safe operation of Oxygen Service equipment and product purity. Acetal Resign (Delrin) seats and Nylatron seals must not be used in oxygen service.
VACUUM	BFE floating ball valves can be used with standard design in "Medium Vacuum" range (up to 0.001 Torr). Specially prepared and tested valves can be used through the "High Vacuum" range. Valves with reinforced TFE, carbon-graphite or metal seats are not recommended for vacuum service.
CHLORINE	BFE floating ball valves designated for Chlorine Service are in stainless steel material (Grade 304 or 316) or other alloys such as Monel or Hastelloy C. Reinforced PTFE can be used for the chlorine service. Due the high coefficient of expansion the ball vent hole is required. The are prepared and cleaned to standards required.
ALIMENTARY	The BFE special "cavity filled" design (standard design for alimentary service valves) offer the best way to maintain the body cavity clean and empty from impurities. BFE floating ball valves designated for alimentary files Service are also prepared and cleaned to standards required.
SLURRY & MUD	The BFE special "cavity filled" design (standard design for slurry service valves) offer the best way to maintain the body cavity empty from slurry and safe from phase transition to the solid state (immobilizing the valve).
RUBBER POLYMERS	The BFE special "cavity filled" design (standard design for polymers service valves) offer the best way to maintain the body cavity empty from fluid and safe from possible polymerization in place (immobilizing the valve).
HYDROGEN PEROXIDE	Ball Valve are recommended for hydrogen peroxide service. The valve is nitrogen leak tested and prepared and cleaned to standards required. The ball vent hole is required.

■ GENERAL SALE CONDITIONS

QUOTATION VALIDITY

Unless otherwise agreed, quotations are valid for four weeks from date of issue.
The delivery terms are always "ex-works" unless otherwise stated.
Prices and sale conditions can be changed without any previous notice.

ORDERS ACCEPTANCE

Orders are considered accepted at our general sale conditions clearly mentioned on order acknowledgment.

GOODS DELIVERY

The Company does not accept any responsibility for delays in delivery which are always intended as indicative and not binding. Transport risks are at receiver's charge also in case of CIF delivery.

GUARANTEE

The Company warrants all its products, from material and/or manufacturing defects, to be used as recommended by standards, and in accordance with approved piping practice and technique, for a period of one year from shipping date, unless otherwise agreed.
The Company liability covers eventual "free of charge" replacements for defective parts or products, providing it has not failed in the observance of above mentioned conditions and in use in compliance with standards, and, anyway, after return of defective goods. Any other liability, neither objective nor subjective will be accepted.

CLAIMS AND ORDER CANCELLATIONS

Claims will be considered only if made within 10 days from goods receipt.
Partial or complete cancellations of order can be accepted only upon previous agreement or by written consent and, however, not later than 15 days from order date.
Any controversy will be handled by the Court of Milan.



Dimensions on the catalogue are indicative.
B.F.E. S.r.l. reserves the right to make all necessary changes without notice.

Printed in Italy 2th edition. Revision 01 2015/02/16



B.F.E. S.r.l. - Via Tonale, 70/A - 24061 Albano S. Alessandro (BG) Italy - Phone: 035.584111 - Fax: 035.583022 - Mail: sales@bfe.it
www.bfe.it

BONNEY FORGE



BONNEY FORGE
+001.814.542.2545
www.bonneyforge.com



+001.713.695.3633 - +001.713.695.3528 f
www.wfi-intl.com

RPC Valve

www.rpc-valve.com