

Forged Gate, Globe and Check Valves

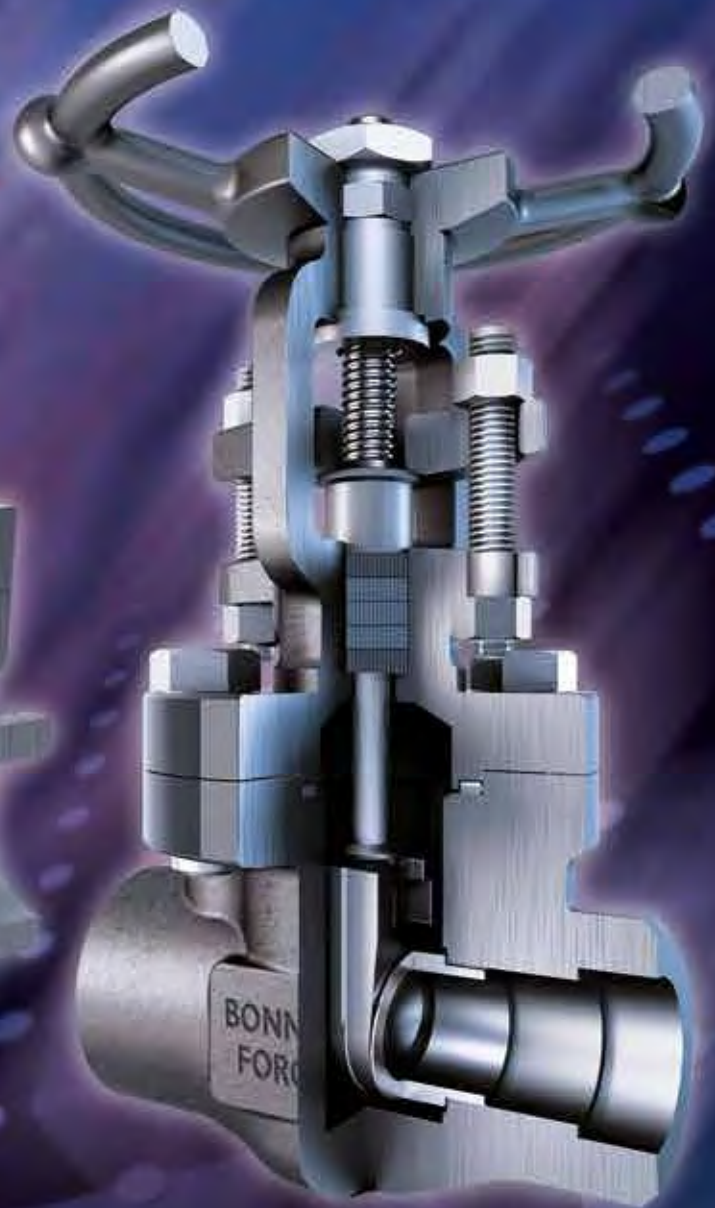

B.F.E. s.r.l.

BONNEY FORGE

TABLE OF CONTENTS



B.F.E. S.r.l.

BONNEY FORGE



RP&C Valve

- A-1 BFE AVAILABLE CATALOGUES
- A-2 THE COMPANY BEHIND THE BRAND
- A-3 COMPANY BACKGROUND
- A-4 TAKING QUALITY TO THE NEXT LEVEL
- A-5 CONFIDENCE IN STEEL FORGING
- A-6 HIGH-END ENGINEERING & MFG

SECTION A



GATE VALVES

B-1 B-18

SECTION B



"T"-PATTERN GLOBE VALVES

C-1 C-16

SECTION C

SECTION D

"Y"-PATTERN
GLOBE VALVES

D-1 D-16



SECTION E

SWING CHECK
VALVES

E-1 E-8



SECTION F

PISTON & BALL
CHECK VALVES

F-1 F-8



SECTION G

ALTERNATIVE
DESIGN
SOLUTIONS

G-1 G-2

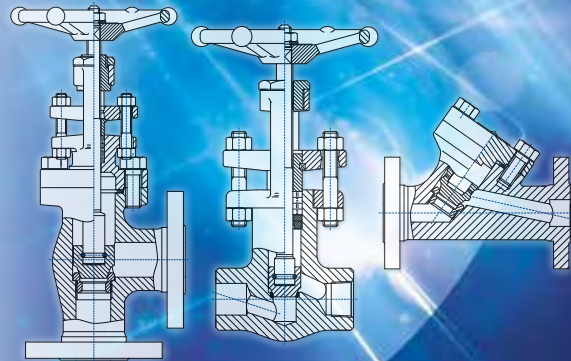

BFE AVAILABLE CATALOGUES

BFE - BONNEY FORGE: VALVE PRODUCTS FOR EVERY INDUSTRY INFRASTRUCTURE

BFE is proud to offer the widest variety of high-quality products and unmatched services. Search our catalogs, search for a product, or contact us for help with your order.



Forged Valves

Forged Pressure Seal Valves

API 6A Valves



Cast Steel Valves

Trunnion Mounted Ball Valves



Forged Floating Ball Valves

Double Block & Bleed Valves

THE COMPANY BEHIND THE BRAND

BFE: EXPERIENCE AND EXPERTISE AT YOUR SERVICE

More than 50 years of experience, expertise and know how strengthen BFE's leadership in the production and commercialization of valves for oil and gas, mining industry, petrochemical, power generation and utilities. This solid and dynamic business strategy allows BFE to identify and provide solutions to meet specific needs, and aims to achieve complete customer satisfaction which today turns out to be of great value.

BONNEY FORGE: THE NAME YOU TRUST FOR FORGED STEEL VALVES

Bonney Forge's forged steel valves and piping components have led the way for over eighty years in state-of-the-art design and dependable performance. It is qualities like these, combined with a customer-driven culture, that maintains Bonney Forge's leadership position within the industry for exceeding customer expectations. Our goal is to make Bonney Forge your number one world-wide choice for forged valves.

OUR MISSION

To be, today and in the future, the recognized leader in our industry, marketing and manufacturing forged steel valves, cast steel valves, forged fittings, branch connections and other related products to satisfy our customer's expectations.

To be cost effective through Total Quality performance of these operations, and thus provide the resources required to support our commitment to improve our products, processes and customer service.

To be a law abiding corporate citizen respecting the rights of individuals, contributing to the needs of the community and conserving the state of the environment.

OUR CREED

- Continuously improving quality, processes and customer service.
- Eliminating delays, errors and defects in materials and workmanship.
- Providing customers with access to statistical evidence that quality is incorporated in our products and production processes.
- Requiring suppliers to provide statistical evidence of quality in products and process capabilities.
- Sharing with the organization the cost of poor quality in products and services.
- Driving out fear and bringing problems to light for all to see.
- Working together to address specific problems and establish goals and solutions as a team.
- Controlling manufacturing processes which determine the final cost and quality of our products.
- Removing barriers which stand between employees and their pride of workmanship, and implementing ongoing training, supervision and employee development programs.
- Good housekeeping, which reflects on the company, its operating philosophy and our people.



BFE is specialized in the production of industrial valves for use in oil & gas, chemical, petrochemical, power, onshore and offshore industries. BFE has two main divisions:

- Albano Sant'Alessandro - BG - Italy: The management sales and operative offices are located here, as well as the machining, assembly and final testing workshop for forged valves
- BFE forging plant - BG - Italy: The main components for forged valves are forged and represent BFE's first basic factor of global quality, seeing that the entire manufacturing process is controlled and guaranteed by the Company Quality System.



Bonney Forge is an industry leader in marketing and manufacturing forged steel fittings and unions, branch connections, forged steel valves, cast steel valves and specialty products.

For more than a century, Bonney Forge has achieved manufacturing excellence through the detailed attention to customer's needs and producing consistently superior flow control products. Today, the Bonney Forge name is synonymous with quality that exceeds all industry standards.



WFI International, a Bonney Forge Company, is a leading manufacturer of ferrous and non-ferrous branch connection fittings, specialty flanges, and seamless fittings for use in piping systems and on pressure vessels. WFI and Bonney Forge are the world's leading manufacturers of integrally reinforced branch connection fittings.



Bonney Forge acquired RP&C Valve in 2004. RP&C traces its' origin back to 1878 with the Steam Boiler Appliance Company. RP&C products consist of Forged Steel Valves used in the chemical processing, pulp and paper, petroleum, power, and residential and commercial construction markets.

COMPANY BACKGROUND

BONNEY FORGE CORPORATION ACQUIRES BFE

Bonney Forge Corporation has expanded its global footprint in manufacturing industrial valves and fittings by completing the purchase of BFE. As one of the world's leading manufacturers of forged steel valves, cast steel valves, forged steel fittings, unions and branch connections, our commitment to excellence in producing the highest quality products makes this acquisition a significant alliance in the international market.

2013

SECURING OUR GLOBAL PRESENCE BY INVESTING IN OURSELVES.



BONNEY FORGE

ENHANCED APPROACHES TO ENVIRONMENTAL AND ECOLOGICAL MANAGEMENT

As well as guaranteeing maximum functionality, all valves made by B.F.E. S.p.A. fully comply with international and EU norms to reduce atmospheric pollution and leakage also under critical conditions such as high pressures, temperatures and the presence of aggressive products, etc.

2004



DYNAMISM, INNOVATION AND GROWTH

A significant year for B.F.E. S.p.A. Bonney Forge Valve Licensee as Acciaierie Valbruna di Vicenza, one of the world's largest steel companies, comes in as controlling shareholder. The US-based Bonney Forge Corporation continues to maintain its position as a shareholder and licensor.

1996

BONNEY FORGE EUROPE BECOMES B.F.E. S.P.A.

In 1987 the current B.F.E. S.p.A. Bonney Forge Valve Licensee is created: the company was acquired from Bonney Forge Corporation; however the latter remains a shareholder and licensor.

1987



1966

BONNEY FORGE EUROPE IS FOUNDED

December 1966. Bonney Forge Europe S.p.A. is officially incorporated. The Firm continues to operate mainly in energy production and the petrolchemical industry. In order to meet increasingly sophisticated and complex market demands, Bonney Forge Europe buys a production plant exclusively dedicated to forging.

1955

FIRST DAYS, A PROMISE OF QUALITY AND COMMITMENT

Forged valves production first started as long ago as 1955 in a converted warehouse in Albano S. Alessandro originally built as a barn. The production was the responsibility of four people but in just a few years there were thirty on the payroll - thanks to a policy of steadfast commitment and the winning of a series of important orders from Italy's fast growing chemical and petrolchemical industries.

O.M.B.A.
Bergamo

VALVOLE &
RACCORDI
FORGIATI

B A-3

... in questo Catalogo

TAKING QUALITY TO THE NEXT LEVEL

ENGINEERING IN A QUALITY DRIVEN MARKET

Our extensive, uncompromising, company-wide quality control system carefully monitors our manufacturing processes to assure a product that performs to the highest industry standards.

Quality assurance procedures include 100% hydrostatic and pneumatic testing of all valves in full conformance to applicable API standards and industry codes.



QUALITY THAT YOU CAN COUNT ON

BFE products are manufactured and tested in strict accordance to ASTM, ASME, ANSI, API and other applicable industry codes and specifications.

Chemical and mechanical properties of all Bonney Forge products are fully traceable to the original forging lot and raw material heat. Requirements of the market are in a state of constant evolution, and customers' quality needs are met and exceeded by the complete business process.

THE ASSURANCE YOU NEED

It is our policy to supply only quality products that conform fully to customer and statutory or regulatory requirements including codes and standards. To help meet our objective we operate an exacting quality control system, which has been audited and assessed by numerous customers and external authorities for compliance with all market standards.

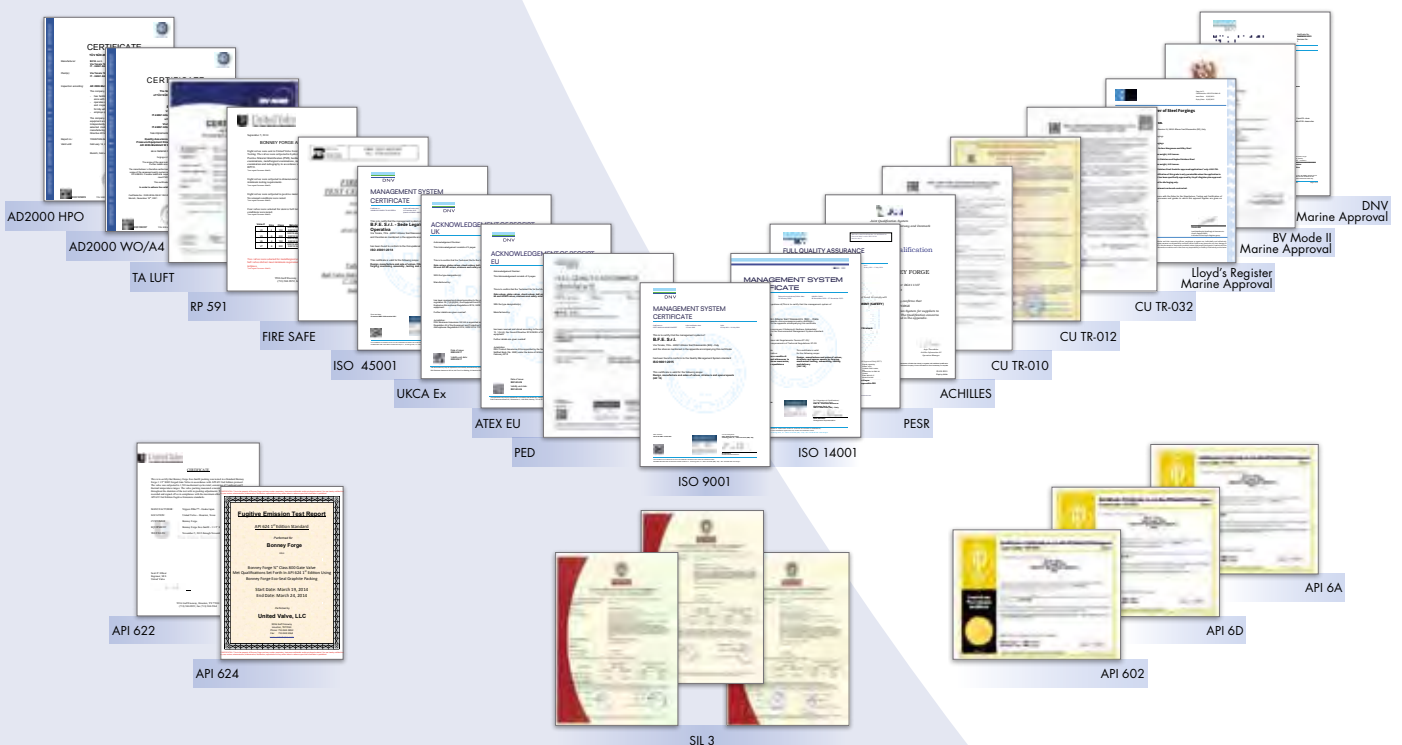

CONFIDENCE IN STEEL FORGING

WHY FORGINGS?

Forging offers uniformity of composition and structure. Forging results in metallurgical recrystallisation and grain refinement as a result of the thermal cycle and deformation process.

This strengthens the resulting steel product particularly in terms of impact and shear strength. Forged steel is generally stronger and more reliable than castings and plate steel due to the fact that the grain flows of the steel are altered, conforming to the shape of the part.

WHAT YOU GAIN WHEN YOU SELECT OUR FORGINGS

- Dimensional uniformity and close dimensional tolerances.
- High Strength.
- Tougher than alternatives.
- Better response to heat treatment than alternatives.
- Will handle impact better than alternatives.
- The nature of forging excludes the occurrence of porosity, shrinkage, cavities and cold pour issues.
- The tight grain structure of forgings making it mechanically strong.
- The tight grain structure offers great wear resistance.

IN-HOUSE FORGING PRODUCTION

Thanks to constant search of efficient solutions the plant has the most modern forging production built on basis of semi-automatic and continuous forging line. High quality of forging is provided by the modern production accessories of the plant and usage of software for modeling the process of forging.

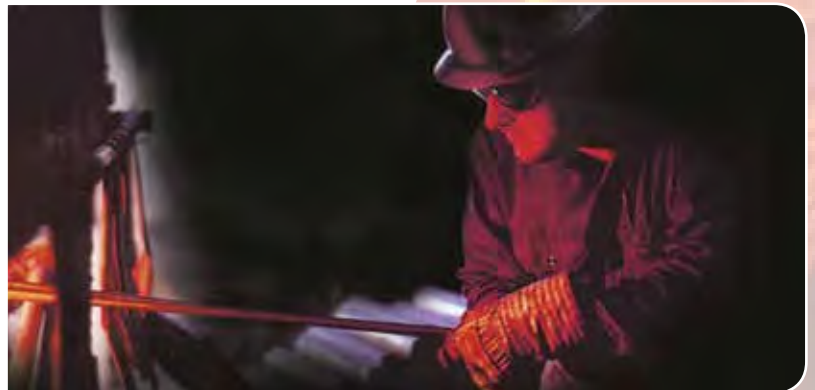

HIGHEST POSSIBLE MATERIAL QUALITY

BFE uses only high-quality materials inspected & tested to International Standards and utilizes advanced manufacturing technology with special emphasis on safety, quality, and long service life of our products, to ensure that our clients receive the "best in class" products available from us at a competitive price and delivered on time.

CHALLENGING MATERIALS FOR THE MOST CRITICAL APPLICATIONS

Forging material has increased strength under maximum rated operation pressure compared with cast. Other forging properties include greater impact resistance, resistance to fatigue cracking, particularly when cycling at either high or cryogenic temperature.



UNIQUE EXPERTISE FOR VALVE ENGINEERING

BFE offers extensive expertise in the design that provide the advantage of sophisticated product development with fast and cost-effective manufacturing capabilities.

Our approach ensures that you receive the lowest cost, and highest efficiency solution with a quick turn-around.

Bonney Forge represent decades of design experience across all market sectors. Using the latest software and design technologies, our Engineering can take your requirements and develop a specific custom solution.

BFE Engineering Department operates state of the art design tools with last generation solid modeling, linear and non linear finite element analysis and computational fluid dynamic analysis.

FMEA and FMECA tools are used to minimize the development risks and increase product reliability during the development of new products.

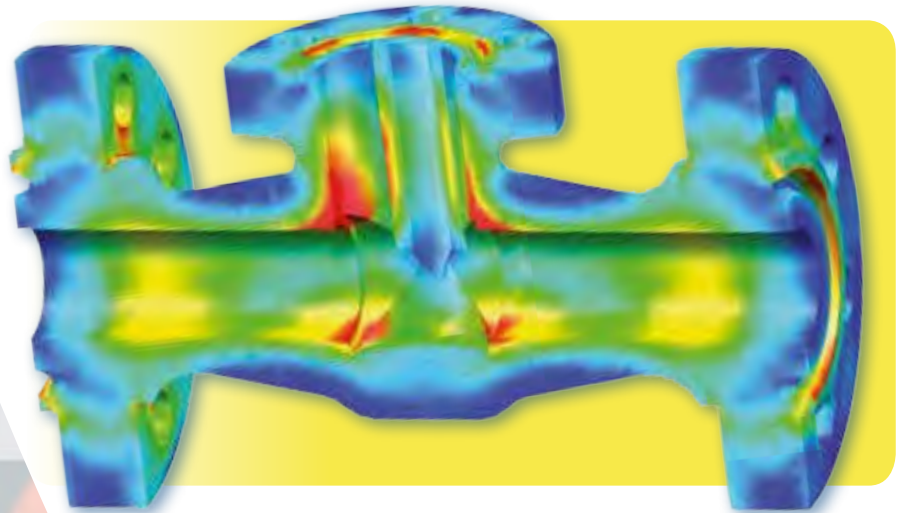

PRODUCTION CAPABILITIES THAT MEET YOUR DEMANDS

BFE is an integrated supplier with in-house forging, machining and assembly-test operations.

Continuous investment in computerized systems and integrated machining centres ensure the highest level of component repeatability, high volume capabilities with uncompromising quality.

BFE experience in managing the complete production process for complex and highly variable requirements benefits our customers by achieving a high rate of on-time delivery and the ability to meet some of the most demanding fast track shipments.

Combined with unlimited local qualified third party capabilities,

BFE production system is constantly expanding to handle steady growth rates and complex customer requirements.



GATE VALVES

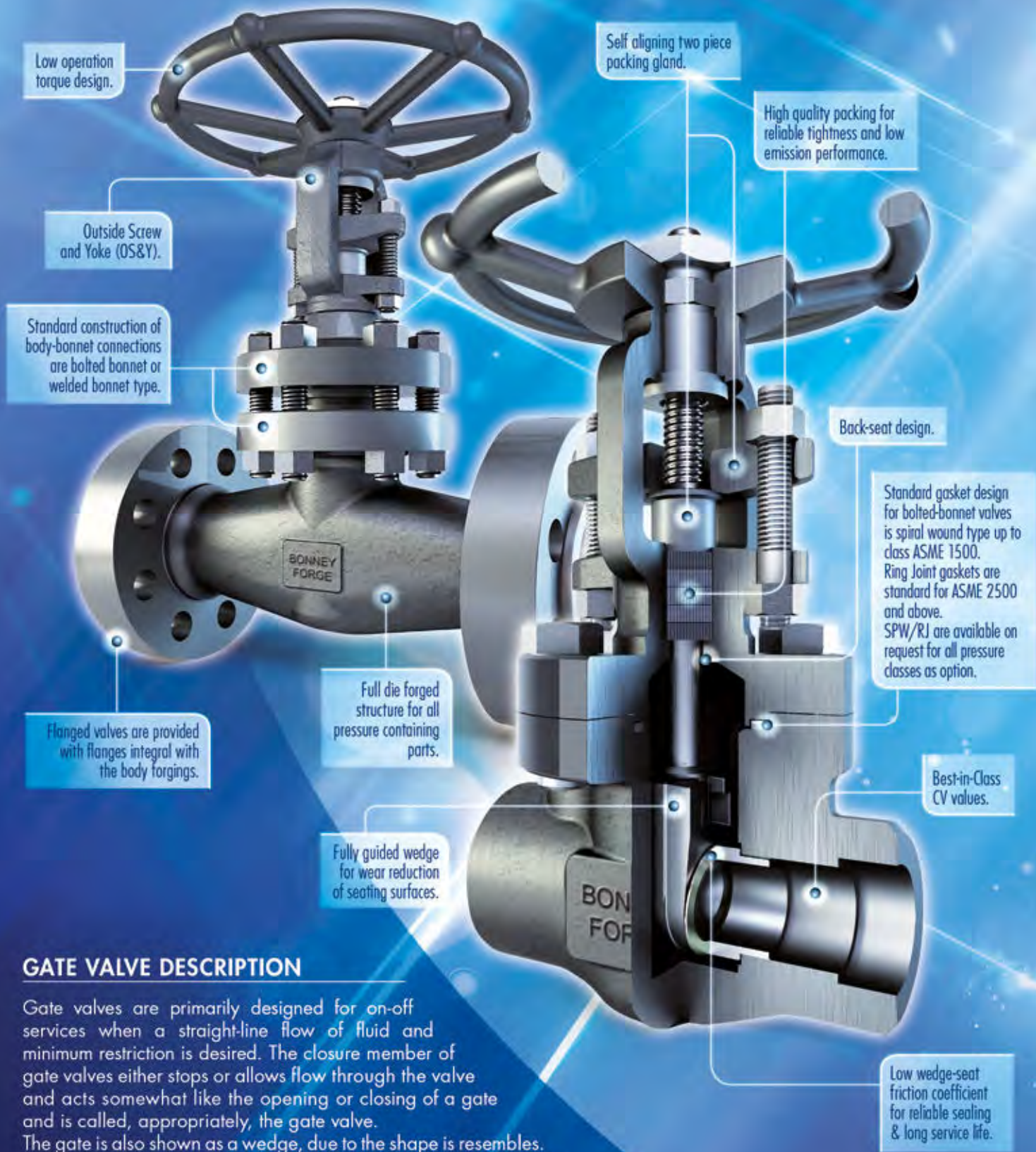

GATE VALVE DESCRIPTION

Gate valves are primarily designed for on-off services when a straight-line flow of fluid and minimum restriction is desired. The closure member of gate valves either stops or allows flow through the valve and acts somewhat like the opening or closing of a gate and is called, appropriately, the gate valve.

The gate is also shown as a wedge, due to the shape it resembles. When the valve is open, the closure member is fully drawn up into the valve, leaving a complete opening for the flow stream. Therefore, there is little pressure drop or flow restriction through the valve. Gate valves are used in many industrial applications including the oil and gas industry, pharmaceuticals, manufacturing, automotive, and marine. Gate valves are not suitable for throttling purposes.









P&ID SYMBOL









STANDARD CONFIGURATIONS



SECTION INDEX OF GATE VALVES

PAGE	DESCRIPTION	SYM
B-3	BOLTED BONNET GATE VALVES BASIC CONFIGURATION THREADED AND SOCKET WELD ENDS	
B-4	BOLTED BONNET GATE VALVES BASIC CONFIGURATION ASME INTEGRAL FLANGED ENDS	
B-5	BOLTED BONNET GATE VALVES CRYOGENIC CONFIGURATION THREADED AND SOCKET WELD ENDS	
B-6	BOLTED BONNET GATE VALVES CRYOGENIC CONFIGURATION ASME INTEGRAL FLANGED ENDS	
B-7	BOLTED BONNET GATE VALVES BELLOW SEAL CONFIGURATION THREADED AND SOCKET WELD ENDS	
B-8	BOLTED BONNET GATE VALVES BELLOW SEAL CONFIGURATION ASME INTEGRAL FLANGED ENDS	
B-9	WELDED BONNET GATE VALVES BASIC CONFIGURATION THREADED AND SOCKET WELD ENDS	
B-10	WELDED BONNET GATE VALVES BASIC CONFIGURATION ASME INTEGRAL FLANGED ENDS	
B-11	WELDED BONNET GATE VALVES CRYOGENIC CONFIGURATION THREADED AND SOCKET WELD ENDS	

PAGE	DESCRIPTION	SYM
B-12	WELDED BONNET GATE VALVES CRYOGENIC CONFIGURATION ASME INTEGRAL FLANGED ENDS	
B-13	WELDED BONNET GATE VALVES BELLOW SEAL CONFIGURATION THREADED AND SOCKET WELD ENDS	
B-14	WELDED BONNET GATE VALVES BELLOW SEAL CONFIGURATION ASME INTEGRAL FLANGED ENDS	
B-15	BOLTED BONNET GATE VALVES INTEGRAL REINFORCED EXTENDED BODY CONFIGURATION VALVOLET AND LIP ENDS VALVES	
B-15	BOLTED BONNET GATE VALVES EXTENDED BODY CONFIGURATION THREADED AND WELDING ENDS VALVES	
B-16	WELDED BONNET GATE VALVES INTEGRAL REINFORCED EXTENDED BODY CONFIGURATION VALVOLET AND LIP ENDS VALVES	
B-16	WELDED BONNET GATE VALVES EXTENDED BODY CONFIGURATION THREADED AND WELDING ENDS VALVES	
B-17	AVAILABLE OPTIONS FOR GATE VALVES	

APPLICABLE STANDARDS	
DESIGN	API 602 - ISO 15761 - ASME B16.34
INSPECTION & TESTING	API 598
MARKING	MSS SP-25
RATING	ASME B16.34
FUGITIVE EMISSION	API 624 - ISO 15848

GATE VALVES

BOLTED BONNET GATE VALVES BASIC CONFIGURATION THREADED AND SOCKET WELD ENDS



WORKING PRESSURE RATING	SIZE		STANDARD DESIGN TYPE	A		B		C		H		WEIGHT		FIGURE
	NPS	DN		mm	in	mm	in	mm	in	mm	in	kg	lb	
ASME 800	1/2"	15	S1	80	3.15	9.6	0.38	88	3.5	152	6.0	1.9	4.2	HL 103
	3/4"	20	S1	90	3.54	14	0.55	88	3.5	158	6.2	2.3	5.1	HL 104
	1"	25	S1	110	4.33	18	0.71	97	3.8	196	7.7	3.6	7.9	HL 105
	1-1/2"	40	S1	127	5.00	30	1.18	138	5.4	255	10.0	7.3	16.1	HL 107
	2"	50	S1	134	5.28	37.5	1.47	138	5.4	290	11.4	7.6	16.8	HL 108
ASME 1500	1/2"	15	S1	90	3.54	9.6	0.38	88	3.5	152	6.0	2.4	5.3	9HL 103
	3/4"	20	S1	110	4.33	14	0.55	97	3.8	190	7.5	3.9	8.6	9HL 104
	1"	25	S1	127	5.00	18	0.71	138	5.4	220	8.7	6.1	13.4	9HL 105
	1-1/2"	40	S1	127	5.00	30	1.18	138	5.4	282	11.1	10.8	23.8	9HL 107
	2"	50	S1	210	8.27	37.5	1.47	138	5.4	345	13.6	20.5	45.2	9HL 108
ASME 800	1/4"	6	S1	80	3.15	8	0.31	88	3.5	152	6.0	2.1	4.6	H 101
	3/8"	10	S1	80	3.15	9.6	0.38	88	3.5	152	6.0	2.1	4.6	H 102
	1/2"	15	S1	90	3.54	14	0.55	88	3.5	158	6.2	2.3	5.1	H 103
	3/4"	20	S1	110	4.33	18	0.71	97	3.8	196	7.7	3.7	8.2	H 104
	1"	25	S1	127	5.00	24	0.94	138	5.4	225	8.9	5.9	13.0	H 105
	1-1/4"	32	S1	127	5.00	30	1.18	138	5.4	255	10.0	7.4	16.3	H 106
	1-1/2"	40	S1	134	5.28	37.5	1.47	138	5.4	290	11.4	8.3	18.3	H 107
	2"	50	S1	152	5.98	48	1.89	172	6.8	358	14.1	12.5	27.6	H 108
ASME 1500	1/4"	6	S1	90	3.54	8	0.31	88	3.5	153	6.0	2.4	5.3	9H 101
	3/8"	10	S1	90	3.54	9.6	0.38	88	3.5	153	6.0	2.4	5.3	9H 102
	1/2"	15	S1	110	4.33	14	0.55	97	3.8	190	7.5	4.1	9.0	9H 103
	3/4"	20	S1	127	5.00	18	0.71	138	5.4	220	8.7	6.2	13.7	9H 104
	1"	25	S1	127	5.00	24	0.94	138	5.4	250	9.8	8	17.6	9H 105
	1-1/4"	32	S1	127	5.00	30	1.18	138	5.4	282	11.1	10.5	23.1	9H 106
	1-1/2"	40	S1	127	5.00	37.5	1.47	138	5.4	290	11.4	11	24.3	9H 107
	2"	50	S1	210	8.27	50	1.96	172	6.8	345	13.6	20	44.1	9H 108
ASME 2500	1/2"	15	S2	150	5.91	11.5	0.45	138	5.4	282	11.1	10	22.0	25HR 103
	3/4"	20	S2	150	5.91	15	0.59	138	5.4	287	11.3	10	22.0	25HR 104
	1"	25	S2	210	8.27	19.5	0.77	172	6.8	348	13.7	22	48.5	25HR 105
	1-1/2"	40	S2	230	9.06	28	1.10	234	9.2	406	16.0	37	81.6	25HR 107
	2"	50	S2	230	9.06	35	1.38	234	9.2	437	17.2	36	86	25HR 108

STANDARD BORE

FULL BORE

BFE reserves the right to change designs, dimensions or specifications without notice.

PRODUCT FEATURES:

- Socket Weld acc. to ASME B16.11. • Screwed ends (NPT) acc. to ASME B1.20.1. • Butt welding ends acc. to ASME B16.25. • End to End acc. to manufacturer standard.

DESIGN TYPE S1 SPIRAL WOUND GASKET BODY-BONNET CONNECTION

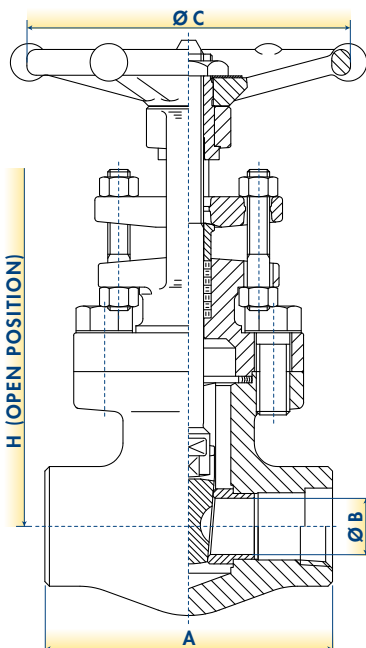

DESIGN TYPE S2 RING JOINT GASKET BODY-BONNET CONNECTION

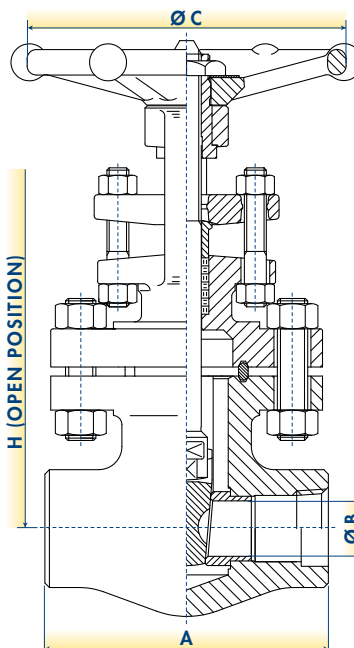

OTHER END CONNECTION TYPES AVAILABLE

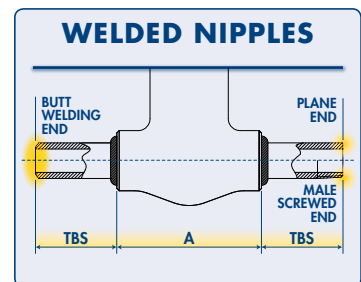
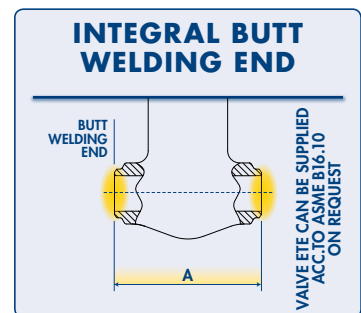

BOLTED BONNET GATE VALVES BASIC CONFIGURATION ASME INTEGRAL FLANGED ENDS



WORKING PRESSURE RATING	SIZE		STANDARD DESIGN TYPE	A-RF		A-RJ		B		C		H		WEIGHT		FIGURE
	NPS	DN		mm	in	mm	in	mm	in	mm	in	mm	in	kg	lb	
ASME 150	1/2"	15	S1	108	4.25	N.A.	N.A.	9.6	0.38	88	3.5	175	6.9	2.9	6.3	L1-103
	3/4"	20	S1	117	4.62	N.A.	N.A.	14	0.55	88	3.5	182	7.2	3.7	8.2	L1-104
	1"	25	S1	127	5.00	140	5.50	18	0.71	97	3.8	212	8.3	5.2	11.5	L1-105
	1-1/2"	40	S1	165	6.50	178	7.00	30	1.18	138	5.4	255	10.0	9.6	21.2	L1-107
	2"	50	S1	178	7.00	191	7.50	37.5	1.47	138	5.4	290	11.4	13.2	29.1	L1-108
ASME 300	1/2"	15	S1	140	5.50	151	5.94	9.6	0.38	88	3.5	175	6.9	3.6	7.9	L3-103
	3/4"	20	S1	152	6.00	165	6.50	14	0.55	88	3.5	182	7.2	5.2	11.5	L3-104
	1"	25	S1	165	6.50	178	7.00	18	0.71	97	3.8	212	8.3	6.7	14.8	L3-105
	1-1/2"	40	S1	190	7.50	203	8.00	30	1.18	138	5.4	240	9.4	13	28.7	L3-107
	2"	50	S1	216	8.50	232	9.12	37.5	1.47	138	5.4	290	11.4	15.3	33.7	L3-108
ASME 600	1/2"	15	S1	165	6.50	163	6.44	9.6	0.38	88	3.5	159	6.3	4.3	9.5	L6-103
	3/4"	20	S1	190	7.50	190	7.50	14	0.55	88	3.5	185	7.3	7	15.4	L6-104
	1"	25	S1	216	8.50	216	8.50	18	0.71	97	3.8	215	8.5	10	22.0	L6-105
	1-1/2"	40	S1	241	9.50	241	9.50	30	1.18	138	5.4	255	10.0	18	39.7	L6-107
	2"	50	S1	292	11.50	295	11.62	37.5	1.47	138	5.4	305	12.0	28	61.7	L6-108
ASME 1500	1/2"	15	S1	216	8.50	216	8.50	9.5	0.37	88	3.5	185	7.3	7.5	16.5	15FL 103
	3/4"	20	S1	229	9.00	229	9.00	14	0.55	97	3.8	215	8.5	12	26.5	15FL 104
	1"	25	S1	254	10.00	254	10.00	18	0.71	138	5.4	245	9.6	15	33.0	15FL 105
	1-1/2"	40	S1	305	12.00	305	12.00	30	1.18	172	6.8	295	11.6	28.2	62.2	15FL 107
	2"	50	S1	368	14.50	371.5	14.62	37.5	1.47	172	6.8	330	13.0	53	116.8	15FL 108
ASME 150	1/2"	15	S1	108	4.25	N.A.	N.A.	14	0.55	88	3.5	175	6.9	3.2	7.0	1-103
	3/4"	20	S1	117	4.62	N.A.	N.A.	18	0.71	97	3.8	210	8.3	4.7	10.4	1-104
	1"	25	S1	127	5.00	140	5.50	24	0.94	138	5.4	230	9.1	6.1	13.4	1-105
	1-1/2"	40	S1	165	6.50	178	7.00	37.5	1.47	138	5.4	290	11.4	11.4	25.1	1-107
	2"	50	S1	178	7.00	191	7.50	48	1.89	172	6.8	340	13.4	18	39.7	1-108
ASME 300	1/2"	15	S1	140	5.50	151	5.94	14	0.55	88	3.5	175	6.9	3.8	8.4	3-103
	3/4"	20	S1	152	6.00	165	6.50	18	0.71	97	3.8	210	8.3	5.6	12.3	3-104
	1"	25	S1	165	6.50	178	7.00	24	0.94	138	5.4	230	9.1	7.1	15.7	3-105
	1-1/2"	40	S1	190	7.50	203	8.00	37.5	1.47	138	5.4	290	11.4	13.5	29.8	3-107
	2"	50	S1	216	8.50	232	9.12	48	1.89	172	6.8	340	13.4	19	41.9	3-108
ASME 600	1/2"	15	S1	165	6.50	163	6.44	14	0.55	88	3.5	175	6.9	4.3	9.5	6-103
	3/4"	20	S1	190	7.50	190	7.50	18	0.71	97	3.8	215	8.5	7	15.4	6-104
	1"	25	S1	216	8.50	216	8.50	24	0.94	138	5.4	240	9.4	10	22.0	6-105
	1-1/2"	40	S1	241	9.50	241	9.50	37.5	1.47	138	5.4	295	11.6	18	39.7	6-107
	2"	50	S1	292	11.50	295	11.62	48	1.89	172	6.8	360	14.2	28	61.7	6-108
ASME 1500	1/2"	15	S1	216	8.50	216	8.50	14	0.55	97	3.8	215	8.5	8.2	18.0	15F 103
	3/4"	20	S1	229	9.00	229	9.00	18	0.71	138	5.4	250	9.8	13	28.7	15F 104
	1"	25	S1	254	10.00	254	10.00	24	0.94	138	5.4	270	10.6	16.2	35.7	15F 105
	1-1/2"	40	S1	305	12.00	305	12.00	37.5	1.47	172	6.8	350	13.8	29	64.0	15F 107
	2"	50	S1	368	14.50	371.5	14.62	48	1.89	234	9.2	445	17.5	55	121.3	15F 108
ASME 2500	1/2"	15	S2	264	10.38	264	10.38	11.5	0.45	138	5.4	282	11.1	16.2	35.7	25RF 103
	3/4"	20	S2	273	10.75	273	10.75	15	0.59	138	5.4	290	11.4	17.6	38.8	25RF 104
	1"	25	S2	308	12.12	308	12.12	19.5	0.77	172	6.8	335	13.2	29	63.9	25RF 105
	1-1/2"	40	S2	384	15.12	387	15.24	28	1.10	234	9.2	406	16.0	60	132.3	25RF 107
	2"	50	S2	451	17.75	454	17.87	38	1.50	320	12.6	415	16.3	65	143.3	25RF 108

STANDARD BORE

FULL BORE

BFE reserves the right to change designs, dimensions or specifications without notice.

PRODUCT FEATURES:

- Flanged ends acc. to ASME B16.5.
- Face to Face acc. to ASME B16.10.

DESIGN TYPE S1

SPIRAL WOUND GASKET BODY-BONNET CONNECTION

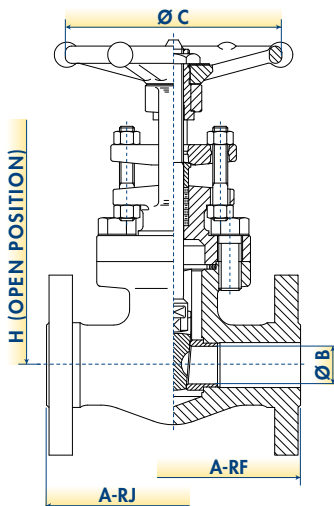

DESIGN TYPE S2

RING JOINT GASKET BODY-BONNET CONNECTION

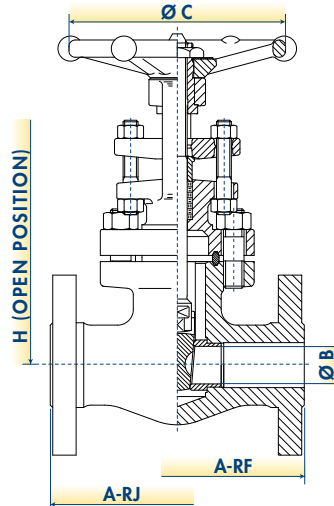

GATE VALVES

BOLTED BONNET GATE VALVES CRYOGENIC CONFIGURATION THREADED AND SOCKET WELD ENDS



WORKING PRESSURE RATING	SIZE		STANDARD DESIGN TYPE	A		B		C		H		WEIGHT		FIGURE
	NPS	DN		mm	in	mm	in	mm	in	mm	in	kg	lb	
ASME 800	1/2"	15	S1	80	3.15	9.6	0.38	88	3.5	406	16.0	3.4	7.5	CL 103
	3/4"	20	S1	90	3.54	14	0.55	88	3.5	412	16.2	3.5	7.7	CL 104
	1"	25	S1	110	4.33	18	0.71	97	3.8	450	17.7	5	11.0	CL 105
	1-1/2"	40	S1	127	5.00	30	1.18	138	5.4	509	20.0	9.6	21.2	CL 107
	2"	50	S1	134	5.28	37.5	1.47	138	5.4	544	21.4	12.5	27.6	CL 108
ASME 1500	1/2"	15	S1	90	3.54	9.6	0.38	88	3.5	406	16.0	3.7	8.2	9CL 103
	3/4"	20	S1	110	4.33	14	0.55	97	3.8	444	17.5	5.3	11.7	9CL 104
	1"	25	S1	127	5.00	18	0.71	138	5.4	474	18.7	8.5	18.7	9CL 105
	1-1/2"	40	S1	127	5.00	30	1.18	138	5.4	536	21.1	13.6	30.0	9CL 107
	2"	50	S1	210	8.27	37.5	1.47	138	5.4	599	23.6	26	57.3	9CL 108
ASME 800	1/4"	6	S1	80	3.15	8	0.31	88	3.5	406	16.0	3.4	7.5	C 101
	3/8"	10	S1	80	3.15	9.6	0.38	88	3.5	406	16.0	3.4	7.5	C 102
	1/2"	15	S1	90	3.54	14	0.55	88	3.5	412	16.2	3.5	7.7	C 103
	3/4"	20	S1	110	4.33	18	0.71	97	3.8	450	17.7	5.1	11.2	C 104
	1"	25	S1	127	5.00	24	0.94	138	5.4	479	18.9	8.2	18.1	C 105
	1-1/4"	32	S1	127	5.00	30	1.18	138	5.4	509	20.0	12	26.5	C 106
	1-1/2"	40	S1	134	5.28	37.5	1.47	138	5.4	544	21.4	16	35.3	C 107
	2"	50	S1	152	5.98	48	1.89	172	6.8	612	24.1	23	50.7	C 108
ASME 1500	1/4"	6	S1	90	3.54	8	0.31	88	3.5	407	16.0	3.5	7.7	9C 101
	3/8"	10	S1	90	3.54	9.6	0.38	88	3.5	407	16.0	3.5	7.7	9C 102
	1/2"	15	S1	110	4.33	14	0.55	97	3.8	444	17.5	5.5	12.1	9C 103
	3/4"	20	S1	127	5.00	18	0.71	138	5.4	474	18.7	7.8	17.2	9C 104
	1"	25	S1	127	5.00	24	0.94	138	5.4	504	19.8	11	24.3	9C 105
	1-1/4"	32	S1	127	5.00	30	1.18	138	5.4	536	21.1	14.5	32.0	9C 106
	1-1/2"	40	S1	127	5.00	37.5	1.47	138	5.4	544	21.4	25.6	56.4	9C 107
	2"	50	S1	210	8.27	50	1.96	172	6.8	599	23.6	43	94.8	9C 108
ASME 2500	1/2"	15	S2	150	5.91	11.5	0.45	138	5.4	536	21.1	13	28.7	25CHR 103
	3/4"	20	S2	150	5.91	15	0.59	138	5.4	541	21.3	13	28.7	25CHR 104
	1"	25	S2	210	8.27	19.5	0.77	172	6.8	602	23.7	26	57.3	25CHR 105
	1-1/2"	40	S2	230	9.06	28	1.10	234	9.2	660	26.0	42	92.6	25CHR 107
	2"	50	S2	230	9.06	35	1.38	234	9.2	691	27.2	43	94.8	25CHR 108

STANDARD BORE

FULL BORE

BFE reserves the right to change designs, dimensions or specifications without notice.

PRODUCT FEATURES:

- Socket Weld acc. to ASME B16.11. • Screwed ends (NPT) acc. to ASME B1.20.1. • Butt welding ends acc. to ASME B16.25. • End to End acc. to manufacturer standard. • Cryogenic design acc. to BS 6364. • Body Cavity Vent Hole.

DESIGN TYPE S1 SPIRAL WOUND GASKET BODY-BONNET CONNECTION

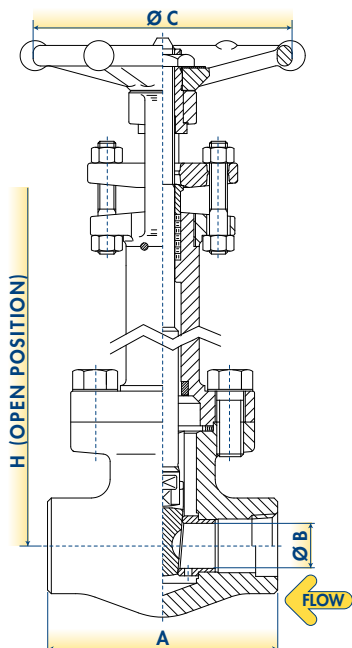

DESIGN TYPE S2 RING JOINT GASKET BODY-BONNET CONNECTION

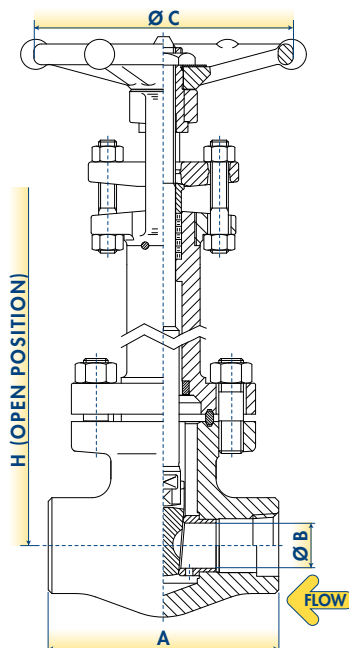

OTHER END CONNECTION TYPES AVAILABLE

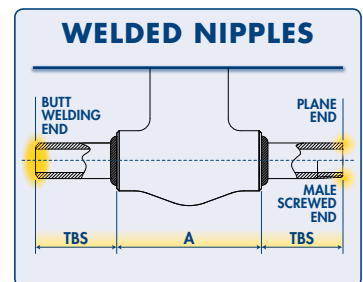
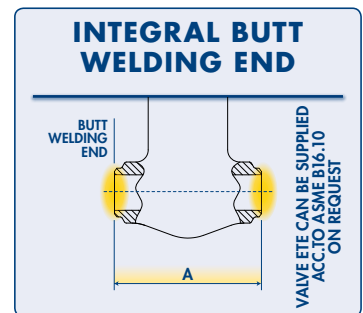

BOLTED BONNET GATE VALVES CRYOGENIC CONFIGURATION ASME INTEGRAL FLANGED ENDS



WORKING PRESSURE RATING	SIZE		STANDARD DESIGN TYPE	A-RF		A-RJ		B		C		H		WEIGHT		FIGURE
	NPS	DN		mm	in	mm	in	mm	in	mm	in	mm	in	kg	lb	
ASME 150	1/2"	15	S1	108	4.25	N.A.	N.A.	9.6	0.38	88	3.5	429	16.9	4.3	9.5	1CL 103
	3/4"	20	S1	117	4.62	N.A.	N.A.	14	0.55	88	3.5	436	17.2	5.1	11.2	1CL 104
	1"	25	S1	127	5.00	140	5.50	18	0.71	97	3.8	466	18.3	6.4	14.1	1CL 105
	1-1/2"	40	S1	165	6.50	178	7.00	30	1.18	138	5.4	509	20.0	12.4	27.3	1CL 107
	2"	50	S1	178	7.00	191	7.50	37.5	1.47	138	5.4	544	21.4	16	35.3	1CL 108
ASME 300	1/2"	15	S1	140	5.50	151	5.94	9.6	0.38	88	3.5	429	16.9	5.1	11.2	3CL 103
	3/4"	20	S1	152	6.00	165	6.50	14	0.55	88	3.5	436	17.2	6.5	14.3	3CL 104
	1"	25	S1	165	6.50	178	7.00	18	0.71	97	3.8	466	18.3	7.8	17.2	3CL 105
	1-1/2"	40	S1	190	7.50	203	8.00	30	1.18	138	5.4	494	19.4	15	33.1	3CL 107
	2"	50	S1	216	8.50	232	9.12	37.5	1.47	138	5.4	544	21.4	19	41.9	3CL 108
ASME 600	1/2"	15	S1	165	6.50	163	6.44	9.6	0.38	88	3.5	413	16.3	5.3	11.7	6CL 103
	3/4"	20	S1	190	7.50	190	7.50	14	0.55	88	3.5	439	17.3	7.4	16.3	6CL 104
	1"	25	S1	216	8.50	216	8.50	18	0.71	97	3.8	469	18.5	13	28.7	6CL 105
	1-1/2"	40	S1	241	9.50	241	9.50	30	1.18	138	5.4	509	20.0	21	46.3	6CL 107
	2"	50	S1	292	11.50	295	11.62	37.5	1.47	138	5.4	559	22.0	32	70.5	6CL 108
ASME 1500	1/2"	15	S1	216	8.50	216	8.50	9.5	0.37	88	3.5	439	17.3	10.2	22.5	15CFL 103
	3/4"	20	S1	229	9.00	229	9.00	14	0.55	97	3.8	469	18.5	14	30.9	15CFL 104
	1"	25	S1	254	10.00	254	10.00	18	0.71	138	5.4	499	19.6	17.5	38.6	15CFL 105
	1-1/2"	40	S1	305	12.00	305	12.00	30	1.18	172	6.8	549	21.6	31	68.3	15CFL 107
	2"	50	S1	368	14.50	371.5	14.62	37.5	1.47	172	6.8	584	23.0	59	130.1	15CFL 208
ASME 150	1/2"	15	S1	108	4.25	N.A.	N.A.	14	0.55	88	3.5	429	16.9	4.8	10.6	1C 103
	3/4"	20	S1	117	4.62	N.A.	N.A.	18	0.71	97	3.8	464	18.3	5.9	13.0	1C 104
	1"	25	S1	127	5.00	140	5.50	24	0.94	138	5.4	484	19.1	8.7	19.2	1C 105
	1-1/2"	40	S1	165	6.50	178	7.00	37.5	1.47	138	5.4	544	21.4	14.7	32.4	1C 107
	2"	50	S1	178	7.00	191	7.50	48	1.89	172	6.8	594	23.4	19	41.9	1C 108
ASME 300	1/2"	15	S1	140	5.50	151	5.94	14	0.55	88	3.5	429	16.9	5.1	11.2	3C 103
	3/4"	20	S1	152	6.00	165	6.50	18	0.71	97	3.8	464	18.3	7.2	15.9	3C 104
	1"	25	S1	165	6.50	178	7.00	24	0.94	138	5.4	484	19.1	9.9	21.8	3C 105
	1-1/2"	40	S1	190	7.50	203	8.00	37.5	1.47	138	5.4	544	21.4	16	35.3	3C 107
	2"	50	S1	216	8.50	232	9.12	48	1.89	172	6.8	594	23.4	22	48.5	3C 108
ASME 600	1/2"	15	S1	165	6.50	163	6.44	14	0.55	88	3.5	429	16.9	6.2	13.7	6C 103
	3/4"	20	S1	190	7.50	190	7.50	18	0.71	97	3.8	469	18.5	8.4	18.5	6C 104
	1"	25	S1	216	8.50	216	8.50	24	0.94	138	5.4	494	19.4	15	33.1	6C 105
	1-1/2"	40	S1	241	9.50	241	9.50	37.5	1.47	138	5.4	549	21.6	23	50.7	6C 107
	2"	50	S1	292	11.50	295	11.62	48	1.89	172	6.8	614	24.2	34	75.0	6C 108
ASME 1500	1/2"	15	S1	216	8.50	216	8.50	14	0.55	97	3.8	469	18.5	10.2	22.5	15CF 103
	3/4"	20	S1	229	9.00	229	9.00	18	0.71	138	5.4	504	19.8	14	30.9	15CF 104
	1"	25	S1	254	10.00	254	10.00	24	0.94	138	5.4	524	20.6	17.5	38.6	15CF 105
	1-1/2"	40	S1	305	12.00	305	12.00	37.5	1.47	172	6.8	604	23.8	31	68.3	15CF 107
	2"	50	S1	368	14.50	371.5	14.62	48	1.89	234	9.2	699	27.5	59	130.1	15CF 108
ASME 2500	1/2"	15	S2	264	10.38	264	10.38	11.5	0.45	138	5.4	536	21.1	20	44.1	25CRF 103
	3/4"	20	S2	273	10.75	273	10.75	15	0.59	138	5.4	544	21.4	22	48.5	25CRF 104
	1"	25	S2	308	12.12	308	12.12	19.5	0.77	172	6.8	589	23.2	32	70.5	25CRF 105
	1-1/2"	40	S2	384	15.12	387	15.24	28	1.10	234	9.2	660	26.0	65	143.3	25CRF 107
	2"	50	S2	451	17.75	454	17.87	38	1.50	320	12.6	669	26.3	80	154.3	25CRF 108

STANDARD BORE

FULL BORE

BFE reserves the right to change designs, dimensions or specifications without notice.

PRODUCT FEATURES:

- Flanged ends acc.to ASME B16.5. • Face to Face acc.to ASME B16.10. • Cryogenic design acc.to BS 6364. • Body Cavity Vent Hole.

DESIGN TYPE S1

SPIRAL WOUND GASKET BODY-BONNET CONNECTION

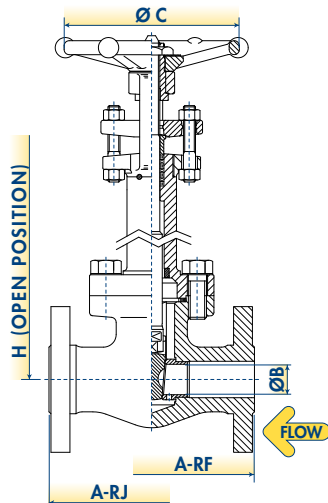

DESIGN TYPE S2

RING JOINT GASKET BODY-BONNET CONNECTION

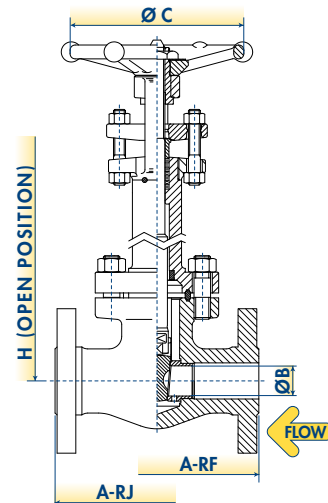

GATE VALVES

BOLTED BONNET GATE VALVES BELLOW SEAL CONFIGURATION THREADED AND SOCKET WELD ENDS



WORKING PRESSURE RATING	SIZE		STANDARD DESIGN TYPE	A		B		C		H		WEIGHT		FIGURE
	NPS	DN		mm	in	mm	in	mm	in	mm	in	kg	lb	
ASME 800	1/2"	15	P4	80	3.15	9.6	0.38	88	3.5	230	9.1	2.7	6.0	SL 103
	3/4"	20	P4	90	3.54	14	0.55	88	3.5	234	9.2	3	6.6	SL 104
	1"	25	P4	110	4.33	18	0.71	97	3.8	285	11.2	4.4	9.7	SL 105
	1-1/2"	40	P4	127	5.00	30	1.18	138	5.4	370	14.6	9.4	20.7	SL 107
	2"	50	P4	134	5.27	37.5	1.47	138	5.4	435	17.1	12.3	27.1	SL 108
ASME 1500	1/2"	15	P4	90	3.54	9.6	0.38	138	5.4	238	9.4	3	6.6	9SL 103
	3/4"	20	P4	110	4.33	14	0.55	138	5.4	293	11.5	5	11.0	9SL 104
	1"	25	P4	127	5.00	18	0.71	138	5.4	343	13.5	7	15.4	9SL 105
	1-1/2"	40	P4	127	5.00	30	1.18	234	9.2	450	17.7	10	22.0	9SL 107
	2"	50	P4	210	8.27	37.5	1.47	234	9.2	588	23.1	24	52.9	9SL 108
ASME 800	1/4"	6	P4	80	3.15	8	0.31	88	3.5	230	9.1	2.7	6.0	S 101
	3/8"	10	P4	80	3.15	9.6	0.38	88	3.5	230	9.1	2.7	6.0	S 102
	1/2"	15	P4	90	3.54	14	0.55	88	3.5	234	9.2	2.9	6.4	S 103
	3/4"	20	P4	110	4.33	18	0.71	97	3.8	285	11.2	4.6	10.1	S 104
	1"	25	P4	127	5.00	24	0.94	138	5.4	325	12.8	7.2	15.9	S 105
	1-1/4"	32	P4	127	5.00	30	1.18	138	5.4	370	14.6	10	22.0	S 106
	1-1/2"	40	P4	134	5.27	37.5	1.47	138	5.4	435	17.1	12.8	28.2	S 107
	2"	50	P4	152	6.00	48	1.89	172	6.8	530	20.9	22	48.5	S 108
ASME 1500	1/2"	15	P4	110	4.33	14	0.55	138	5.4	293	11.5	5	11.0	9S 103
	3/4"	20	P4	127	5.00	18	0.71	138	5.4	343	13.5	7	15.4	9S 104
	1"	25	P4	127	5.00	24	0.94	172	6.8	388	15.3	9.5	20.9	9S 105
	1-1/2"	40	P4	210	8.27	37.5	1.47	234	9.2	588	23.1	23.5	51.8	9S 107
	2"	50	P4	210	8.27	48	1.89	320	12.6	590	23.2	40	88.2	9S 108
ASME 2500	1/2"	15	P5	150	5.90	11.5	0.45	172	6.8	430	16.9	7	15.4	25SHR 103
	3/4"	20	P5	150	5.90	15	0.59	172	6.8	450	17.7	7	15.4	25SHR 104
	1"	25	P5	210	8.27	19.5	0.77	234	9.2	510	20.1	17	37.5	25SHR 105
	1-1/2"	40	P5	210	8.27	28	1.10	234	9.2	630	24.8	31	68.3	25SHR 107
	2"	50	P6	230	9.06	35	1.38	300	11.8	880	34.6	47	103.6	25SHR 108

STANDARD BORE

FULL BORE

BFE reserves the right to change designs, dimensions or specifications without notice.

PRODUCT FEATURES:

- Socket Weld acc. to ASME B16.11. • Screwed ends (NPT) acc. to ASME B1.20.1. • Butt welding ends acc. to ASME B16.25. • End to End acc. to manufacturer standard. • Zero emission. • Hydroformed Bellows
- Extension-Bonnet weld acc. to ASME IX. • Grease nipple for yoke sleeve. • Emergency stuffing box as back sealing.

DESIGN TYPE P4
HANDWHEEL OPERATED & SPIRAL WOUND GASKET BODY-BONNET CONNECTION

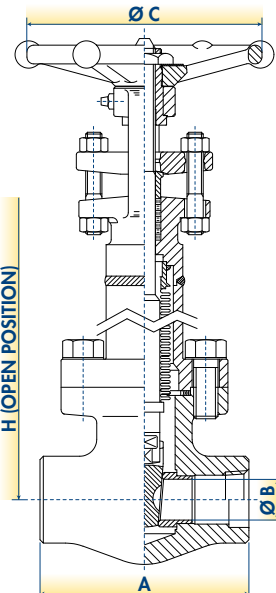

DESIGN TYPE P5
HANDWHEEL OPERATED WITH THRUST BEARINGS & RING JOINT GASKET BODY-BONNET CONNECTION

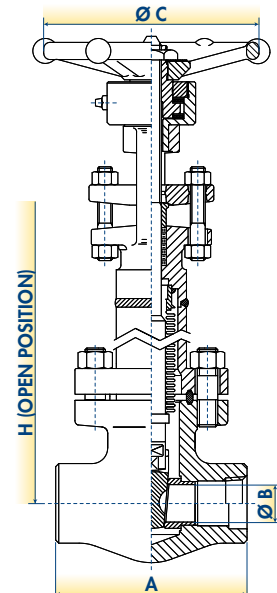

DESIGN TYPE P6
GEAR OPERATED & RING JOINT GASKET BODY-BONNET CONNECTION

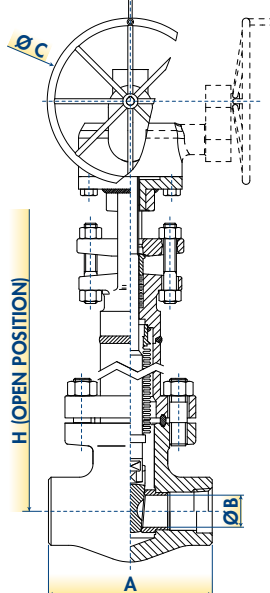

OTHER END CONNECTION TYPES AVAILABLE

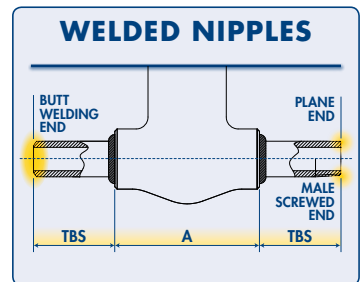
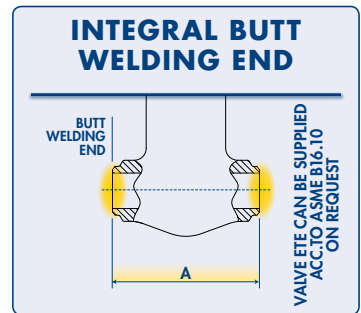

BOLTED BONNET GATE VALVES BELLOW SEAL CONFIGURATION ASME INTEGRAL FLANGED ENDS



WORKING PRESSURE RATING	SIZE		STANDARD DESIGN TYPE	A-RF		A-RJ		B		C		H		WEIGHT		FIGURE
	NPS	DN		mm	in	mm	in	mm	in	mm	in	mm	in	kg	lb	
ASME 150	1/2"	15	P4	108	4.25	N.A.	N.A.	9.6	0.38	88	3.5	193	7.6	5.2	11.6	1SL 103
	3/4"	20	P4	117	4.62	N.A.	N.A.	14	0.55	88	3.5	200	7.9	6.7	14.7	1SL 104
	1"	25	P4	127	5.00	140	5.00	18	0.71	97	3.8	233	9.2	9.4	20.7	1SL 105
	1-1/2"	40	P4	165	6.50	178	6.50	30	1.18	138	5.4	281	11.0	17.4	38.3	1SL 107
	2"	50	P4	178	7.00	191	7.00	37.5	1.47	138	5.4	319	12.6	23.9	52.6	1SL 108
ASME 300	1/2"	15	P4	140	5.50	151	5.50	9.6	0.38	88	3.5	193	7.6	6.5	14.3	3SL 103
	3/4"	20	P4	152	6.00	165	6.00	14	0.55	88	3.5	200	7.9	9.4	20.7	3SL 104
	1"	25	P4	165	6.50	178	6.50	18	0.71	97	3.8	233	9.2	12.1	26.7	3SL 105
	1-1/2"	40	P4	190	7.50	203	7.50	30	1.18	138	5.4	264	10.4	23.5	51.8	3SL 107
	2"	50	P4	216	8.50	232	8.50	37.5	1.47	138	5.4	319	12.6	27.7	61.0	3SL 108
ASME 600	1/2"	15	P4	165	6.50	163	6.50	9.6	0.38	88	3.5	175	6.9	7.8	17.1	6SL 103
	3/4"	20	P4	190	7.50	190	7.50	14	0.55	88	3.5	204	8.0	12.7	27.9	6SL 104
	1"	25	P4	216	8.50	216	8.50	18	0.71	97	3.8	237	9.3	18.1	39.9	6SL 105
	1-1/2"	40	P4	241	9.50	241	9.50	30	1.18	138	5.4	281	11.0	32.5	71.7	6SL 107
	2"	50	P4	292	11.50	295	11.50	37.5	1.47	138	5.4	336	13.2	50.6	111.6	6SL 108
ASME 1500	1/2"	15	P4	216	8.50	216	8.50	9.5	0.37	138	5.4	204	8.0	13.6	29.9	15SFL 103
	3/4"	20	P4	229	9.00	229	9.00	14	0.55	138	5.4	237	9.3	21.7	47.8	15SFL 104
	1"	25	P4	254	10.00	254	10.00	18	0.71	138	5.4	270	10.6	27.1	59.8	15SFL 105
	1-1/2"	40	P4	305	12.00	305	12.00	30	1.18	234	9.2	325	12.8	51.0	112.4	15SFL 107
	2"	50	P4	368	14.50	371.5	14.50	37.5	1.47	234	9.2	363	14.3	95.8	211.3	15SFL 108
ASME 150	1/2"	15	P4	108	4.25	N.A.	N.A.	14	0.55	88	3.5	193	7.6	5.8	12.8	1S 103
	3/4"	20	P4	117	4.62	N.A.	N.A.	18	0.71	97	3.8	231	9.1	8.5	18.7	1S 104
	1"	25	P4	127	5.00	140	5.00	24	0.94	138	5.4	253	10.0	11.0	24.3	1S 105
	1-1/2"	40	P4	165	6.50	178	6.50	37.5	1.47	138	5.4	319	12.6	20.6	45.4	1S 107
	2"	50	P4	178	7.00	191	7.00	48	1.89	172	6.8	374	14.7	32.5	71.7	1S 108
ASME 300	1/2"	15	P4	140	5.50	151	5.50	14	0.55	88	3.5	193	7.6	6.9	15.1	3S 103
	3/4"	20	P4	152	6.00	165	6.00	18	0.71	97	3.8	231	9.1	10.1	22.3	3S 104
	1"	25	P4	165	6.50	178	6.50	24	0.94	138	5.4	253	10.0	12.8	28.3	3S 105
	1-1/2"	40	P4	190	7.50	203	7.50	37.5	1.47	138	5.4	319	12.6	24.4	53.8	3S 107
	2"	50	P4	216	8.50	232	8.50	48	1.89	172	6.8	374	14.7	34.4	75.7	3S 108
ASME 600	1/2"	15	P4	165	6.50	163	6.50	14	0.55	88	3.5	193	7.6	7.8	17.1	6S 103
	3/4"	20	P4	190	7.50	190	7.50	18	0.71	97	3.8	237	9.3	12.7	27.9	6S 104
	1"	25	P4	216	8.50	216	8.50	24	0.94	138	5.4	264	10.4	18.1	39.9	6S 105
	1-1/2"	40	P4	241	9.50	241	9.50	37.5	1.47	138	5.4	325	12.8	32.5	71.7	6S 107
	2"	50	P4	292	11.50	295	11.50	48	1.89	172	6.8	396	15.6	50.6	111.6	6S 108
ASME 1500	1/2"	15	P4	216	8.50	216	8.50	14	0.55	138	5.4	237	9.3	14.8	32.7	15SF 103
	3/4"	20	P4	229	9.00	229	9.00	18	0.71	138	5.4	275	10.8	23.5	51.8	15SF 104
	1"	25	P4	254	10.00	254	10.00	24	0.94	172	6.8	297	11.7	29.3	64.6	15SF 105
	1-1/2"	40	P4	305	12.00	305	12.00	37.5	1.47	234	9.2	385	15.2	52.4	115.6	15SF 107
	2"	50	P4	368	14.50	371.5	14.50	48	1.89	320	12.6	490	19.3	99.4	219.2	15SF 108
ASME 2500	1/2"	15	P5	264	10.38	264	10.38	11.5	0.45	172	6.8	310	12.2	29.3	64.6	25SRF 103
	3/4"	20	P5	273	10.75	273	10.75	15	0.59	172	6.8	319	12.6	31.8	70.2	25SRF 104
	1"	25	P5	308	12.12	308	12.12	19.5	0.77	234	9.2	369	14.5	52.4	115.6	25SRF 105
	1-1/2"	40	P5	384	15.12	387	15.12	28	1.10	234	9.2	447	17.6	108.5	239.2	25SRF 107
	2"	50	P6	451	17.75	454	17.75	38	1.50	300	11.8	457	18.0	117.5	259.1	25SRF 108

STANDARD BORE

FULL BORE

BFE reserves the right to change designs, dimensions or specifications without notice.

PRODUCT FEATURES:

- Flanged ends acc. to ASME B16.5. • Face to Face acc. to ASME B16.10. • Zero emission. • Hydroformed Bellows • Extension-Bonnet weld acc. to ASME IX.
- Grease nipple for yoke sleeve. • Emergency stuffing box as back sealing.

DESIGN TYPE P4

HANDWHEEL OPERATED & SPIRAL WOUND GASKET BODY-BONNET CONNECTION

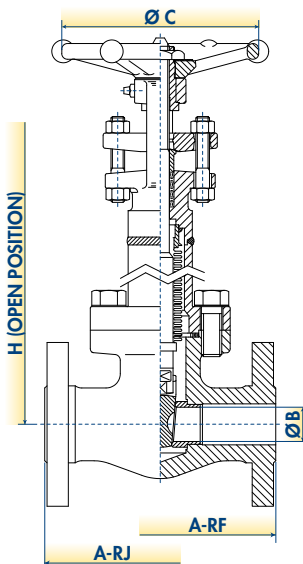

DESIGN TYPE P5

HANDWHEEL OPERATED WITH THRUST BEARINGS & RING JOINT GASKET BODY-BONNET CONNECTION

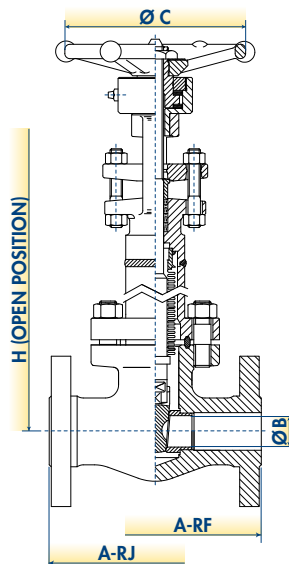

DESIGN TYPE P6

GEAR OPERATED & RING JOINT GASKET BODY-BONNET CONNECTION

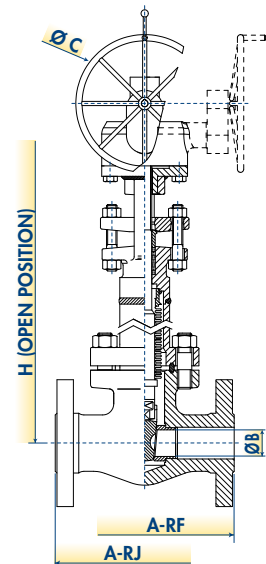

GATE VALVES

WELDED BONNET GATE VALVES BASIC CONFIGURATION THREADED AND SOCKET WELD ENDS



WORKING PRESSURE RATING	SIZE		STANDARD DESIGN TYPE	A		B		C		H		WEIGHT		FIGURE
	NPS	DN		mm	in	mm	in	mm	in	mm	in	kg	lb	
ASME 800	1/2"	15	W1	80	3.15	9.6	0.38	88	3.5	152	6.0	1.6	3.5	WL 103
	3/4"	20	W1	90	3.54	14	0.55	88	3.5	158	6.2	1.8	4.0	WL 104
	1"	25	W1	110	4.33	18	0.71	97	3.8	196	7.7	2.9	6.4	WL 105
	1-1/2"	40	W1	127	5.00	30	1.18	138	5.4	255	10.0	6.1	13.4	WL 107
	2"	50	W1	127	5.00	37.5	1.47	138	5.4	290	11.4	8.2	18.1	WL 108
ASME 1500	1/2"	15	W1	90	3.54	9.6	0.38	88	3.5	153	6.0	2	4.4	9WL 103
	3/4"	20	W1	110	4.33	14	0.55	97	3.8	190	7.5	3.3	7.3	9WL 104
	1"	25	W1	127	5.00	18	0.71	138	5.4	220	8.7	5.3	11.7	9WL 105
	1-1/2"	40	W1	127	5.00	30	1.18	138	5.4	282	11.1	9.8	21.6	9WL 107
	2"	50	W1	210	8.27	37.5	1.47	138	5.4	345	13.6	18.3	40.3	9WL 108
ASME 800	1/4"	6	W1	80	3.15	8	0.31	88	3.5	152	6.0	1.5	3.3	W 101
	3/8"	10	W1	80	3.15	9.6	0.38	88	3.5	152	6.0	1.5	3.3	W 102
	1/2"	15	W1	90	3.54	14	0.55	88	3.5	158	6.2	2	4.4	W 103
	3/4"	20	W1	110	4.33	18	0.71	97	3.8	196	7.7	3.5	7.7	W 104
	1"	25	W1	127	5.00	24	0.94	138	5.4	225	8.9	5	11.0	W 105
	1-1/4"	32	W1	127	5.00	30	1.18	138	5.4	255	10.0	6.5	14.3	W 106
	1-1/2"	40	W1	127	5.00	37.5	1.47	138	5.4	290	11.4	9.5	20.9	W 107
	2"	50	W1	210	8.27	50	1.96	172	6.8	358	14.1	16	35.3	W 108
ASME 1500	1/4"	6	W1	90	3.54	8	0.31	88	3.5	153	6.0	2	4.4	9W 101
	3/8"	10	W1	90	3.54	9.6	0.38	88	3.5	153	6.0	2	4.4	9W 102
	1/2"	15	W1	110	4.33	14	0.55	97	3.8	190	7.5	3.4	7.5	9W 103
	3/4"	20	W1	127	5.00	18	0.71	138	5.4	220	8.7	5.1	11.2	9W 104
	1"	25	W1	127	5.00	24	0.94	138	5.4	250	9.8	7	15.4	9W 105
	1-1/4"	32	W1	127	5.00	30	1.18	138	5.4	282	11.1	10	22.0	9W 106
	1-1/2"	40	W1	210	8.27	37.5	1.47	138	5.4	290	11.4	10.5	23.1	9W 107
	2"	50	W1	210	8.27	50	1.96	172	6.8	345	13.6	19	41.9	9W 108
ASME 2500	1/4"	6	W2	110	4.33	8	0.31	97	3.8	183	7.2	5.2	11.5	25W 101
	3/8"	10	W2	110	4.33	8	0.31	97	3.8	183	7.2	5.3	11.7	25W 102
	1/2"	15	W2	127	5.00	11.5	0.45	138	5.4	214	8.4	5.4	11.9	25W 103
	3/4"	20	W2	127	5.00	15	0.59	138	5.4	244	9.6	7.2	15.9	25W 104
	1"	25	W2	127	5.00	19.5	0.77	138	5.4	276	10.9	9.8	21.6	25W 105
	1-1/4"	32	W2	127	5.00	25	0.98	138	5.4	276	10.9	9.8	21.6	25W 106
	1-1/2"	40	W2	210	8.27	28	1.10	172	6.8	337	13.3	19.5	43.0	25W 107
	2"	50	W2	230	9.06	36	1.41	234	9.2	404	15.9	29	63.9	25W 108
ASME 4500	1/2"	15	W2	127	5.00	7.5	0.30	138	5.4	264	10.4	12	26.5	45W 103
	3/4"	20	W2	127	5.00	11.5	0.45	168	6.6	275	10.8	21	46.3	45W 104
	1"	25	W2	230	9.06	15	0.59	234	9.2	365	14.4	33	72.8	45W 105
	1-1/2"	40	W2	230	9.06	26	1.02	320	12.6	380	15.0	40	88.2	45W 107

STANDARD BORE

FULL BORE

BFE reserves the right to change designs, dimensions or specifications without notice.

PRODUCT FEATURES:

- Socket Weld acc. to ASME B16.11. • Screwed ends (NPT) acc. to ASME B1.20.1. • Butt welding ends acc. to ASME B16.25. • End to End acc. to manufacturer standard. • Body-Bonnet weld acc. to ASME IX.

DESIGN TYPE W1 V-GROOVE SEAL WELD BODY-BONNET CONNECTION

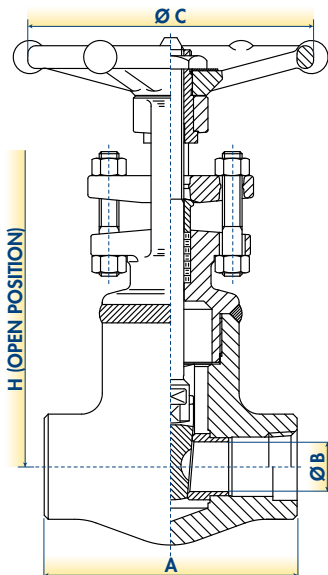

DESIGN TYPE W2 TEE JOINT FILLET WELD BODY-BONNET CONNECTION

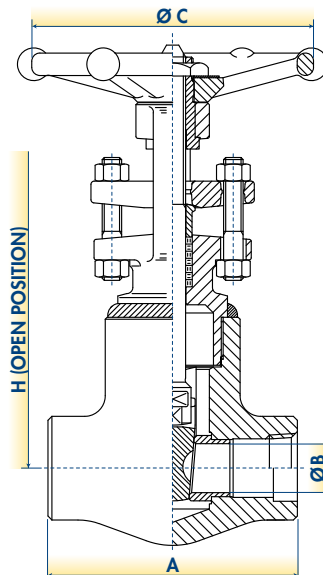

OTHER END CONNECTION TYPES AVAILABLE

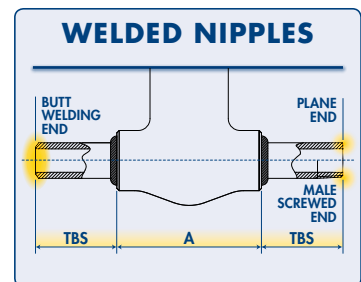
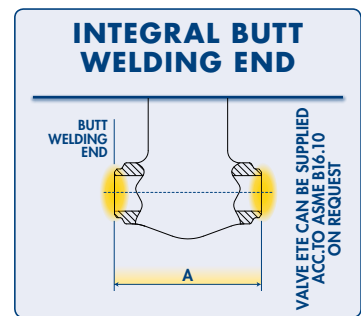

WELDED BONNET GATE VALVES BASIC CONFIGURATION ASME INTEGRAL FLANGED ENDS



WORKING PRESSURE RATING	SIZE		STANDARD DESIGN TYPE	A-RF		A-RJ		B		C		H		WEIGHT		FIGURE
	NPS	DN		mm	in	mm	in	mm	in	mm	in	mm	in	kg	lb	
ASME 150	1/2"	15	W3	108	4.25	N.A.	N.A.	9.6	0.38	88	3.5	152	6.0	4.1	9.0	1HWL 103
	3/4"	20	W3	117	4.62	N.A.	N.A.	14	0.55	88	3.5	158	6.2	5.2	11.4	1HWL 104
	1"	25	W3	127	5.00	140	5.00	18	0.71	97	3.8	196	7.7	7.3	16.0	1HWL 105
	1-1/2"	40	W3	165	6.50	178	6.50	30	1.18	138	5.4	255	10.0	13.4	29.6	1HWL 107
	2"	50	W3	178	7.00	191	7.00	37.5	1.47	138	5.4	290	11.4	18.5	40.7	1HWL 108
ASME 300	1/2"	15	W3	140	5.50	151	5.50	9.6	0.38	88	3.5	152	6.0	5.0	11.1	3HWL 103
	3/4"	20	W3	152	6.00	165	6.00	14	0.55	88	3.5	158	6.2	7.3	16.0	3HWL 104
	1"	25	W3	165	6.50	178	6.50	18	0.71	97	3.8	196	7.7	9.4	20.7	3HWL 105
	1-1/2"	40	W3	190	7.50	203	7.50	30	1.18	138	5.4	255	10.0	18.2	40.1	3HWL 107
	2"	50	W3	216	8.50	232	8.50	37.5	1.47	138	5.4	290	11.4	21.4	47.2	3HWL 108
ASME 600	1/2"	15	W3	165	6.50	163	6.50	9.6	0.38	88	3.5	152	6.0	6.0	13.3	6HWL 103
	3/4"	20	W3	190	7.50	190	7.50	14	0.55	88	3.5	158	6.2	9.8	21.6	6HWL 104
	1"	25	W3	216	8.50	216	8.50	18	0.71	97	3.8	196	7.7	14.0	30.9	6HWL 105
	1-1/2"	40	W3	241	9.50	241	9.50	30	1.18	138	5.4	255	10.0	25.2	55.6	6HWL 107
	2"	50	W3	292	11.50	295	11.50	37.5	1.47	138	5.4	290	11.4	39.2	86.4	6HWL 108
ASME 1500	1/2"	15	W3	216	8.50	216	8.50	9.5	0.37	88	3.5	153	6.0	10.5	23.1	15HWLF 103
	3/4"	20	W3	229	9.00	229	9.00	14	0.55	97	3.8	190	7.5	16.8	37.0	15HWLF 104
	1"	25	W3	254	10.00	254	10.00	18	0.71	138	5.4	220	8.7	21.0	46.3	15HWLF 105
	1-1/2"	40	W3	305	12.00	305	12.00	30	1.18	172	6.8	282	11.1	39.5	87.0	15HWLF 107
	2"	50	W3	368	14.50	371.5	14.50	37.5	1.47	172	6.8	345	13.6	74.2	163.6	15HWLF 108
ASME 150	1/2"	15	W3	108	4.25	N.A.	N.A.	14	0.55	88	3.5	158	6.2	4.5	9.9	1HW 103
	3/4"	20	W3	117	4.62	N.A.	N.A.	18	0.71	97	3.8	196	7.7	6.6	14.5	1HW 104
	1"	25	W3	127	5.00	140	5.00	24	0.94	138	5.4	225	8.9	8.5	18.8	1HW 105
	1-1/2"	40	W3	165	6.50	178	6.50	37.5	1.47	138	5.4	290	11.4	16.0	35.2	1HW 107
	2"	50	W3	178	7.00	191	7.00	48	1.89	172	6.8	358	14.1	25.2	55.6	1HW 108
ASME 300	1/2"	15	W3	140	5.50	151	5.50	14	0.55	88	3.5	158	6.2	5.3	11.7	3HW 103
	3/4"	20	W3	152	6.00	165	6.00	18	0.71	97	3.8	196	7.7	7.8	17.3	3HW 104
	1"	25	W3	165	6.50	178	6.50	24	0.94	138	5.4	225	8.9	9.9	21.9	3HW 105
	1-1/2"	40	W3	190	7.50	203	7.50	37.5	1.47	138	5.4	290	11.4	18.9	41.7	3HW 107
	2"	50	W3	216	8.50	232	8.50	48	1.89	172	6.8	358	14.1	26.6	58.6	3HW 108
ASME 600	1/2"	15	W3	165	6.50	163	6.50	14	0.55	88	3.5	158	6.2	6.0	13.3	6HW 103
	3/4"	20	W3	190	7.50	190	7.50	18	0.71	97	3.8	196	7.7	9.8	21.6	6HW 104
	1"	25	W3	216	8.50	216	8.50	24	0.94	138	5.4	225	8.9	14.0	30.9	6HW 105
	1-1/2"	40	W3	241	9.50	241	9.50	37.5	1.47	138	5.4	290	11.4	25.2	55.6	6HW 107
	2"	50	W3	292	11.50	295	11.50	48	1.89	172	6.8	358	14.1	39.2	86.4	6HW 108
ASME 1500	1/2"	15	W3	216	8.50	216	8.50	14	0.55	97	3.8	190	7.5	11.5	25.3	15HWF 103
	3/4"	20	W3	229	9.00	229	9.00	18	0.71	138	5.4	220	8.7	18.2	40.1	15HWF 104
	1"	25	W3	254	10.00	254	10.00	24	0.94	138	5.4	250	9.8	22.7	50.0	15HWF 105
	1-1/2"	40	W3	305	12.00	305	12.00	37.5	1.47	172	6.8	290	11.4	40.6	89.5	15HWF 107
	2"	50	W3	368	14.50	371.5	14.50	48	1.89	234	9.2	345	13.6	77.0	169.8	15HWF 108
ASME 2500	1/2"	15	W3	264	10.38	264	10.38	11.5	0.45	138	5.4	214	8.4	21.4	47.0	25HWF 103
	3/4"	20	W3	273	10.75	273	10.75	15	0.59	138	5.4	244	9.6	24.6	54.3	25HWF 104
	1"	25	W3	308	12.12	308	12.12	19.5	0.77	172	6.8	276	10.9	40.6	89.5	25HWF 105
	1-1/2"	40	W3	384	15.12	387	15.12	28	1.10	234	9.2	337	13.3	84.0	185.2	25HWF 107
	2"	50	W3	451	17.75	454	17.75	38	1.50	320	12.6	404	15.9	91.0	200.6	25HWF 108

STANDARD BORE

FULL BORE

BFE reserves the right to change designs, dimensions or specifications without notice.

PRODUCT FEATURES:

- Flanged ends acc.to ASME B16.5. • Face to Face acc.to ASME B16.10. • Body-Bonnet weld acc.to ASME IX.

DESIGN TYPE W3

FULL PENETRATION WELD BODY-BONNET CONNECTION

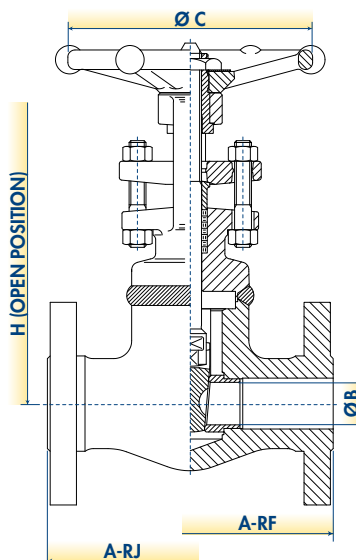

GATE VALVES

WELDED BONNET GATE VALVES CRYOGENIC CONFIGURATION THREADED AND SOCKET WELD ENDS



WORKING PRESSURE RATING	SIZE		STANDARD DESIGN TYPE	A		B		C		H		WEIGHT		FIGURE	
	NPS	DN		mm	in	mm	in	mm	in	mm	in	kg	lb		
ASME 800	1/2"	15	W1	80	3.15	9.6	0.38	88	3.5	406	16.0	2.4	5.3	CWL 103	STANDARD BORE
	3/4"	20	W1	90	3.54	14	0.55	88	3.5	412	16.2	2.7	6.0	CWL 104	
	1"	25	W1	110	4.33	18	0.71	97	3.8	450	17.7	4.4	9.6	CWL 105	
	1-1/2"	40	W1	127	5.00	30	1.18	138	5.4	509	20.0	9.2	20.2	CWL 107	
	2"	50	W1	127	5.00	37.5	1.47	138	5.4	544	21.4	12.3	27.1	CWL 108	
ASME 1500	1/2"	15	W1	90	3.54	9.6	0.38	88	3.5	407	16.0	3.0	6.6	9CWL 103	
	3/4"	20	W1	110	4.33	14	0.55	97	3.8	444	17.5	5.0	10.9	9CWL 104	
	1"	25	W1	127	5.00	18	0.71	138	5.4	474	18.7	8.0	17.5	9CWL 105	
	1-1/2"	40	W1	127	5.00	30	1.18	138	5.4	536	21.1	14.7	32.4	9CWL 107	
	2"	50	W1	210	8.27	37.5	1.47	138	5.4	599	23.6	27.5	60.5	9CWL 108	
ASME 800	1/4"	6	W1	80	3.15	8	0.31	88	3.5	406	16.0	2.3	5.0	CW 101	FULL BORE
	3/8"	10	W1	80	3.15	9.6	0.38	88	3.5	406	16.0	2.3	5.0	CW 102	
	1/2"	15	W1	90	3.54	14	0.55	88	3.5	412	16.2	3.0	6.6	CW 103	
	3/4"	20	W1	110	4.33	18	0.71	97	3.8	450	17.7	5.3	11.6	CW 104	
	1"	25	W1	127	5.00	24	0.94	138	5.4	479	18.9	7.5	16.5	CW 105	
	1-1/4"	32	W1	127	5.00	30	1.18	138	5.4	509	20.0	9.8	21.5	CW 106	
	1-1/2"	40	W1	127	5.00	37.5	1.47	138	5.4	544	21.4	14.3	31.4	CW 107	
	2"	50	W1	210	8.27	50	1.96	172	6.8	612	24.1	24.0	52.9	CW 108	
ASME 1500	1/4"	6	W1	90	3.54	8	0.31	88	3.5	407	16.0	3.0	6.6	9CW 101	
	3/8"	10	W1	90	3.54	9.6	0.38	88	3.5	407	16.0	3.0	6.6	9CW 102	
	1/2"	15	W1	110	4.33	14	0.55	97	3.8	444	17.5	5.1	11.2	9CW 103	
	3/4"	20	W1	127	5.00	18	0.71	138	5.4	474	18.7	7.7	16.9	9CW 104	
	1"	25	W1	127	5.00	24	0.94	138	5.4	504	19.8	10.5	23.1	9CW 105	
	1-1/4"	32	W1	127	5.00	30	1.18	138	5.4	536	21.1	15.0	33.1	9CW 106	
	1-1/2"	40	W1	210	8.27	37.5	1.47	138	5.4	544	21.4	15.8	34.7	9CW 107	
	2"	50	W1	210	8.27	50	1.96	172	6.8	599	23.6	28.5	62.8	9CW 108	
ASME 2500	1/4"	6	W2	110	4.33	8	0.31	97	3.8	437	17.2	7.8	17.2	25CW 101	
	3/8"	10	W2	110	4.33	8	0.31	97	3.8	437	17.2	8.0	17.5	25CW 102	
	1/2"	15	W2	127	5.00	11.5	0.45	138	5.4	468	18.4	8.1	17.9	25CW 103	
	3/4"	20	W2	127	5.00	15	0.59	138	5.4	498	19.6	10.8	23.8	25CW 104	
	1"	25	W2	127	5.00	19.5	0.77	138	5.4	530	20.9	14.7	32.4	25CW 105	
	1-1/4"	32	W2	127	5.00	25	0.98	138	5.4	530	20.9	14.7	32.4	25CW 106	
	1-1/2"	40	W2	210	8.27	28	1.10	172	6.8	591	23.3	29.3	64.5	25CW 107	
	2"	50	W2	230	9.06	36	1.41	234	9.2	658	25.9	43.5	95.9	25CW 108	
ASME 4500	1/2"	15	W2	127	5.00	7.5	0.30	138	5.4	518	20.4	18.0	39.7	45CW 103	
	3/4"	20	W2	127	5.00	11.5	0.45	168	6.6	529	20.8	31.5	69.4	45CW 104	
	1"	25	W2	230	9.06	15	0.59	234	9.2	619	24.4	49.5	109.1	45CW 105	
	1-1/2"	40	W2	230	9.06	26	1.02	320	12.6	634	25.0	60.0	132.3	45CW 107	

BPE reserves the right to change designs, dimensions or specifications without notice.

PRODUCT FEATURES:

- Socket Weld acc.to ASME B16.11. • Screwed ends (NPT) acc.to ASME B1.20.1. • Butt welding ends acc.to ASME B16.25. • End to End acc.to manufacturer standard. • Cryogenic design acc.to BS 6364. • Body-Bonnet weld acc.to ASME IX. • Body Cavity Vent Hole.

DESIGN TYPE W1 V-GROOVE SEAL WELD BODY-BONNET CONNECTION

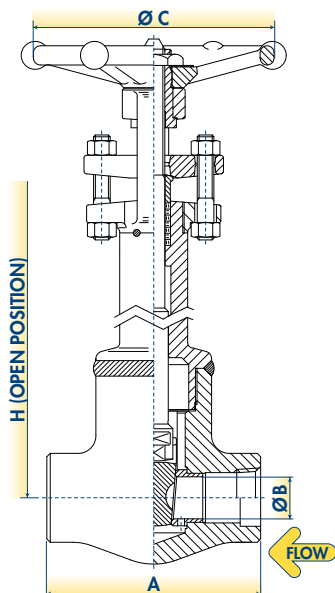

DESIGN TYPE W2 TEE JOINT FILLET WELD BODY-BONNET CONNECTION

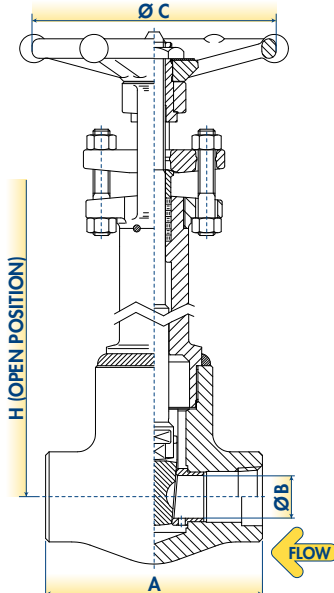

OTHER END CONNECTION TYPES AVAILABLE

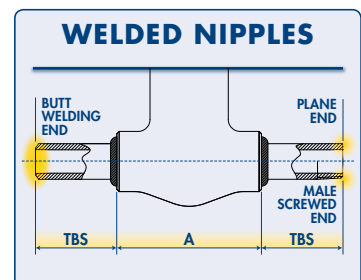
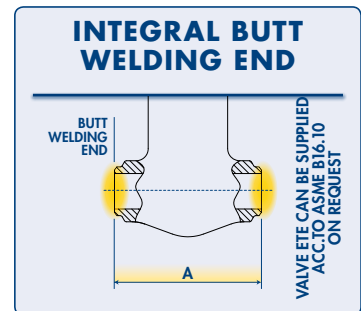

WELDED BONNET GATE VALVES CRYOGENIC CONFIGURATION ASME INTEGRAL FLANGED ENDS



WORKING PRESSURE RATING	SIZE		STANDARD DESIGN TYPE	A-RF		A-RJ		B		C		H		WEIGHT		FIGURE
	NPS	DN		mm	in	mm	in	mm	in	mm	in	mm	in	kg	lb	
ASME 150	1/2"	15	W3	108	4.25	N.A.	N.A.	9.6	0.38	88	3.5	406	16.0	5.9	13.0	1CHWL 103
	3/4"	20	W3	117	4.62	N.A.	N.A.	14	0.55	88	3.5	412	16.2	7.5	16.6	1CHWL 104
	1"	25	W3	127	5.00	140	5.00	18	0.71	97	3.8	450	17.7	10.6	23.3	1CHWL 105
	1-1/2"	40	W3	165	6.50	178	6.50	30	1.18	138	5.4	509	20.0	19.5	43.0	1CHWL 107
	2"	50	W3	178	7.00	191	7.00	37.5	1.47	138	5.4	544	21.4	26.8	59.1	1CHWL 108
ASME 300	1/2"	15	W3	140	5.50	151	5.50	9.6	0.38	88	3.5	406	16.0	7.3	16.1	3CHWL 103
	3/4"	20	W3	152	6.00	165	6.00	14	0.55	88	3.5	412	16.2	10.6	23.3	3CHWL 104
	1"	25	W3	165	6.50	178	6.50	18	0.71	97	3.8	450	17.7	13.6	30.0	3CHWL 105
	1-1/2"	40	W3	190	7.50	203	7.50	30	1.18	138	5.4	509	20.0	26.4	58.2	3CHWL 107
	2"	50	W3	216	8.50	232	8.50	37.5	1.47	138	5.4	544	21.4	31.1	68.5	3CHWL 108
ASME 600	1/2"	15	W3	165	6.50	163	6.50	9.6	0.38	88	3.5	406	16.0	8.7	19.2	6CHWL 103
	3/4"	20	W3	190	7.50	190	7.50	14	0.55	88	3.5	412	16.2	14.2	31.3	6CHWL 104
	1"	25	W3	216	8.50	216	8.50	18	0.71	97	3.8	450	17.7	20.3	44.8	6CHWL 105
	1-1/2"	40	W3	241	9.50	241	9.50	30	1.18	138	5.4	509	20.0	36.5	80.6	6CHWL 107
	2"	50	W3	292	11.50	295	11.50	37.5	1.47	138	5.4	544	21.4	56.8	125.3	6CHWL 108
ASME 1500	1/2"	15	W3	216	8.50	216	8.50	9.5	0.37	88	3.5	407	16.0	15.2	33.6	15CHWLF 103
	3/4"	20	W3	229	9.00	229	9.00	14	0.55	97	3.8	444	17.5	24.4	53.7	15CHWLF 104
	1"	25	W3	254	10.00	254	10.00	18	0.71	138	5.4	474	18.7	30.5	67.1	15CHWLF 105
	1-1/2"	40	W3	305	12.00	305	12.00	30	1.18	172	6.8	536	21.1	57.2	126.2	15CHWLF 107
	2"	50	W3	368	14.50	371.5	14.50	37.5	1.47	172	6.8	599	23.6	107.6	237.2	15CHWLF 108
ASME 150	1/2"	15	W3	108	4.25	N.A.	N.A.	14	0.55	88	3.5	412	16.2	6.5	14.3	1CHW 103
	3/4"	20	W3	117	4.62	N.A.	N.A.	18	0.71	97	3.8	450	17.7	9.5	21.0	1CHW 104
	1"	25	W3	127	5.00	140	5.00	24	0.94	138	5.4	479	18.9	12.4	27.3	1CHW 105
	1-1/2"	40	W3	165	6.50	178	6.50	37.5	1.47	138	5.4	544	21.4	23.1	51.0	1CHW 107
	2"	50	W3	178	7.00	191	7.00	48	1.89	172	6.8	612	24.1	36.5	80.6	1CHW 108
ASME 300	1/2"	15	W3	140	5.50	151	5.50	14	0.55	88	3.5	412	16.2	7.7	17.0	3CHW 103
	3/4"	20	W3	152	6.00	165	6.00	18	0.71	97	3.8	450	17.7	11.4	25.1	3CHW 104
	1"	25	W3	165	6.50	178	6.50	24	0.94	138	5.4	479	18.9	14.4	31.8	3CHW 105
	1-1/2"	40	W3	190	7.50	203	7.50	37.5	1.47	138	5.4	544	21.4	27.4	60.4	3CHW 107
	2"	50	W3	216	8.50	232	8.50	48	1.89	172	6.8	612	24.1	38.6	85.0	3CHW 108
ASME 600	1/2"	15	W3	165	6.50	163	6.50	14	0.55	88	3.5	412	16.2	8.7	19.2	6CHW 103
	3/4"	20	W3	190	7.50	190	7.50	18	0.71	97	3.8	450	17.7	14.2	31.3	6CHW 104
	1"	25	W3	216	8.50	216	8.50	24	0.94	138	5.4	479	18.9	20.3	44.8	6CHW 105
	1-1/2"	40	W3	241	9.50	241	9.50	37.5	1.47	138	5.4	544	21.4	36.5	80.6	6CHW 107
	2"	50	W3	292	11.50	295	11.50	48	1.89	172	6.8	612	24.1	56.8	125.3	6CHW 108
ASME 1500	1/2"	15	W3	216	8.50	216	8.50	14	0.55	97	3.8	444	17.5	16.6	36.7	15CHWF 103
	3/4"	20	W3	229	9.00	229	9.00	18	0.71	138	5.4	474	18.7	26.4	58.2	15CHWF 104
	1"	25	W3	254	10.00	254	10.00	24	0.94	138	5.4	504	19.8	32.9	72.5	15CHWF 105
	1-1/2"	40	W3	305	12.00	305	12.00	37.5	1.47	172	6.8	544	21.4	58.9	129.8	15CHWF 107
	2"	50	W3	368	14.50	371.5	14.50	48	1.89	234	9.2	599	23.6	111.7	246.1	15CHWF 108
ASME 2500	1/2"	15	W3	264	10.38	264	10.38	11.5	0.45	138	5.4	468	18.4	32.9	72.5	25CHWF 103
	3/4"	20	W3	273	10.75	273	10.75	15	0.59	138	5.4	498	19.6	35.7	78.8	25CHWF 104
	1"	25	W3	308	12.12	308	12.12	19.5	0.77	172	6.8	530	20.9	58.9	129.8	25CHWF 105
	1-1/2"	40	W3	384	15.12	387	15.12	28	1.10	234	9.2	591	23.3	121.8	268.5	25CHWF 107
	2"	50	W3	451	17.75	454	17.75	38	1.50	320	12.6	658	25.9	132.0	290.9	25CHWF 108

STANDARD BORE

FULL BORE

BFE reserves the right to change designs, dimensions or specifications without notice.

PRODUCT FEATURES:

- Flanged ends acc.to ASME B16.5. • Face to Face acc.to ASME B16.10. • Cryogenic design acc.to BS 6364. • Body-Bonnet weld acc.to ASME IX. • Body Cavity Vent Hole.

DESIGN TYPE W3

FULL PENETRATION WELD BODY-BONNET CONNECTION

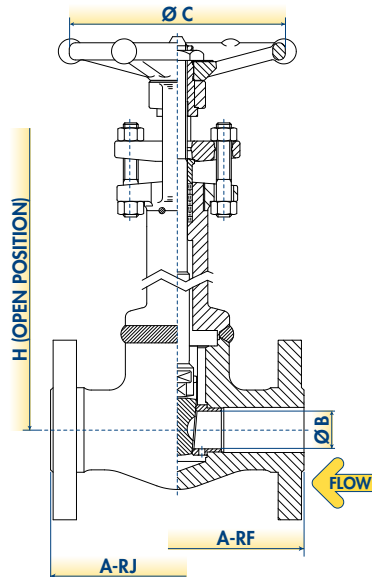

GATE VALVES

WELDED BONNET GATE VALVES BELLOW SEAL CONFIGURATION THREADED AND SOCKET WELD ENDS



WORKING PRESSURE RATING	SIZE		STANDARD DESIGN TYPE	A		B		C		H		WEIGHT		FIGURE
	NPS	DN		mm	in	mm	in	mm	in	mm	in	kg	lb	
ASME 800	1/2"	15	P1	80	3.15	9.6	0.38	88	3.5	230	9.1	2.1	4.6	SHWL 103
	3/4"	20	P1	90	3.54	14	0.55	88	3.5	234	9.2	2.4	5.3	SHWL 104
	1"	25	P1	110	4.33	18	0.71	97	3.8	285	11.2	3.9	8.6	SHWL 105
	1-1/2"	40	P1	127	5.00	30	1.18	138	5.4	370	14.6	8.6	19.0	SHWL 107
	2"	50	P1	127	5.00	37.5	1.47	138	5.4	435	17.1	11	24.3	SHWL 108
ASME 1500	1/2"	15	P1	90	3.54	9.6	0.38	138	5.4	238	9.4	2.8	6.2	9SHWL 103
	3/4"	20	P1	110	4.33	14	0.55	138	5.4	293	11.5	4.6	10.1	9SHWL 104
	1"	25	P1	127	5.00	18	0.71	138	5.4	343	13.5	6.5	14.3	9SHWL 105
	1-1/2"	40	P1	127	5.00	30	1.18	234	9.2	450	17.7	9	19.8	9SHWL 107
	2"	50	P1	210	8.27	37.5	1.47	234	9.2	588	23.1	22	48.5	9SHWL 108
ASME 800	1/4"	6	P1	80	3.15	8	0.31	88	3.5	230	9.1	2.3	5.1	SHW 101
	3/8"	10	P1	80	3.15	9.6	0.38	88	3.5	230	9.1	2.3	5.1	SHW 102
	1/2"	15	P1	90	3.54	14	0.55	88	3.5	234	9.2	2.5	5.5	SHW 103
	3/4"	20	P1	110	4.33	18	0.71	97	3.8	285	11.2	3.8	8.4	SHW 104
	1"	25	P1	127	5.00	24	0.94	138	5.4	325	12.8	6.2	13.7	SHW 105
	1-1/4"	32	P1	127	5.00	30	1.18	138	5.4	370	14.6	8.4	18.5	SHW 106
	1-1/2"	40	P1	127	5.00	37.5	1.47	138	5.4	435	17.1	11.2	24.7	SHW 107
	2"	50	P1	210	8.27	50	1.96	172	6.8	530	20.9	20	44.1	SHW 108
ASME 1500	1/2"	15	P1	110	4.33	14	0.55	138	5.4	293	11.5	4.5	9.9	9SHW 103
	3/4"	20	P1	127	5.00	18	0.71	138	5.4	343	13.5	6.5	14.3	9SHW 104
	1"	25	P1	127	5.00	24	0.94	172	6.8	388	15.3	8.3	18.3	9SHW 105
	1-1/2"	40	P1	210	8.27	37.5	1.47	234	9.2	588	23.1	22	48.5	9SHW 107
	2"	50	P1	210	8.27	48	1.89	320	12.6	590	23.2	37	81.6	9SHW 108
ASME 2500	1/2"	15	P2	127	5.00	11.5	0.45	172	6.8	430	16.9	6.5	14.3	25SHW 103
	3/4"	20	P2	127	5.00	15	0.59	172	6.8	450	17.7	6.5	14.3	25SHW 104
	1"	25	P2	127	5.00	19.5	0.77	234	9.2	510	20.1	16	35.3	25SHW 105
	1-1/2"	40	P2	210	8.27	28	1.10	234	9.2	630	24.8	29	63.9	25SHW 107
	2"	50	P3	230	9.06	35	1.38	300	11.8	880	34.6	45	99.2	25SHW 108

STANDARD BORE

FULL BORE

BFE reserves the right to change designs, dimensions or specifications without notice.

PRODUCT FEATURES:

- Socket Weld acc.to ASME B16.11. • Screwed ends (NPT) acc.to ASME B1.20.1. • Butt welding ends acc.to ASME B16.25. • End to End acc.to manufacturer standard. • Zero emission. • Hydroformed Bellows
- Welds acc.to ASME IX. • Grease nipple for yoke sleeve. • Emergency stuffing box as back sealing.

DESIGN TYPE P1 HANDWHEEL OPERATED

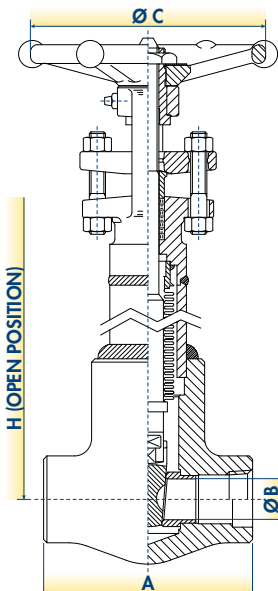

DESIGN TYPE P2 HANDWHEEL OPERATED WITH THRUST BEARINGS

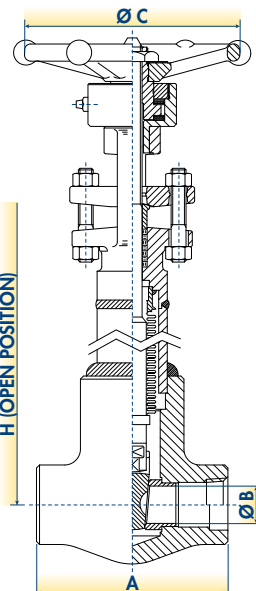

DESIGN TYPE P3 GEAR OPERATED

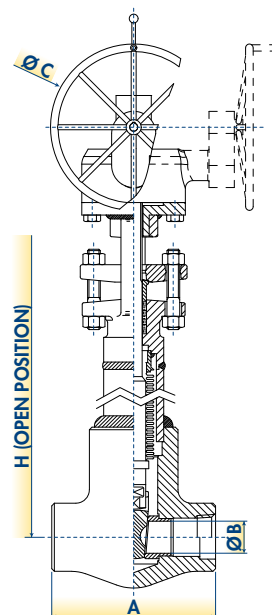

OTHER END CONNECTION TYPES AVAILABLE

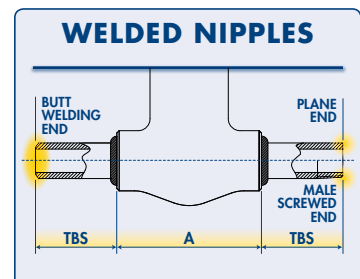
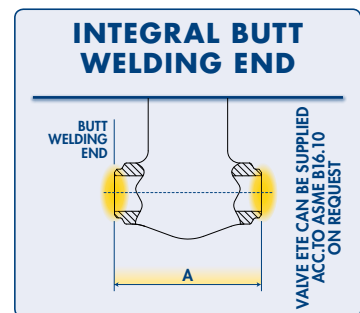

WELDED BONNET GATE VALVES BELLOW SEAL CONFIGURATION ASME INTEGRAL FLANGED ENDS



WORKING PRESSURE RATING	SIZE		STANDARD DESIGN TYPE	A-RF		A-RJ		B		C		H		WEIGHT		FIGURE
	NPS	DN		mm	in	mm	in	mm	in	mm	in	mm	in	kg	lb	
ASME 150	1/2"	15	P1	108	4.25	N.A.	N.A.	9.6	0.38	88	3.5	193	7.6	4.6	10.2	1SHWL 103
	3/4"	20	P1	117	4.62	N.A.	N.A.	14	0.55	88	3.5	200	7.9	5.9	13.1	1SHWL 104
	1"	25	P1	127	5.00	140	5.50	18	0.71	97	3.8	233	9.2	8.3	18.3	1SHWL 105
	1-1/2"	40	P1	165	6.50	178	7.00	30	1.18	138	5.4	281	11.0	15.4	33.9	1SHWL 107
	2"	50	P1	178	7.00	191	7.50	37.5	1.47	138	5.4	319	12.6	21.1	46.6	1SHWL 108
ASME 300	1/2"	15	P1	140	5.50	151	5.94	9.6	0.38	88	3.5	193	7.6	5.8	12.7	3SHWL 103
	3/4"	20	P1	152	6.00	165	6.50	14	0.55	88	3.5	200	7.9	8.3	18.3	3SHWL 104
	1"	25	P1	165	6.50	178	7.00	18	0.71	97	3.8	233	9.2	10.7	23.6	3SHWL 105
	1-1/2"	40	P1	190	7.50	203	8.00	30	1.18	138	5.4	264	10.4	20.8	45.9	3SHWL 107
	2"	50	P1	216	8.50	232	9.12	37.5	1.47	138	5.4	319	12.6	24.5	54.0	3SHWL 108
ASME 600	1/2"	15	P1	165	6.50	163	6.44	9.6	0.38	88	3.5	175	6.9	6.9	15.2	6SHWL 103
	3/4"	20	P1	190	7.50	190	7.50	14	0.55	88	3.5	204	8.0	11.2	24.7	6SHWL 104
	1"	25	P1	216	8.50	216	8.50	18	0.71	97	3.8	237	9.3	16.0	35.3	6SHWL 105
	1-1/2"	40	P1	241	9.50	241	9.50	30	1.18	138	5.4	281	11.0	28.8	63.5	6SHWL 107
	2"	50	P1	292	11.50	295	11.62	37.5	1.47	138	5.4	336	13.2	44.8	98.8	6SHWL 108
ASME 1500	1/2"	15	P1	216	8.50	216	8.50	9.5	0.37	138	5.4	204	8.0	12.0	26.5	15SHWLF 103
	3/4"	20	P1	229	9.00	229	9.00	14	0.55	138	5.4	237	9.3	19.2	42.3	15SHWLF 104
	1"	25	P1	254	10.00	254	10.00	18	0.71	138	5.4	270	10.6	24.0	52.9	15SHWLF 105
	1-1/2"	40	P1	305	12.00	305	12.00	30	1.18	234	9.2	325	12.8	45.1	99.5	15SHWLF 107
	2"	50	P1	368	14.50	371.5	14.62	37.5	1.47	234	9.2	363	14.3	84.8	187.0	15SHWLF 108
ASME 150	1/2"	15	P1	108	4.25	N.A.	N.A.	14	0.55	88	3.5	193	7.6	5.1	11.3	1SHW 103
	3/4"	20	P1	117	4.62	N.A.	N.A.	18	0.71	97	3.8	231	9.1	7.5	16.6	1SHW 104
	1"	25	P1	127	5.00	140	5.50	24	0.94	138	5.4	253	10.0	9.8	21.5	1SHW 105
	1-1/2"	40	P1	165	6.50	178	7.00	37.5	1.47	138	5.4	319	12.6	18.2	40.2	1SHW 107
	2"	50	P1	178	7.00	191	7.50	48	1.89	172	6.8	374	14.7	28.8	63.5	1SHW 108
ASME 300	1/2"	15	P1	140	5.50	151	5.94	14	0.55	88	3.5	193	7.6	6.1	13.4	3SHW 103
	3/4"	20	P1	152	6.00	165	6.50	18	0.71	97	3.8	231	9.1	9.0	19.8	3SHW 104
	1"	25	P1	165	6.50	178	7.00	24	0.94	138	5.4	253	10.0	11.4	25.0	3SHW 105
	1-1/2"	40	P1	190	7.50	203	8.00	37.5	1.47	138	5.4	319	12.6	21.6	47.6	3SHW 107
	2"	50	P1	216	8.50	232	9.12	48	1.89	172	6.8	374	14.7	30.4	67.0	3SHW 108
ASME 600	1/2"	15	P1	165	6.50	163	6.44	14	0.55	88	3.5	193	7.6	6.9	15.2	6SHW 103
	3/4"	20	P1	190	7.50	190	7.50	18	0.71	97	3.8	237	9.3	11.2	24.7	6SHW 104
	1"	25	P1	216	8.50	216	8.50	24	0.94	138	5.4	264	10.4	16.0	35.3	6SHW 105
	1-1/2"	40	P1	241	9.50	241	9.50	37.5	1.47	138	5.4	325	12.8	28.8	63.5	6SHW 107
	2"	50	P1	292	11.50	295	11.62	48	1.89	172	6.8	396	15.6	44.8	98.8	6SHW 108
ASME 1500	1/2"	15	P1	216	8.50	216	8.50	14	0.55	138	5.4	237	9.3	13.1	28.9	15SHWF 103
	3/4"	20	P1	229	9.00	229	9.00	18	0.71	138	5.4	275	10.8	20.8	45.9	15SHWF 104
	1"	25	P1	254	10.00	254	10.00	24	0.94	172	6.8	297	11.7	25.9	57.1	15SHWF 105
	1-1/2"	40	P1	305	12.00	305	12.00	37.5	1.47	234	9.2	385	15.2	46.4	102.3	15SHWF 107
	2"	50	P1	368	14.50	371.5	14.62	48	1.89	320	12.6	490	19.3	88.0	194.0	15SHWF 108
ASME 2500	1/2"	15	P2	264	10.38	264	10.38	11.5	0.45	172	6.8	310	12.2	25.9	57.1	25SHWF 103
	3/4"	20	P2	273	10.75	273	10.75	15	0.59	172	6.8	319	12.6	28.2	62.1	25SHWF 104
	1"	25	P2	308	12.12	308	12.12	19.5	0.77	234	9.2	369	14.5	46.4	102.3	25SHWF 105
	1-1/2"	40	P2	384	15.12	387	15.24	28	1.10	234	9.2	447	17.6	96.0	211.6	25SHWF 107
	2"	50	P3	451	17.75	454	17.87	38	1.50	300	11.8	457	18.0	104.0	229.3	25SHWF 108

STANDARD BORE

FULL BORE

BFE reserves the right to change designs, dimensions or specifications without notice.

PRODUCT FEATURES:

- Flanged ends acc.to ASME B16.5. • Face to Face acc.to ASME B16.10. • Zero emission. • Hydroformed Bellows. • Welds acc.to ASME IX. • Grease nipple for yoke sleeve. • Emergency stuffing box as back sealing.

**DESIGN TYPE P1
HANDWHEEL OPERATED**

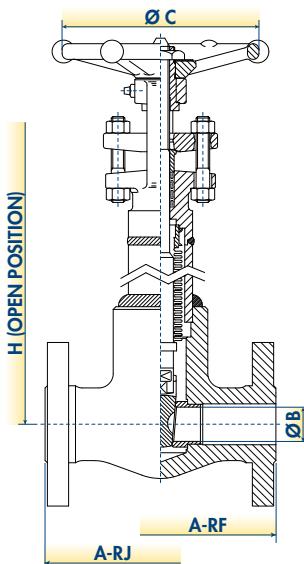

**DESIGN TYPE P2
HANDWHEEL OPERATED WITH THRUST BEARINGS**

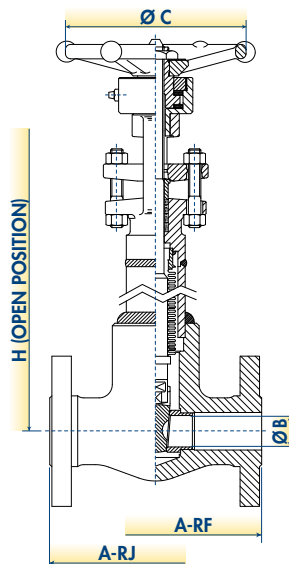

**DESIGN TYPE P3
GEAR OPERATED**

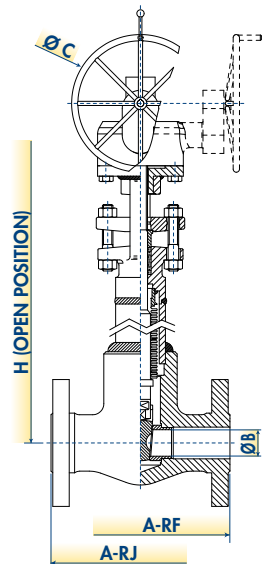

GATE VALVES

BOLTED BONNET GATE VALVES INTEGRAL REINFORCED EXTENDED BODY CONFIGURATION VALVOLET AND LIP ENDS VALVES

WORKING PRESSURE RATING	SIZE		STANDARD DESIGN TYPE	A		B		C		H		D1		D2		D3		L1		L2		WEIGHT		FIGURE LIP	FIGURE VALVOLET	STANDARD BORE
	NPS	DN		mm	in	mm	in	mm	in	mm	in	mm	in	mm	in	mm	in	mm	in	mm	in	kg	lb			
ASME 800	1/2"	15	E1	207	8.15	9.6	0.38	88	3.5	152	6.0	17.5	0.69	22	0.9	N.A.	N.A.	167	6.6	4	0.16	2.6	5.7	VLL 103	VL 103	STANDARD BORE
	3/4"	20	E1	218.5	8.60	14	0.55	88	3.5	158	6.2	22	0.87	30	1.2	N.A.	N.A.	173	6.8	4.8	0.19	3.1	6.8	VLL 104	VL 104	
	1"	25	E1	244.5	9.63	18	0.71	97	3.8	196	7.7	28.5	1.12	36.5	1.4	N.A.	N.A.	190	7.5	4.8	0.19	5.1	11.2	VLL 105	VL 105	
	1-1/2"	40	E1	263.5	10.37	30	1.18	138	5.4	255	10.0	41	1.61	50.5	2.0	N.A.	N.A.	200	7.9	6.3	0.25	9.5	20.9	VLL 107	VL 107	
	2"	50	E1	267.5	10.53	36.6	1.44	138	5.4	290	11.4	46	1.81	65	2.6	N.A.	N.A.	204	8.0	8	0.31	13	28.7	VLL 108	VL 108	
ASME 1500	1/2"	15	E1	218.5	8.60	9.6	0.38	88	3.5	153	6.0	17.5	0.69	30	1.2	N.A.	N.A.	173	6.8	4	0.16	3.6	7.9	9VLL 103	9VL 103	
	3/4"	20	E1	244.5	9.63	14	0.55	97	3.8	190	7.5	22	0.87	36.5	1.4	N.A.	N.A.	190	7.5	4.8	0.19	5.6	12.3	9VLL 104	9VL 104	
	1"	25	E1	263.5	10.37	18	0.71	138	5.4	220	8.7	28.5	1.12	50.5	2.0	N.A.	N.A.	200	7.9	4.8	0.19	10.5	23.1	9VLL 105	9VL 105	
	1-1/2"	40	E1	267.5	10.53	30	1.18	138	5.4	282	11.1	41	1.61	65	2.6	N.A.	N.A.	204	8.0	6.3	0.25	14.5	32.0	9VLL 107	9VL 107	

PRODUCT FEATURES:

- Socket Weld acc.to ASME B16.11. • Screwed ends (NPT) acc.to ASME B1.20.1. • Butt welding ends acc.to ASME B16.25. • End to End acc.to manufacturer standard.

BOLTED BONNET GATE VALVES EXTENDED BODY CONFIGURATION THREADED AND WELDING ENDS VALVES

WORKING PRESSURE RATING	SIZE		STANDARD DESIGN TYPE	A		B		C		H		D1		D2		D3		L1		WEIGHT		FIGURE SOCKET	FIGURE WELDING	FIGURE MALE THREADED	STANDARD BORE
	NPS	DN		mm	in	mm	in	mm	in	mm	in	mm	in	mm	in	mm	in	mm	in	kg	lb				
ASME 800	1/2"	15	E2	141.5	5.57	9.6	0.38	88	3.5	152	6.0	21.3	0.8	13	0.5	23	0.91	102	4.0	2.4	5.3	MLT 103	MLB 103	MLF 103	STANDARD BORE
	3/4"	20	E2	146.5	5.77	14	0.55	88	3.5	158	6.2	26.7	1.1	16	0.6	28	1.10	102	4.0	2.6	5.7	MLT 104	MLB 104	MLF 104	
	1"	25	E2	166	6.54	18	0.71	97	3.8	196	7.7	33.4	1.3	21	0.8	36	1.42	111	4.4	4.2	9.3	MLT 105	MLB 105	MLF 105	
	1-1/2"	40	E2	190.5	7.50	30	1.18	138	5.4	255	10.0	48.3	1.9	34	1.3	52	2.05	127	5.0	8.1	17.9	MLT 107	MLB 107	MLF 107	
	2"	50	E2	216	8.50	36.6	1.44	138	5.4	290	11.4	60.3	2.4	42	1.7	62	2.44	153	6.0	11.8	26.0	MLT 108	MLB 108	MLF 108	
ASME 1500	1/2"	15	E2	146.5	5.77	9.6	0.38	88	3.5	153	6.0	21.3	0.8	13	0.5	23	0.91	102	4.0	2.6	5.7	9MLT 103	9MLB 103	9MLF 103	
	3/4"	20	E2	166	6.54	14	0.55	97	3.8	190	7.5	26.7	1.1	16	0.6	28	1.10	111	4.4	4.6	10.1	9MLT 104	9MLB 104	9MLF 104	
	1"	25	E2	190.5	7.50	18	0.71	138	5.4	220	8.7	33.4	1.3	21	0.8	36	1.42	127	5.0	9.1	20.1	9MLT 105	9MLB 105	9MLF 105	
	1-1/2"	40	E2	216	8.50	30	1.18	138	5.4	282	11.1	48.3	1.9	34	1.3	52	2.05	153	6.0	13	28.7	9MLT 107	9MLB 107	9MLF 107	

PRODUCT FEATURES:

- Socket Weld acc.to ASME B16.11. • Screwed ends (NPT) acc.to ASME B1.20.1. • Butt welding ends acc.to ASME B16.25. • End to End acc.to manufacturer standard.

DESIGN TYPE E1

INTEGRAL REINFORCED EXTENDED BODY SPIRAL WOUND BODY-BONNET CONNECTION

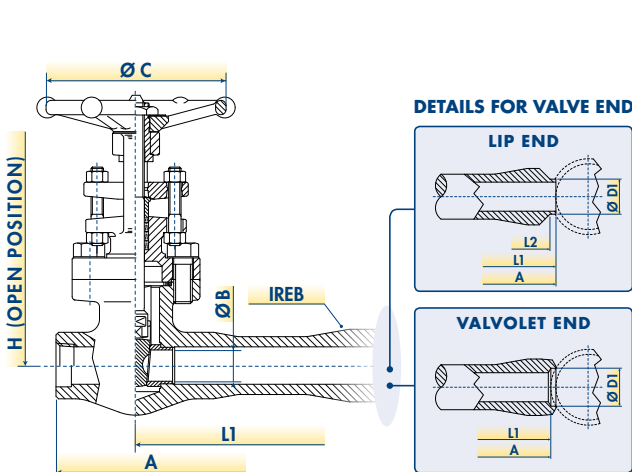

DESIGN TYPE E2

EXTENDED BODY SPIRAL WOUND BODY-BONNET CONNECTION

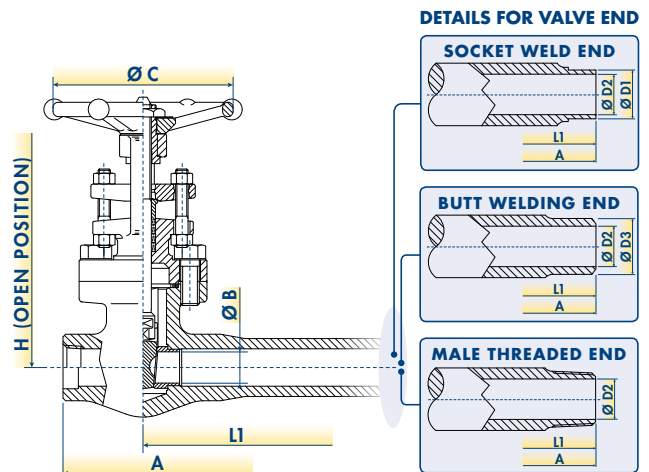

BFE reserves the right to change designs, dimensions or specifications without notice.

WELDED BONNET GATE VALVES INTEGRAL REINFORCED EXTENDED BODY CONFIGURATION VALVOLET AND LIP ENDS VALVES



SPL

SPL

WORKING PRESSURE RATING	SIZE		STANDARD DESIGN TYPE	A		B		C		H		D1		D2		D3		L1		L2		WEIGHT		FIGURE LIP	FIGURE VALVOLET	STANDARD BORE
	NPS	DN		mm	in	mm	in	mm	in	mm	in	mm	in	mm	in	mm	in	mm	in	mm	in	kg	lb			
ASME 800	1/2"	15	E3	207	8.15	9.6	0.38	88	3.5	152	6.0	17.5	0.69	22	0.9	N.A.	N.A.	167	6.6	4	0.16	2.3	5.1	VOL 103	VOLL 103	
	3/4"	20	E3	218.5	8.60	14	0.55	88	3.5	158	6.2	22	0.87	30	1.2	N.A.	N.A.	173	6.8	4.8	0.19	2.9	6.4	VOL 104	VOLL 104	
	1"	25	E3	244.5	9.63	18	0.71	97	3.8	196	7.7	28.5	1.12	36.5	1.4	N.A.	N.A.	190	7.5	4.8	0.19	4.3	9.5	VOL 105	VOLL 105	
	1-1/2"	40	E3	263.5	10.37	30	1.18	138	5.4	255	10.0	41	1.61	50.5	2.0	N.A.	N.A.	200	7.9	6.3	0.25	8.8	19.4	VOL 107	VOLL 107	
	2"	50	E3	267.5	10.53	36.6	1.44	138	5.4	290	11.4	46	1.81	65	2.6	N.A.	N.A.	204	8.0	8	0.31	11.7	25.8	VOL 108	VOLL 108	
ASME 1500	1/2"	15	E3	218.5	8.60	9.6	0.38	88	3.5	153	6.0	17.5	0.69	30	1.2	N.A.	N.A.	173	6.8	4	0.16	2.9	6.4	9VOL 103	9VOLL 103	
	3/4"	20	E3	244.5	9.63	14	0.55	97	3.8	190	7.5	22	0.87	36.5	1.4	N.A.	N.A.	190	7.5	4.8	0.19	4.7	10.4	9VOL 104	9VOLL 104	
	1"	25	E3	263.5	10.37	18	0.71	138	5.4	220	8.7	28.5	1.12	50.5	2.0	N.A.	N.A.	200	7.9	4.8	0.19	9	19.8	9VOL 105	9VOLL 105	
	1-1/2"	40	E3	267.5	10.53	30	1.18	138	5.4	282	11.1	41	1.61	65	2.6	N.A.	N.A.	204	8.0	6.3	0.25	12.5	27.6	9VOL 107	9VOLL 107	

PRODUCT FEATURES:

- Socket Weld acc.to ASME B16.11. • Screwed ends (NPT) acc.to ASME B1.20.1. • Butt welding ends acc.to ASME B16.25. • End to End acc.to manufacturer standard. • Body-Bonnet weld acc.to ASME IX.

BFE reserves the right to change designs, dimensions or specifications without notice.

WELDED BONNET GATE VALVES EXTENDED BODY CONFIGURATION THREADED AND WELDING ENDS VALVES



SPL



WORKING PRESSURE RATING	SIZE		STANDARD DESIGN TYPE	A		B		C		H		D1		D2		D3		L1		WEIGHT		FIGURE SOCKET	FIGURE WELDING	FIGURE MALE THREADED	STANDARD BORE
	NPS	DN		mm	in	mm	in	mm	in	mm	in	mm	in	mm	in	mm	in	kg	lb						
ASME 800	1/2"	15	E4	141.5	5.57	9.6	0.38	88	3.5	152	6.0	21.3	0.8	13	0.5	23	0.91	102	4.0	1.7	3.7	MFLT 103	MFLB 103	MFLF 103	
	3/4"	20	E4	146.5	5.77	14	0.55	88	3.5	158	6.2	26.7	1.1	16	0.6	28	1.10	102	4.0	2.1	4.6	MFLT 104	MFLB 104	MFLF 104	
	1"	25	E4	166	6.54	18	0.71	97	3.8	196	7.7	33.4	1.3	21	0.8	36	1.42	111	4.4	3.2	7.1	MFLT 105	MFLB 105	MFLF 105	
	1-1/2"	40	E4	190.5	7.50	30	1.18	138	5.4	255	10.0	48.3	1.9	34	1.3	52	2.05	127	5.0	7.2	15.9	MFLT 107	MFLB 107	MFLF 107	
	2"	50	E4	216	8.50	36.6	1.44	138	5.4	290	11.4	60.3	2.4	42	1.7	62	2.44	153	6.0	10.3	22.7	MFLT 108	MFLB 108	MFLF 108	
ASME 1500	1/2"	15	E4	146.5	5.77	9.6	0.38	88	3.5	153	6.0	21.3	0.8	13	0.5	23	0.91	102	4.0	2.1	4.6	9MFLT 103	9MFLB 103	9MFLF 103	
	3/4"	20	E4	166	6.54	14	0.55	97	3.8	190	7.5	26.7	1.1	16	0.6	28	1.10	111	4.4	3.8	8.4	9MFLT 104	9MFLB 104	9MFLF 104	
	1"	25	E4	190.5	7.50	18	0.71	138	5.4	220	8.7	33.4	1.3	21	0.8	36	1.42	127	5.0	8.1	17.9	9MFLT 105	9MFLB 105	9MFLF 105	
	1-1/2"	40	E4	216	8.50	30	1.18	138	5.4	282	11.1	48.3	1.9	34	1.3	52	2.05	153	6.0	12	26.5	9MFLT 107	9MFLB 107	9MFLF 107	

PRODUCT FEATURES:

- Socket Weld acc.to ASME B16.11. • Screwed ends (NPT) acc.to ASME B1.20.1. • Butt welding ends acc.to ASME B16.25. • End to End acc.to manufacturer standard. • Body-Bonnet weld acc.to ASME IX.

DESIGN TYPE E3

INTEGRAL REINFORCED EXTENDED BODY V-GROOVE SEAL WELD BODY-BONNET

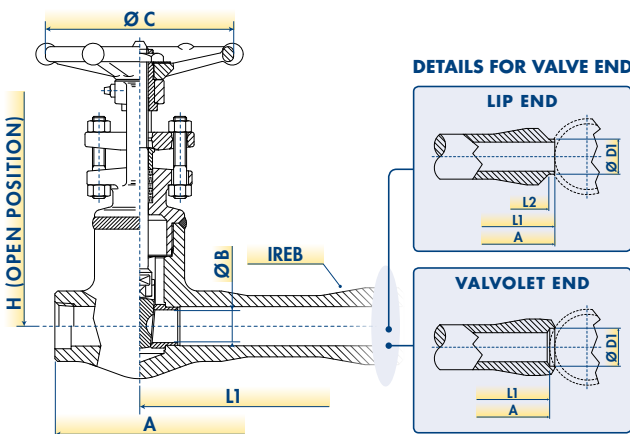

DESIGN TYPE E4

EXTENDED BODY V-GROOVE SEAL WELD BODY-BONNET CONNECTION

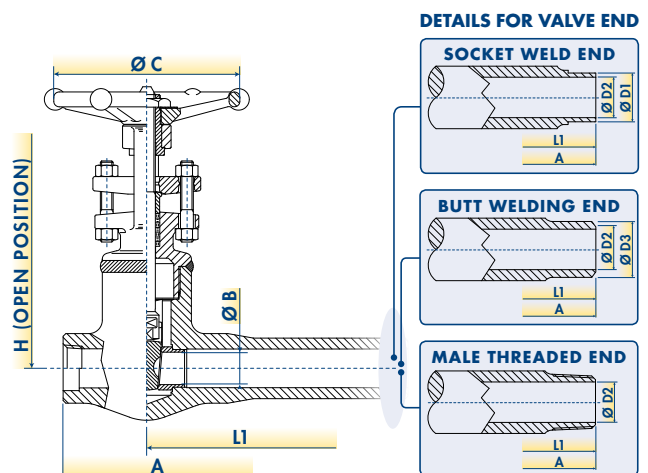

GATE VALVES

AVAILABLE OPTIONS FOR GATE VALVES

OTHER VALVE OPTIONS OR CUSTOMIZED VERSIONS ARE AVAILABLE ON REQUEST, CONTACT BFE FOR SPECIAL REQUIREMENTS.

STEM EXTENSION

Valve handle can be extended to allow for panel mount and pipe insulation.

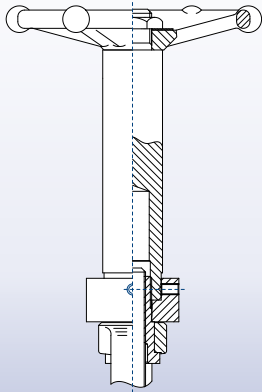

POSITION INDICATOR

Valves can be supplied with standard visual-mechanical indicating device that also acts as stem cover.

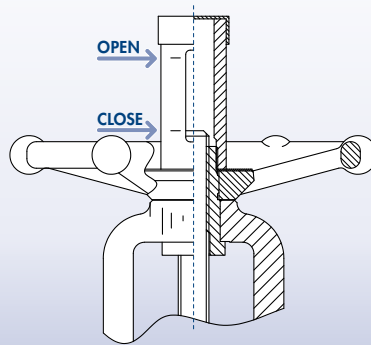

BEVEL GEAR OPERATOR

Gearing can be applied to valves instead of the standard handwheel to make operation easier.

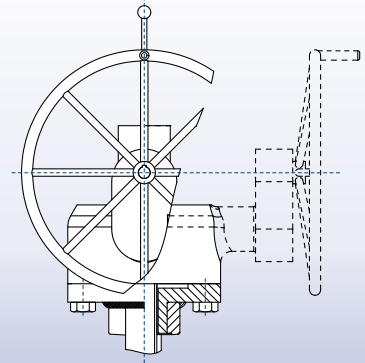

ELECTRIC, PNEUMATIC OR HYDRAULIC ACTUATORS

Motorized controls may be applied to valves of any size for operation in any position or location.

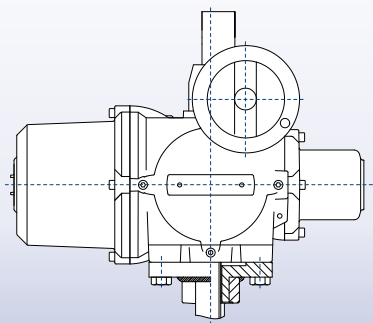

ACTUATOR-READY

Valves can be supplied ready for actuation without the handwheel or gear box. The mounting connection can be BFE Standard or can suit the choice or type of actuator.

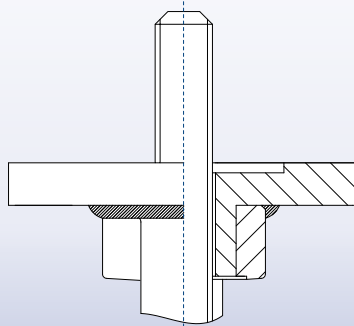

OVERPRESSURE DEVICE

Cavity over-pressurization protection can be supplied. BFE standard option is a hole performed on the seat, if required the same hole can be performed on the closure member.

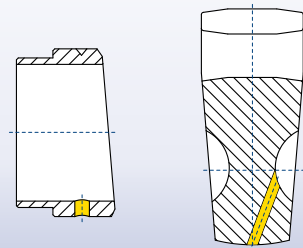

LOCKING DEVICE

Locking devices designed to help prevent accidental or unwanted operation are built to resist excessive force. All BFE locking device options are simple but secure. Chain and Padlock available on request.

LOCKING FACILITY

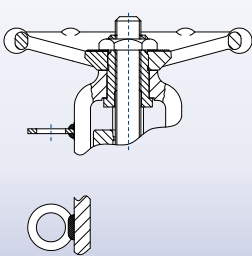

LOCKING FACILITY WITH C&P

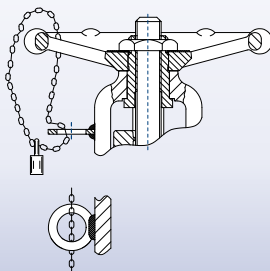

LOCKING DEVICE

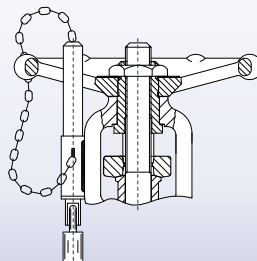

THERMAL EXPANSION STEM COMPENSATOR

Valves which endure large thermal transients have the basic problem that the valve stem and closure member will expand and contract with the danger that a closed valve could become jammed in its seat and in extreme cases this can cause the valve stem to distort. High Temperature Valve configuration is equipped with a spring loaded stem sleeve that will absorb any expansion or contraction caused by temperature fluctuations without affecting the position of the closed valve stem.

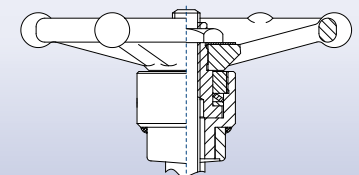

AVAILABLE OPTIONS FOR GATE VALVES

OTHER VALVE OPTIONS OR CUSTOMIZED VERSIONS ARE AVAILABLE ON REQUEST, CONTACT BFE FOR SPECIAL REQUIREMENTS.

CLOSURE MEMBER TYPE OTHER THAN SOLID WEDGE

The flex wedge

is a one piece, fully guided forged wedge with a central hub to allow the seating faces to move relative to each other thus compensating for distortion of the body seats due to thermal expansion or piping loads.

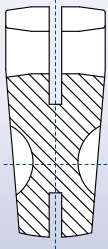

The split wedge

is self-adjusting to both seal sides and consists of two-piece construction. This type of wedge is suitable for the treatment of non-condensing gases and liquids at normal temperatures, particularly corrosive liquids.

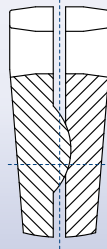

Parallel seat gate

and seat ring construction can be furnished for high differential pressure services where stem low torque is required or where high piping loads or thermal expansion may cause sticking of a wedge type gate. Spring-loaded discs are self-aligning and reduces actuator torque requirements.

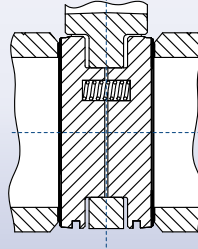

SPECIAL END FINISH

The choice of end connections for connecting a valve to its associated pipe is performed by customers. Common end finish stated in the catalogue are socket, threaded, flanged (RF or RJ) and butt-weld ends. BFE is basically able to perform any end finish as required by the customers and other end finish as follows: hub, compact flange, any ASME B16.5 end finish other than RF and RJ, etc.

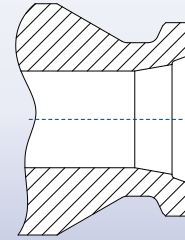

STEM DOUBLE SEAL

Stem double seals are fitted to valves when hazardous fluids are handled or when external lubrication is used. The most usual form of double seal is two sets of packing, the lantern ring can provide extra stem guidance. BFE can supply the lantern ring version with standard plug or with injector (double ball check type). Other special configurations are available on request.

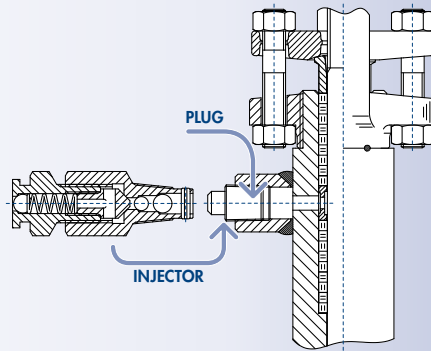

LIMIT SWITCH ASSEMBLIES

Position Limit Switch assemblies enables a remote signaling of the control system the opening of the valve. It can be equipped with one or two switches actuated by closing or opening of the valve. Limit switch can be selected by customer, bracket is designed by BFE.

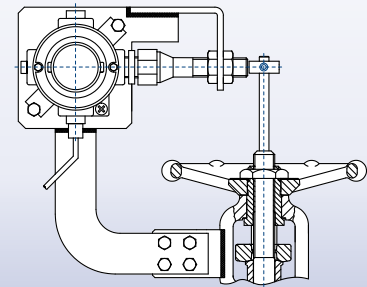

BODY-BONNET FULL PENETRATION WELD

BFE standard welded bonnet valves have as standard a seal weld on the body-bonnet connection. Seal weld is a weld that does not contribute anything to the mechanical integrity of an assembly, but is made purely to seal or prevent leakage from, for instance, a threaded joint. When High-End quality is required for body-bonnet weld joint a weld with full penetration can be performed. Full penetration weld is one in which there is a complete penetration and fusion of weld and parent metal throughout the thickness of the joint. A full penetration weld ensures a fully welded interface between the two parts and is generally the strongest joint.

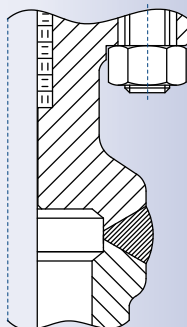

LIVE LOADING

Live Loading System consists of a spring system installed on packing stud to warrant a continuous load on valve packing. Spring are specially designed to allow appropriate load in case of packing settling by minimizing initial load and friction. Mechanical visual indicator of the spring compression is included.

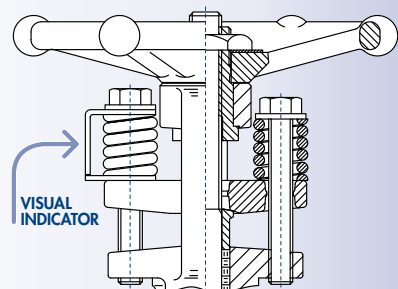

"T"-PATTERN GLOBE VALVES

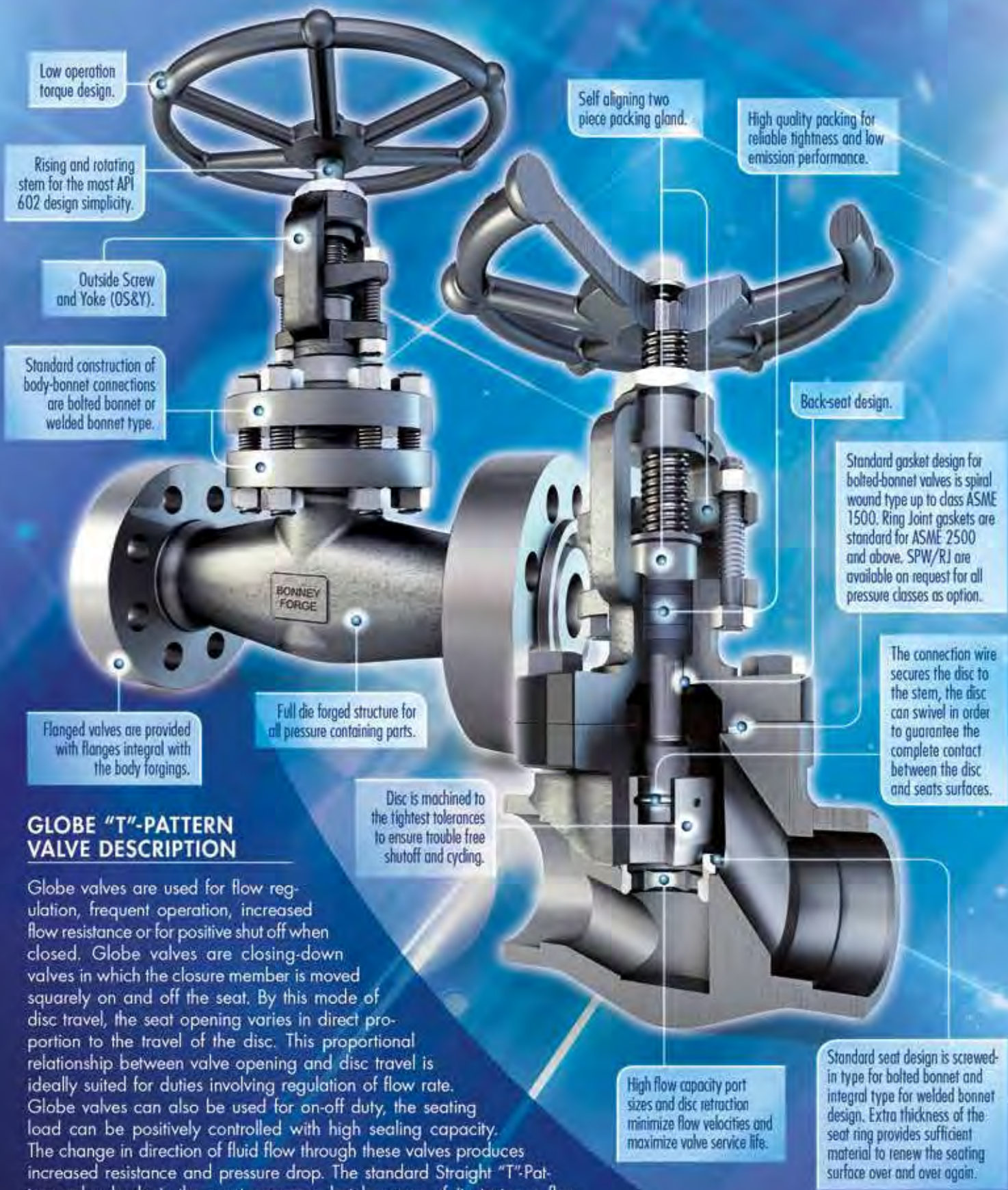

GLOBE "T"-PATTERN VALVE DESCRIPTION

Globe valves are used for flow regulation, frequent operation, increased flow resistance or for positive shut off when closed. Globe valves are closing-down valves in which the closure member is moved squarely on and off the seat. By this mode of disc travel, the seat opening varies in direct proportion to the travel of the disc. This proportional relationship between valve opening and disc travel is ideally suited for duties involving regulation of flow rate. Globe valves can also be used for on-off duty, the seating load can be positively controlled with high sealing capacity. The change in direction of fluid flow through these valves produces increased resistance and pressure drop. The standard Straight "T"-Pattern valve body is the most common, but because of its tortuous flow passage it offers the highest resistance to flow of the patterns available. Globe valves are used in many industrial applications including the oil and gas industry, pharmaceutical, manufacturing, automotive, and marine. Globe valves are also recommended for services requiring frequent operation and positive shut off.







P&ID SYMBOL









STANDARD CONFIGURATIONS



SECTION INDEX OF "T"-PATTERN GLOBE VALVES

PAGE	DESCRIPTION	SYM
C-3	BOLTED BONNET GLOBE VALVES BASIC CONFIGURATION THREADED AND SOCKET WELD ENDS	
C-4	BOLTED BONNET GLOBE VALVES BASIC CONFIGURATION ASME INTEGRAL FLANGED ENDS	
C-5	BOLTED BONNET GLOBE VALVES CRYOGENIC CONFIGURATION THREADED AND SOCKET WELD ENDS	
C-6	BOLTED BONNET GLOBE VALVES CRYOGENIC CONFIGURATION ASME INTEGRAL FLANGED ENDS	
C-7	BOLTED BONNET GLOBE VALVES BELLOW SEAL CONFIGURATION THREADED AND SOCKET WELD ENDS	
C-8	BOLTED BONNET GLOBE VALVES BELLOW SEAL CONFIGURATION ASME INTEGRAL FLANGED ENDS	

PAGE	DESCRIPTION	SYM
C-9	WELDED BONNET GLOBE VALVES BASIC CONFIGURATION THREADED AND SOCKET WELD ENDS	
C-10	WELDED BONNET GLOBE VALVES BASIC CONFIGURATION ASME INTEGRAL FLANGED ENDS	
C-11	WELDED BONNET GLOBE VALVES CRYOGENIC CONFIGURATION THREADED AND SOCKET WELD ENDS	
C-12	WELDED BONNET GLOBE VALVES CRYOGENIC CONFIGURATION ASME INTEGRAL FLANGED ENDS	
C-13	WELDED BONNET GLOBE VALVES BELLOW SEAL CONFIGURATION THREADED AND SOCKET WELD ENDS	
C-14	WELDED BONNET GLOBE VALVES BELLOW SEAL CONFIGURATION ASME INTEGRAL FLANGED ENDS	
C-15	AVAILABLE OPTIONS FOR "T" PATTERN GLOBE VALVES	

APPLICABLE STANDARDS	
DESIGN	API 602 - ISO 15761 - ASME B16.34
INSPECTION & TESTING	API 598
MARKING	MSS SP-25
RATING	ASME B16.34
FUGITIVE EMISSION	API 624 - ISO 15848

"T"-PATTERN GLOBE VALVES

BOLTED BONNET GLOBE VALVES BASIC CONFIGURATION THREADED AND SOCKET WELD ENDS



WORKING PRESSURE RATING	SIZE		STANDARD DESIGN TYPE	A		B		C		H		WEIGHT		FIGURE
	NPS	DN		mm	in	mm	in	mm	in	mm	in	kg	lb	
ASME 800	1/2"	15	S1	80	3.15	9	0.35	88	3.5	166	6.5	2.1	4.6	HL 303
	3/4"	20	S1	90	3.54	13	0.51	88	3.5	171	6.7	2.3	5.0	HL 304
	1"	25	S1	110	4.33	17	0.66	97	3.8	213	8.4	3.7	8.2	HL 305
	1-1/2"	40	S1	150	5.91	29	1.14	138	5.4	258	10.2	7.4	16.3	HL 307
	2"	50	S1	180	7.09	35	1.38	172	6.8	300	11.8	11.9	26.2	HL 308
ASME 1500	1/2"	15	S1	90	3.54	9	0.35	88	3.5	166	6.5	2.4	5.3	9HL 303
	3/4"	20	S1	110	4.33	12	0.47	97	3.8	210	8.3	4	8.8	9HL 304
	1"	25	S1	127	5.00	15	0.59	138	5.4	250	9.8	6.5	14.3	9HL 305
	1-1/2"	40	S1	180	7.09	27	1.06	172	6.8	300	11.8	13	28.7	9HL 307
	2"	50	S1	210	8.27	32	1.26	172	6.8	375	14.8	22	48.5	9HL 308
ASME 800	1/4"	6	S1	80	3.15	7	0.28	88	3.5	166	6.5	2.2	4.9	H 301
	3/8"	10	S1	80	3.15	9	0.35	88	3.5	166	6.5	2.2	4.9	H 302
	1/2"	15	S1	90	3.54	13	0.51	88	3.5	171	6.7	2.4	5.3	H 303
	3/4"	20	S1	110	4.33	17	0.66	97	3.8	213	8.4	3.8	8.4	H 304
	1"	25	S1	127	5.00	22	0.86	138	5.4	247	9.7	6.1	13.4	H 305
	1-1/4"	32	S1	150	5.91	29	1.14	138	5.4	258	10.2	7.6	16.8	H 306
	1-1/2"	40	S1	180	7.09	35	1.38	172	6.8	300	11.8	12.5	27.6	H 307
	2"	50	S1	210	8.27	45	1.77	172	6.8	375	14.8	19.6	43.2	H 308
ASME 1500	1/4"	6	S1	90	3.54	7	0.28	88	3.5	166	6.5	2.6	5.7	9H 301
	3/8"	10	S1	90	3.54	9	0.35	88	3.5	166	6.5	2.6	5.7	9H 302
	1/2"	15	S1	110	4.33	12	0.47	97	3.8	210	8.3	4.2	9.3	9H 303
	3/4"	20	S1	127	5.00	15	0.59	138	5.4	247	9.7	6.5	14.3	9H 304
	1"	25	S1	150	5.91	20	0.79	138	5.4	256	10.1	8.5	18.7	9H 305
	1-1/4"	32	S1	180	7.09	27	1.06	172	6.8	300	11.8	12.5	27.6	9H 306
	1-1/2"	40	S1	210	8.27	32	1.26	172	6.8	375	14.8	22.3	49.2	9H 307
	2"	50	S1	210	8.27	38	1.50	234	9.2	428	16.9	36	79.4	9H 308
ASME 2500	1/2"	15	S2	150	5.91	11	0.43	138	5.4	304	12.0	10	22.0	25HR 303
	3/4"	20	S2	150	5.91	14.5	0.57	138	5.4	304	12.0	10	22.0	25HR 304
	1"	25	S2	210	8.27	19	0.75	138	5.4	362	14.3	22	48.5	25HR 305
	1-1/2"	40	S2	230	9.06	28	1.10	234	9.2	436	17.2	38	83.8	25HR 307
	2"	50	S2	230	9.06	38	1.50	234	9.2	436	17.2	38	83.8	25HR 308

STANDARD BORE

FULL BORE

BFE reserves the right to change designs, dimensions or specifications without notice.

PRODUCT FEATURES:

- Socket Weld acc.to ASME B16.11. • Screwed ends (NPT) acc.to ASME B1.20.1. • Butt welding ends acc.to ASME B16.25. • End to End acc.to manufacturer standard.

DESIGN TYPE S1 SPIRAL WOUND GASKET BODY-BONNET CONNECTION

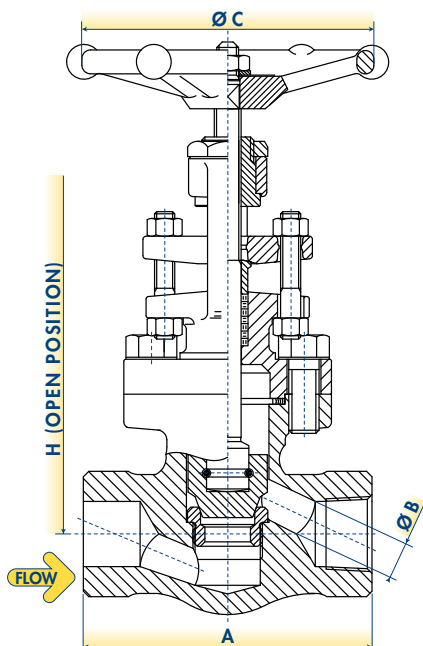

DESIGN TYPE S2 RING JOINT BODY-BONNET CONNECTION

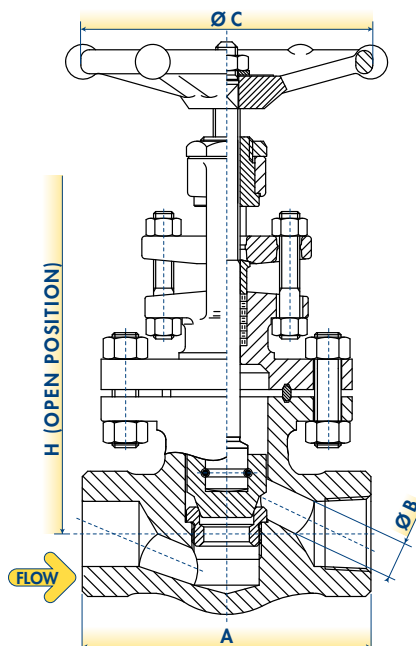

OTHER END CONNECTION TYPES AVAILABLE

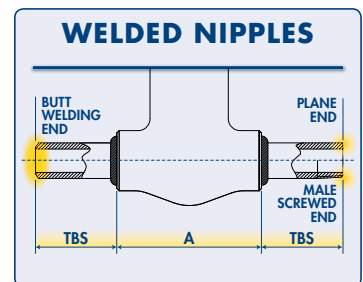
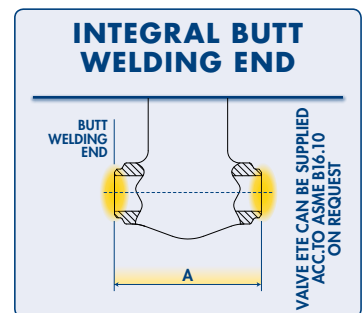

"T"-PATTERN GLOBE VALVES

BOLTED BONNET GLOBE VALVES BASIC CONFIGURATION ASME INTEGRAL FLANGED ENDS



WORKING PRESSURE RATING	SIZE		STANDARD DESIGN TYPE	A-RF		A-RJ		B		C		H		WEIGHT		FIGURE
	NPS	DN		mm	in	mm	in	mm	in	mm	in	mm	in	kg	lb	
ASME 150	1/2"	15	S1	108	4.25	N.A.	N.A.	10	0.39	88	3.5	196	7.7	3	6.6	L1-303
	3/4"	20	S1	117.5	4.63	N.A.	N.A.	14	0.55	88	3.5	196	7.7	3.8	8.4	L1-304
	1"	25	S1	127	5.00	140	5.50	17	0.66	97	3.8	226	8.9	5.5	12.1	L1-305
	1-1/2"	40	S1	165	6.50	178	7.00	29	1.14	138	5.4	273	10.7	10.3	22.7	L1-307
	2"	50	S1	203	7.99	216	8.49	35	1.38	172	6.8	300	11.8	15.8	34.8	L1-308
ASME 300	1/2"	15	S1	152.5	6.00	163.5	6.44	9	0.35	88	3.5	196	7.7	4.1	9.0	L3-303
	3/4"	20	S1	178	7.01	190.5	7.51	13	0.51	88	3.5	202	8.0	6	13.2	L3-304
	1"	25	S1	203	7.99	216	8.49	17	0.66	97	3.8	226	8.9	8.3	18.3	L3-305
	1-1/2"	40	S1	229	9.02	241	9.52	29	1.14	138	5.4	270	10.6	15.5	34.2	L3-307
	2"	50	S1	267	10.51	282.5	11.13	35	1.38	172	6.8	321	12.6	21.5	47.4	L3-308
ASME 600	1/2"	15	S1	165	6.50	163.5	6.44	9	0.35	88	3.5	177	7.0	4.4	9.7	L6-303
	3/4"	20	S1	191	7.52	190.5	7.52	13	0.51	88	3.5	202	8.0	6.2	13.7	L6-304
	1"	25	S1	216	8.50	216	8.50	17	0.66	97	3.8	234	9.2	8.7	19.2	L6-305
	1-1/2"	40	S1	241	9.49	241	9.49	29	1.14	138	5.4	270	10.6	16.5	36.4	L6-307
	2"	50	S1	292	11.50	295	11.62	35	1.38	172	6.8	321	12.6	23.6	52.0	L6-308
ASME 1500	1/2"	15	S1	216	8.50	216	8.50	9	0.35	88	3.5	190	7.5	7.6	16.8	15FL 303
	3/4"	20	S1	229	9.02	229	9.02	14	0.55	97	3.8	230	9.1	11.6	25.6	15FL 304
	1"	25	S1	254	10.00	254	10.00	14	0.55	138	5.4	270	10.6	15.3	33.7	15FL 305
	1-1/2"	40	S1	305	12.01	305	12.01	26	1.02	172	6.8	315	12.4	34.2	75.4	15FL 307
	2"	50	S1	368	14.49	371.5	14.61	34	1.34	172	6.8	355	14.0	52.2	115.1	15FL 308
ASME 150	1/2"	15	S1	108	4.25	N.A.	N.A.	13	0.51	88	3.5	196	7.7	3.8	8.4	1-303
	3/4"	20	S1	117.5	4.63	N.A.	N.A.	17.5	0.69	97	3.8	230	9.1	6.4	14.1	1-304
	1"	25	S1	127	5.00	140	5.50	22.5	0.89	138	5.4	268	10.6	8.7	19.2	1-305
	1-1/2"	40	S1	165	6.50	178	7.00	35	1.38	172	6.8	315	12.4	16.5	36.4	1-307
	2"	50	S1	203	7.99	216	8.49	45	1.77	172	6.8	335	13.2	25	55.1	1-308
ASME 300	1/2"	15	S1	152.5	6.00	163.5	6.44	13	0.51	88	3.5	196	7.7	4.1	9.0	3-303
	3/4"	20	S1	178	7.01	190.5	7.51	17.5	0.69	97	3.8	230	9.1	7	15.4	3-304
	1"	25	S1	203	7.99	216	8.49	22.5	0.89	138	5.4	268	10.6	9.7	21.4	3-305
	1-1/2"	40	S1	229	9.02	241	9.52	35	1.38	172	6.8	315	12.4	18.5	40.8	3-307
	2"	50	S1	267	10.51	282.5	11.13	45	1.77	172	6.8	335	13.2	28	61.7	3-308
ASME 600	1/2"	15	S1	165	6.50	163.5	6.44	13	0.51	88	3.5	196	7.7	5.9	13.0	6-303
	3/4"	20	S1	191	7.52	190.5	7.52	17.5	0.69	97	3.8	230	9.1	8	17.6	6-304
	1"	25	S1	216	8.50	216	8.50	22.5	0.89	138	5.4	268	10.6	10.5	23.1	6-305
	1-1/2"	40	S1	241	9.49	241	9.49	35	1.38	172	6.8	315	12.4	19.5	43.0	6-307
	2"	50	S1	292	11.50	295	11.62	45	1.77	172	6.8	370	14.6	28.5	62.8	6-308
ASME 1500	1/2"	15	S1	216	8.50	216	8.50	12	0.47	97	3.8	240	9.4	8.5	18.7	15F 303
	3/4"	20	S1	229	9.02	229	9.02	14.5	0.57	138	5.4	280	11.0	12.9	28.4	15F 304
	1"	25	S1	254	10.00	254	10.00	19	0.75	172	6.8	295	11.6	17	37.5	15F 305
	1-1/2"	40	S1	305	12.01	305	12.01	31	1.22	172	6.8	370	14.6	30	66.1	15F 307
	2"	50	S1	368	14.49	371.5	14.61	38	1.50	234	9.2	465	18.3	58	127.9	15F 308
ASME 2500	1/2"	15	S2	264	10.39	264	10.39	11	0.43	138	5.4	310	12.2	16.5	36.4	25RF 303
	3/4"	20	S2	273	10.75	273	10.75	14.5	0.57	138	5.4	315	12.4	18.5	40.8	25RF 304
	1"	25	S2	308	12.13	308	12.13	19	0.75	172	6.8	350	13.8	30	66.1	25RF 305
	1-1/2"	40	S2	384	15.12	387	15.24	28	1.10	234	9.2	450	17.7	61.5	135.6	25RF 307
	2"	50	S2	451	17.76	454	17.88	38	1.50	320	12.6	460	18.1	67	147.7	25RF 308

STANDARD BORE

FULL BORE

BFE reserves the right to change designs, dimensions or specifications without notice.

PRODUCT FEATURES:

- Flanged ends acc.to ASME B16.5.
- Face to Face acc.to ASME B16.10.

DESIGN TYPE S1

SPIRAL WOUND GASKET BODY-BONNET CONNECTION

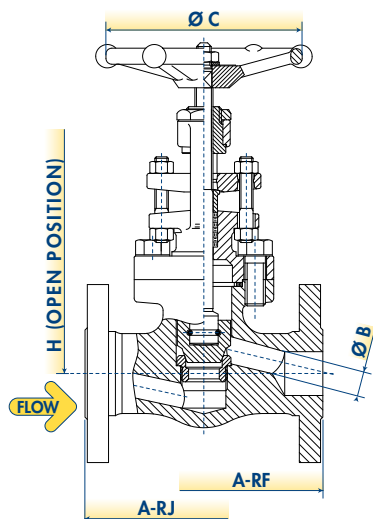

DESIGN TYPE S2

RING JOINT BODY-BONNET CONNECTION

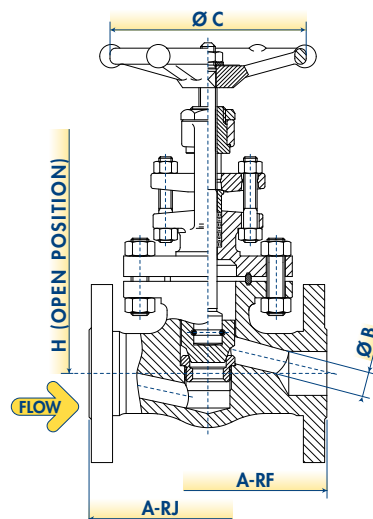

"T"-PATTERN GLOBE VALVES

BOLTED BONNET GLOBE VALVES CRYOGENIC CONFIGURATION THREADED AND SOCKET WELD ENDS



WORKING PRESSURE RATING	SIZE		STANDARD DESIGN TYPE	A		B		C		H		WEIGHT		FIGURE
	NPS	DN		mm	in	mm	in	mm	in	mm	in	kg	lb	
ASME 800	1/2"	15	S1	80	3.15	9	0.35	88	3.5	420	16.5	3.3	7.3	CL 303
	3/4"	20	S1	90	3.54	13	0.51	88	3.5	425	16.7	3.8	8.4	CL 304
	1"	25	S1	110	4.33	17	0.66	97	3.8	467	18.4	5.2	11.5	CL 305
	1-1/2"	40	S1	150	5.91	29	1.14	138	5.4	512	20.2	9.8	21.6	CL 307
	2"	50	S1	180	7.09	35	1.38	172	6.8	554	21.8	14.8	32.6	CL 308
ASME 1500	1/2"	15	S1	90	3.54	9	0.35	88	3.5	420	16.5	3.7	8.2	9CL 303
	3/4"	20	S1	110	4.33	12	0.47	97	3.8	464	18.3	5.4	11.9	9CL 304
	1"	25	S1	127	5.00	15	0.59	138	5.4	504	19.8	8.9	19.6	9CL 305
	1-1/2"	40	S1	180	7.09	27	1.06	172	6.8	554	21.8	15.8	34.8	9CL 307
	2"	50	S1	210	8.27	32	1.26	172	6.8	629	24.8	27.5	60.6	9CL 308
ASME 800	1/4"	6	S1	80	3.15	7	0.28	88	3.5	420	16.5	3.5	7.7	C 301
	3/8"	10	S1	80	3.15	9	0.35	88	3.5	420	16.5	3.5	7.7	C 302
	1/2"	15	S1	90	3.54	13	0.51	88	3.5	425	16.7	3.6	7.9	C 303
	3/4"	20	S1	110	4.33	17	0.66	97	3.8	467	18.4	5.1	11.2	C 304
	1"	25	S1	127	5.00	22	0.86	138	5.4	501	19.7	8.4	18.5	C 305
	1-1/4"	32	S1	150	5.91	29	1.14	138	5.4	512	20.2	12.6	27.8	C 306
	1-1/2"	40	S1	180	7.09	35	1.38	172	6.8	554	21.8	16.5	36.4	C 307
2"	50	S1	210	8.27	45	1.77	172	6.8	629	24.8	24	52.9	C 308	
ASME 1500	1/4"	6	S1	90	3.54	7	0.28	88	3.5	420	16.5	4	8.8	9C 301
	3/8"	10	S1	90	3.54	9	0.35	88	3.5	420	16.5	4	8.8	9C 302
	1/2"	15	S1	110	4.33	12	0.47	97	3.8	464	18.3	5.5	12.1	9C 303
	3/4"	20	S1	127	5.00	15	0.59	138	5.4	501	19.7	8	17.6	9C 304
	1"	25	S1	150	5.91	20	0.79	138	5.4	510	20.1	11	24.3	9C 305
	1-1/4"	32	S1	180	7.09	27	1.06	172	6.8	554	21.8	15.5	34.2	9C 306
	1-1/2"	40	S1	210	8.27	32	1.26	172	6.8	629	24.8	25	55.1	9C 307
2"	50	S1	210	8.27	38	1.50	234	9.2	682	26.9	41	90.4	9C 308	
ASME 2500	1/2"	15	S2	150	5.91	11	0.43	138	5.4	558	22.0	12.5	27.6	25CHR 303
	3/4"	20	S2	150	5.91	14.5	0.57	138	5.4	558	22.0	12.5	27.6	25CHR 304
	1"	25	S2	210	8.27	19	0.75	138	5.4	616	24.3	26	57.3	25CHR 305
	1-1/2"	40	S2	230	9.06	28	1.10	234	9.2	690	27.2	44	97.0	25CHR 307
	2"	50	S2	230	9.06	38	1.50	234	9.2	690	27.2	44	97.0	25CHR 308

STANDARD BORE

FULL BORE

BFE reserves the right to change designs, dimensions or specifications without notice.

PRODUCT FEATURES:

- Socket Weld acc.to ASME B16.11. • Screwed ends (NPT) acc.to ASME B1.20.1. • Butt welding ends acc.to ASME B16.25. • End to End acc.to manufacturer standard. • Cryogenic design acc.to BS 6364.

DESIGN TYPE S1 SPIRAL WOUND GASKET BODY-BONNET CONNECTION

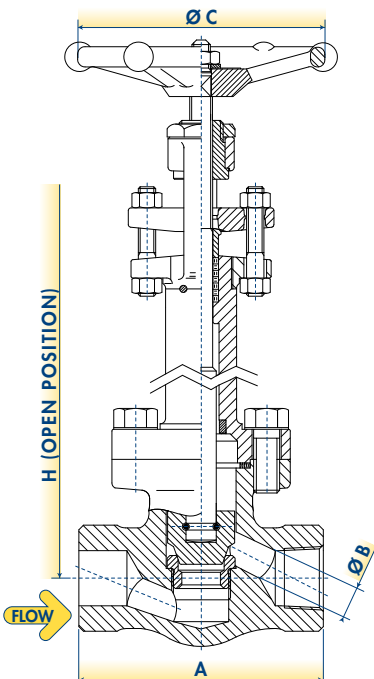

DESIGN TYPE S2 RING JOINT BODY-BONNET CONNECTION

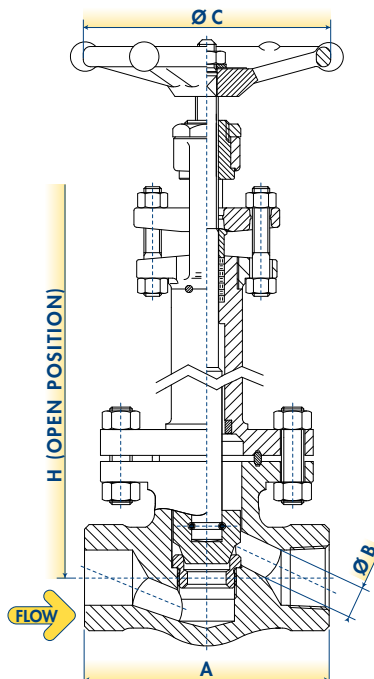

OTHER END CONNECTION TYPES AVAILABLE

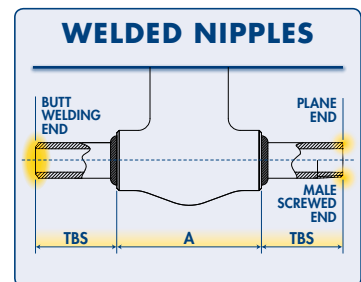
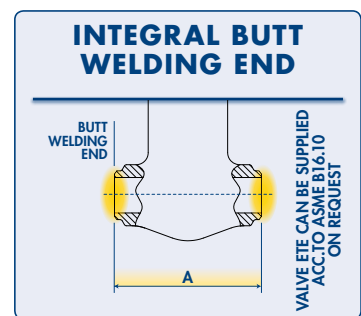

"T"-PATTERN GLOBE VALVES

BOLTED BONNET GLOBE VALVES CRYOGENIC CONFIGURATION ASME INTEGRAL FLANGED ENDS



WORKING PRESSURE RATING	SIZE		STANDARD DESIGN TYPE	A-RF		A-RJ		B		C		H		WEIGHT		FIGURE
	NPS	DN		mm	in	mm	in	mm	in	mm	in	mm	in	kg	lb	
ASME 150	1/2"	15	S1	108	4.25	N.A.	N.A.	10	0.39	88	3.5	450	17.7	4.6	10.1	1CL-303
	3/4"	20	S1	117.5	4.63	N.A.	N.A.	14	0.55	88	3.5	450	17.7	5.2	11.5	1CL-304
	1"	25	S1	127	5.00	140	5.50	17	0.66	97	3.8	480	18.9	6.7	14.8	1CL-305
	1-1/2"	40	S1	165	6.50	178	7.00	29	1.14	138	5.4	527	20.7	12.5	27.6	1CL-307
	2"	50	S1	203	7.99	216	8.49	35	1.38	172	6.8	554	21.8	19	41.9	1CL-308
ASME 300	1/2"	15	S1	152.5	6.00	163.5	6.44	9	0.35	88	3.5	450	17.7	5.6	12.3	3CL-303
	3/4"	20	S1	178	7.01	190.5	7.51	13	0.51	88	3.5	456	18.0	6.7	14.8	3CL-304
	1"	25	S1	203	7.99	216	8.49	17	0.66	97	3.8	480	18.9	9.8	21.6	3CL-305
	1-1/2"	40	S1	229	9.02	241	9.52	29	1.14	138	5.4	524	20.6	17.5	38.6	3CL-307
	2"	50	S1	267	10.51	282.5	11.13	35	1.38	172	6.8	575	22.6	24.5	54.0	3CL-308
ASME 600	1/2"	15	S1	165	6.50	163.5	6.44	9	0.35	88	3.5	431	17.0	5.9	13.0	6CL-303
	3/4"	20	S1	191	7.52	190.5	7.52	13	0.51	88	3.5	456	18.0	7.6	16.8	6CL-304
	1"	25	S1	216	8.50	216	8.50	17	0.66	97	3.8	488	19.2	10.2	22.5	6CL-305
	1-1/2"	40	S1	241	9.49	241	9.49	29	1.14	138	5.4	524	20.6	19	41.9	6CL-307
	2"	50	S1	292	11.50	295	11.62	35	1.38	172	6.8	575	22.6	26	57.3	6CL-308
ASME 1500	1/2"	15	S1	216	8.50	216	8.50	9	0.35	88	3.5	444	17.5	8.3	18.3	15CFL-303
	3/4"	20	S1	229	9.02	229	9.02	14	0.55	97	3.8	484	19.1	12.5	27.6	15CFL-304
	1"	25	S1	254	10.00	254	10.00	14	0.55	138	5.4	524	20.6	17	37.5	15CFL-305
	1-1/2"	40	S1	305	12.01	305	12.01	26	1.02	172	6.8	569	22.4	36.2	79.8	15CFL-307
	2"	50	S1	368	14.49	371.5	14.61	34	1.34	172	6.8	609	24.0	56	123.5	15CFL-308
ASME 150	1/2"	15	S1	108	4.25	N.A.	N.A.	13	0.51	88	3.5	450	17.7	4.8	10.6	1C-303
	3/4"	20	S1	117.5	4.63	N.A.	N.A.	17.5	0.69	97	3.8	484	19.1	7	15.4	1C-304
	1"	25	S1	127	5.00	140	5.50	22.5	0.89	138	5.4	522	20.6	9.5	20.9	1C-305
	1-1/2"	40	S1	165	6.50	178	7.00	35	1.38	172	6.8	569	22.4	18	39.7	1C-307
	2"	50	S1	203	7.99	216	8.49	45	1.77	172	6.8	589	23.2	27	59.5	1C-308
ASME 300	1/2"	15	S1	152.5	6.00	163.5	6.44	13	0.51	88	3.5	450	17.7	6.2	13.7	3C-303
	3/4"	20	S1	178	7.01	190.5	7.51	17.5	0.69	97	3.8	484	19.1	7.9	17.4	3C-304
	1"	25	S1	203	7.99	216	8.49	22.5	0.89	138	5.4	522	20.6	12	26.5	3C-305
	1-1/2"	40	S1	229	9.02	241	9.52	35	1.38	172	6.8	569	22.4	21	46.3	3C-307
	2"	50	S1	267	10.51	282.5	11.13	45	1.77	172	6.8	589	23.2	31	68.3	3C-308
ASME 600	1/2"	15	S1	165	6.50	163.5	6.44	13	0.51	88	3.5	450	17.7	6.5	14.3	6C-303
	3/4"	20	S1	191	7.52	190.5	7.52	17.5	0.69	97	3.8	484	19.1	8.7	19.2	6C-304
	1"	25	S1	216	8.50	216	8.50	22.5	0.89	138	5.4	522	20.6	12.6	27.8	6C-305
	1-1/2"	40	S1	241	9.49	241	9.49	35	1.38	172	6.8	569	22.4	22	48.5	6C-307
	2"	50	S1	292	11.50	295	11.62	45	1.77	172	6.8	624	24.6	34	75.0	6C-308
ASME 1500	1/2"	15	S1	216	8.50	216	8.50	12	0.47	97	3.8	494	19.4	12	26.5	15CF-303
	3/4"	20	S1	229	9.02	229	9.02	14.5	0.57	138	5.4	534	21.0	14.5	32.0	15CF-304
	1"	25	S1	254	10.00	254	10.00	19	0.75	172	6.8	549	21.6	19	41.9	15CF-305
	1-1/2"	40	S1	305	12.01	305	12.01	31	1.22	172	6.8	624	24.6	31	68.3	15CF-307
	2"	50	S1	368	14.49	371.5	14.61	38	1.50	234	9.2	719	28.3	60	132.3	15CF-308
ASME 2500	1/2"	15	S2	264	10.39	264	10.39	11	0.43	138	5.4	564	22.2	18	39.7	25CRF-303
	3/4"	20	S2	273	10.75	273	10.75	14.5	0.57	138	5.4	569	22.4	21.3	47.0	25CRF-304
	1"	25	S2	308	12.13	308	12.13	19	0.75	172	6.8	604	23.8	33	72.8	25CRF-305
	1-1/2"	40	S2	384	15.12	387	15.24	28	1.10	234	9.2	704	27.7	64.5	142.2	25CRF-307
	2"	50	S2	451	17.76	454	17.88	38	1.50	320	12.6	714	28.1	71	156.5	25CRF-308

STANDARD BORE

FULL BORE

BFE reserves the right to change designs, dimensions or specifications without notice.

PRODUCT FEATURES:

- Flanged ends acc. to ASME B16.5.
- Face to Face acc. to ASME B16.10.
- Cryogenic design acc. to BS 6364.

DESIGN TYPE S1

SPIRAL WOUND GASKET BODY-BONNET CONNECTION

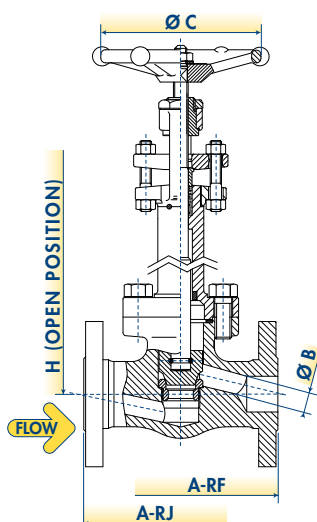

DESIGN TYPE S2

RING JOINT BODY-BONNET CONNECTION

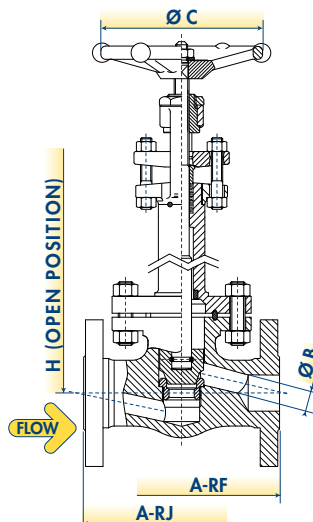

"T"-PATTERN GLOBE VALVES

BOLTED BONNET GLOBE VALVES BELLOW SEAL CONFIGURATION THREADED AND SOCKET WELD ENDS



WORKING PRESSURE RATING	SIZE		STANDARD DESIGN TYPE	A		B		C		H		WEIGHT		FIGURE
	NPS	DN		mm	in	mm	in	mm	in	mm	in	kg	lb	
ASME 800	1/2"	15	P4	80	3.15	9	0.35	88	3.5	190	7.5	2.5	5.5	SL 303
	3/4"	20	P4	90	3.54	13	0.51	88	3.5	195	7.7	2.7	6.0	SL 304
	1"	25	P4	110	4.33	17	0.66	97	3.8	225	8.9	4.3	9.5	SL 305
	1-1/2"	40	P4	150	5.91	29	1.14	138	5.4	315	12.4	8.8	19.4	SL 307
	2"	50	P4	180	7.09	35	1.38	172	6.8	356	14.0	13.5	29.8	SL 308
ASME 1500	1/2"	15	P4	90	3.54	9	0.35	138	5.4	229	9.0	3.5	7.7	9SL 303
	3/4"	20	P4	110	4.33	12	0.47	138	5.4	243	9.6	4.5	9.9	9SL 304
	1"	25	P4	127	5.00	15	0.59	172	6.8	286	11.3	7	15.4	9SL 305
	1-1/2"	40	P4	180	7.09	27	1.06	234	9.2	360	14.2	9	19.8	9SL 307
ASME 800	1/4"	6	P4	80	3.15	7	0.28	88	3.5	190	7.5	2.5	5.5	S 301
	3/8"	10	P4	80	3.15	9	0.35	88	3.5	190	7.5	2.5	5.5	S 302
	1/2"	15	P4	90	3.54	13	0.51	88	3.5	195	7.7	3.5	7.7	S 303
	3/4"	20	P4	110	4.33	17	0.66	97	3.8	225	8.9	5.2	11.5	S 304
	1"	25	P4	127	5.00	22	0.86	138	5.4	271	10.7	8.7	19.2	S 305
	1-1/4"	32	P4	150	5.91	29	1.14	138	5.4	315	12.4	10	22.0	S 306
	1-1/2"	40	P4	180	7.09	35	1.38	172	6.8	356	14.0	18.5	40.8	S 307
2"	50	P4	210	8.27	45	1.77	172	6.8	429	16.9	30.5	67.2	S 308	
ASME 1500	1/4"	6	P4	90	3.54	7	0.28	88	3.5	230	9.1	3.5	5.7	9S 301
	3/8"	10	P4	90	3.54	9	0.35	88	3.5	230	9.1	3.5	5.7	9S 302
	1/2"	15	P4	110	4.33	12	0.47	138	5.4	243	9.6	4.5	9.9	9S 303
	3/4"	20	P4	127	5.00	15	0.59	172	6.8	286	11.3	7	15.4	9S 304
	1"	25	P4	150	5.91	20	0.79	234	9.2	311	12.2	9	19.8	9S 305
	1-1/4"	32	P4	180	7.09	27	1.06	234	6.8	400	15.7	13.5	27.6	9S 306
	1-1/2"	40	P4	210	8.27	32	1.26	320	12.6	445	17.5	23	50.7	9S 307
2"	50	P4	230	8.27	38	1.50	320	12.6	510	20.1	38	83.8	9S 308	
ASME 2500	1/2"	15	P5	150	5.91	11	0.43	172	6.8	370	14.6	12	26.5	25SR 303
	3/4"	20	P5	150	5.91	14.5	0.57	234	9.2	400	15.7	12	26.5	25SR 304
	1"	25	P5	210	8.27	19	0.75	320	12.6	440	17.3	27	59.5	25SR 305
	1-1/2"	40	P5	230	9.06	28	1.10	320	12.6	490	19.3	42	92.6	25SR 307
	2"	50	P6	230	9.06	38	1.50	400	15.7	560	22.0	44	97.0	25SR 308

STANDARD BORE

FULL BORE

BFE reserves the right to change designs, dimensions or specifications without notice.

PRODUCT FEATURES:

- Socket Weld acc. to ASME B16.11. • Screwed ends (NPT) acc. to ASME B1.20.1. • Butt welding ends acc. to ASME B16.25. • End to End acc. to manufacturer standard. • Zero emission. • Hydroformed Bellows
- Extension-Bonnet weld acc. to ASME IX. • Grease nipple for yoke sleeve. • Emergency stuffing box as back sealing.

DESIGN TYPE P4

HANDWHEEL OPERATED
& SPIRAL WOUND
GASKET BODY-BONNET
CONNECTION

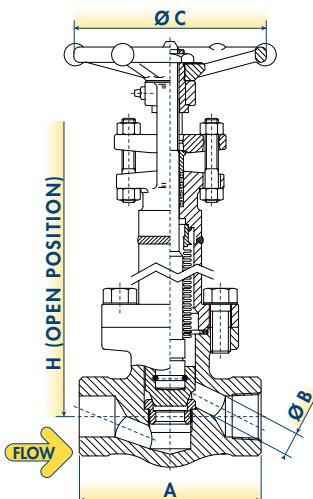

DESIGN TYPE P5

HANDWHEEL OPERATED
WITH THRUST BEARINGS
& RING JOINT GASKET
BODY-BONNET CONNECTION

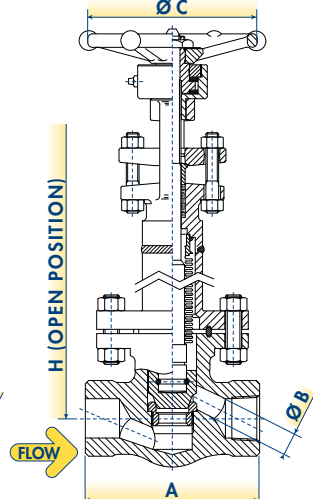

DESIGN TYPE P6

GEAR OPERATED
& RING JOINT GASKET
BODY-BONNET
CONNECTION

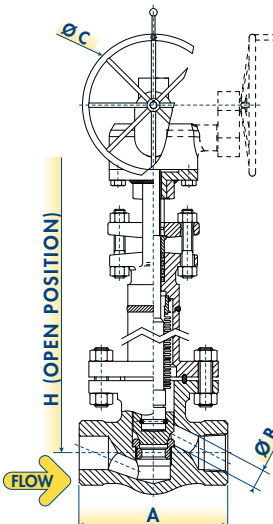

OTHER END CONNECTION TYPES AVAILABLE

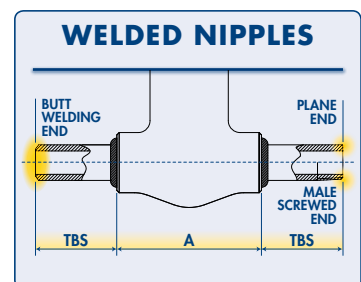
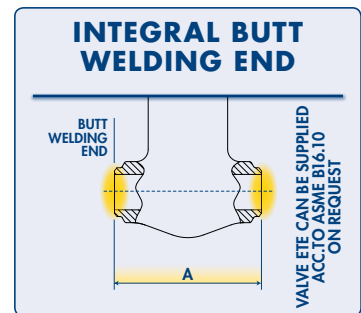

"T"-PATTERN GLOBE VALVES

BOLTED BONNET GLOBE VALVES BELLOW SEAL CONFIGURATION ASME INTEGRAL FLANGED ENDS



WORKING PRESSURE RATING	SIZE		STANDARD DESIGN TYPE	A-RF		A-RJ		B		C		H		WEIGHT		FIGURE
	NPS	DN		mm	in	mm	in	mm	in	mm	in	mm	in	kg	lb	
ASME 150	1/2"	15	P4	108	4.25	N.A.	N.A.	10	0.39	88	3.5	235	9.3	3.8	8.3	1SL 303
	3/4"	20	P4	117.5	4.63	N.A.	N.A.	14	0.55	88	3.5	235	9.3	4.8	10.5	1SL 304
	1"	25	P4	127	5.00	140	5.50	17	0.66	97	3.8	271	10.7	6.9	15.2	1SL 305
	1-1/2"	40	P4	165	6.50	178	7.00	29	1.14	138	5.4	327	12.9	12.9	28.4	1SL 307
	2"	50	P4	203	7.99	216	8.49	35	1.38	138	5.4	360	14.2	19.8	43.5	1SL 308
ASME 300	1/2"	15	P4	152.5	6.00	163.5	6.44	9	0.35	88	3.5	235	9.3	5.1	11.3	3SL 303
	3/4"	20	P4	178	7.01	190.5	7.51	13	0.51	88	3.5	242	9.5	7.5	16.5	3SL 304
	1"	25	P4	203	7.99	216	8.49	17	0.66	97	3.8	271	10.7	10.4	22.9	3SL 305
	1-1/2"	40	P4	229	9.02	241	9.52	29	1.14	138	5.4	324	12.8	19.4	42.7	3SL 307
	2"	50	P4	267	10.51	282.5	11.13	35	1.38	138	5.4	385	15.2	26.9	59.2	3SL 308
ASME 600	1/2"	15	P4	165	6.50	163.5	6.44	9	0.35	88	3.5	212	8.4	5.9	12.1	6SL 303
	3/4"	20	P4	191	7.52	190.5	7.52	13	0.51	88	3.5	242	9.5	7.8	17.1	6SL 304
	1"	25	P4	216	8.50	216	8.50	17	0.66	97	3.8	280	11.1	10.9	24.0	6SL 305
	1-1/2"	40	P4	241	9.49	241	9.49	29	1.14	138	5.4	324	12.8	20.6	45.5	6SL 307
	2"	50	P4	292	11.50	295	11.62	35	1.38	138	5.4	385	15.2	29.5	65.0	6SL 308
ASME 1500	1/2"	15	P4	216	8.50	216	8.50	9	0.35	88	3.5	228	9.0	9.5	20.9	15SFL 303
	3/4"	20	P4	229	9.02	229	9.02	14	0.55	97	3.8	276	10.9	14.5	32.0	15SFL 304
	1"	25	P4	254	10.00	254	10.00	14	0.55	172	6.8	324	12.8	19.1	42.2	15SFL 305
	1-1/2"	40	P4	305	12.01	305	12.01	26	1.02	234	9.2	378	14.9	42.8	94.2	15SFL 307
	2"	50	P4	368	14.49	371.5	14.61	34	1.34	234	9.2	426	16.8	65.3	143.9	15SFL 308
ASME 150	1/2"	15	P4	108	4.25	N.A.	N.A.	13	0.51	88	3.5	235	9.3	4.8	10.5	1S 303
	3/4"	20	P4	117.5	4.63	N.A.	N.A.	17.5	0.69	97	3.8	276	10.9	8.0	17.6	1S 304
	1"	25	P4	127	5.00	140	5.50	22.5	0.89	138	5.4	321	12.7	10.9	24.0	1S 305
	1-1/2"	40	P4	165	6.50	178	7.00	35	1.38	138	5.4	378	14.9	20.6	45.5	1S 307
	2"	50	P4	203	7.99	216	8.49	45	1.77	172	6.8	402	15.8	31.3	68.9	1S 308
ASME 300	1/2"	15	P4	152.5	6.00	163.5	6.44	13	0.51	88	3.5	235	9.3	5.1	11.3	3S 303
	3/4"	20	P4	178	7.01	190.5	7.51	17.5	0.69	97	3.8	276	10.9	8.8	19.3	3S 304
	1"	25	P4	203	7.99	216	8.49	22.5	0.89	138	5.4	321	12.7	12.1	26.7	3S 305
	1-1/2"	40	P4	229	9.02	241	9.52	35	1.38	138	5.4	378	14.9	23.1	51.0	3S 307
	2"	50	P4	267	10.51	282.5	11.13	45	1.77	172	6.8	402	15.8	35.0	77.2	3S 308
ASME 600	1/2"	15	P4	165	6.50	163.5	6.44	13	0.51	88	3.5	235	9.3	7.4	16.3	6S 303
	3/4"	20	P4	191	7.52	190.5	7.52	17.5	0.69	97	3.8	276	10.9	10.0	22.0	6S 304
	1"	25	P4	216	8.50	216	8.50	22.5	0.89	138	5.4	321	12.7	13.1	28.9	6S 305
	1-1/2"	40	P4	241	9.49	241	9.49	35	1.38	138	5.4	378	14.9	24.4	53.7	6S 307
	2"	50	P4	292	11.50	295	11.62	45	1.77	172	6.8	444	17.5	35.6	78.5	6S 308
ASME 1500	1/2"	15	P4	216	8.50	216	8.50	12	0.47	138	5.4	288	11.3	10.6	23.4	15SF 303
	3/4"	20	P4	229	9.02	229	9.02	14.5	0.57	138	5.4	336	13.2	16.1	35.5	15SF 304
	1"	25	P4	254	10.00	254	10.00	19	0.75	138	5.4	354	13.9	21.3	46.8	15SF 305
	1-1/2"	40	P4	305	12.01	305	12.01	31	1.22	172	6.8	444	17.5	37.5	82.7	15SF 307
	2"	50	P4	368	14.49	371.5	14.61	38	1.50	234	9.2	558	22.0	72.5	159.8	15SF 308
ASME 2500	1/2"	15	P5	264	10.39	264	10.39	11	0.43	138	5.4	372	14.6	20.6	45.5	25SRF 303
	3/4"	20	P5	273	10.75	273	10.75	14.5	0.57	138	5.4	378	14.9	23.1	51.0	25SRF 304
	1"	25	P5	308	12.13	308	12.13	19	0.75	172	6.8	420	16.5	37.5	82.7	25SRF 305
	1-1/2"	40	P5	384	15.12	387	15.24	28	1.10	234	9.2	540	21.3	76.9	169.5	25SRF 307
	2"	50	P6	451	17.76	454	17.88	38	1.50	400	15.7	552	21.7	83.8	184.6	25SRF 308

STANDARD BORE

FULL BORE

BFE reserves the right to change designs, dimensions or specifications without notice.

PRODUCT FEATURES:

- Flanged ends acc.to ASME B16.5. • Face to Face acc.to ASME B16.10. • Zero emission. • Hydroformed Bellows • Extension-Bonnet weld acc.to ASME IX. • Grease nipple for yoke sleeve. • Emergency stuffing box as back sealing.

DESIGN TYPE P4

**HANDWHEEL OPERATED
& SPIRAL WOUND
GASKET BODY-BONNET
CONNECTION**

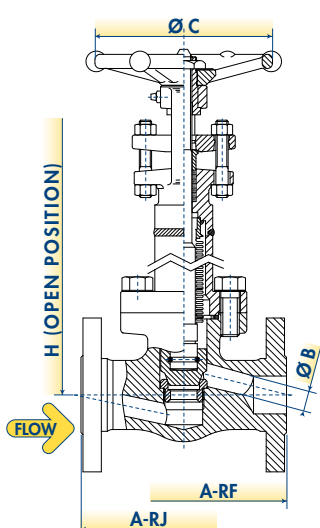

DESIGN TYPE P5

**HANDWHEEL OPERATED
WITH THRUST BEARINGS &
RING JOINT GASKET
BODY-BONNET CONNECTION**

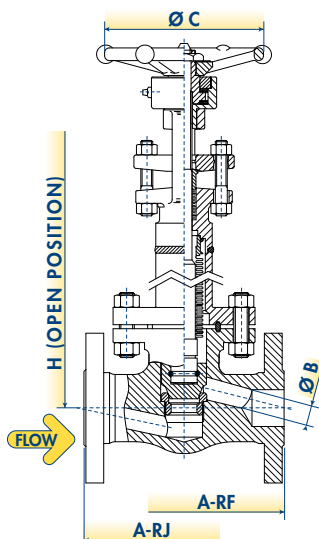

DESIGN TYPE P6

**GEAR OPERATED & RING
JOINT GASKET
BODY-BONNET
CONNECTION**

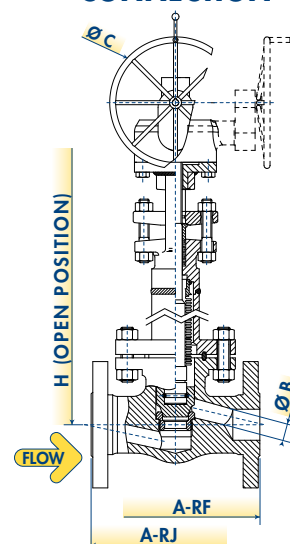

"T"-PATTERN GLOBE VALVES

WELDED BONNET GLOBE VALVES BASIC CONFIGURATION THREADED AND SOCKET WELD ENDS



WORKING PRESSURE RATING	SIZE		STANDARD DESIGN TYPE	A		B		C		H		WEIGHT		FIGURE
	NPS	DN		mm	in	mm	in	mm	in	mm	in	kg	lb	
ASME 800	1/2"	15	W1	80	3.15	9	0.35	88	3.5	166	6.5	1.7	3.7	WL 303
	3/4"	20	W1	90	3.54	13	0.51	88	3.5	171	6.7	2	4.4	WL 304
	1"	25	W1	110	4.33	17	0.66	97	3.8	213	8.4	3	6.6	WL 305
	1-1/2"	40	W1	150	5.91	29	1.14	138	5.4	258	10.2	6.6	14.6	WL 307
	2"	50	W1	180	7.09	35	1.38	172	6.8	300	11.8	10.4	22.9	WL 308
ASME 1500	1/2"	15	W1	90	3.54	9	0.35	88	3.5	166	6.5	2	4.4	9WL 303
	3/4"	20	W1	110	4.33	12	0.47	97	3.8	210	8.3	3.5	7.7	9WL 304
	1"	25	W1	127	5.00	15	0.59	138	5.4	247	9.7	5.5	12.1	9WL 305
	1-1/2"	40	W1	180	7.09	27	1.06	172	6.8	300	11.8	12	26.5	9WL 307
	2"	50	W1	210	8.27	32	1.26	172	6.8	375	14.8	19	41.9	9WL 308
ASME 800	1/4"	6	W1	80	3.15	7	0.28	88	3.5	166	6.5	1.7	3.7	W 301
	3/8"	10	W1	80	3.15	9	0.35	88	3.5	166	6.5	1.8	4.0	W 302
	1/2"	15	W1	90	3.54	13	0.51	88	3.5	171	6.7	2	4.4	W 303
	3/4"	20	W1	110	4.33	17	0.66	97	3.8	213	8.4	3	6.6	W 304
	1"	25	W1	127	5.00	22	0.86	138	5.4	247	9.7	5	11.0	W 305
	1-1/4"	32	W1	150	5.91	29	1.14	138	5.4	258	10.2	6.8	15.0	W 306
	1-1/2"	40	W1	180	7.09	35	1.38	172	6.8	300	11.8	11	24.3	W 307
	2"	50	W1	210	8.27	45	1.77	172	6.8	375	14.8	16.5	36.4	W 308
ASME 1500	1/4"	6	W1	90	3.54	7	0.28	88	3.5	166	6.5	2.2	4.9	9W 301
	3/8"	10	W1	90	3.54	9	0.35	88	3.5	166	6.5	2.2	4.9	9W 302
	1/2"	15	W1	110	4.33	12	0.47	97	3.8	210	8.3	3.5	7.7	9W 303
	3/4"	20	W1	127	5.00	15	0.59	138	5.4	247	9.7	5.5	12.1	9W 304
	1"	25	W1	150	5.91	20	0.79	138	5.4	256	10.1	7.6	16.8	9W 305
	1-1/4"	32	W1	180	7.09	27	1.06	172	6.8	300	11.8	10	22.0	9W 306
	1-1/2"	40	W1	210	8.27	32	1.26	172	6.8	375	14.8	20	44.1	9W 307
	2"	50	W1	210	8.27	43	1.69	234	9.2	428	16.9	30	66.1	9W 308
ASME 2500	1/4"	6	W2	90	3.54	7	0.28	88	3.5	190	7.5	4.5	9.9	25W 301
	3/8"	10	W2	90	3.54	9	0.35	88	3.5	190	7.5	4.7	10.4	25W 302
	1/2"	15	W2	110	4.33	11	0.43	138	5.4	226	8.9	5.5	12.1	25W 303
	3/4"	20	W2	127	5.00	14.5	0.57	138	5.4	247	9.7	8	17.6	25W 304
	1"	25	W2	180	7.09	19	0.75	138	5.4	288	11.3	13	28.7	25W 305
	1-1/4"	32	W2	180	7.09	26	1.02	138	5.4	288	11.3	13	28.7	25W 306
	1-1/2"	40	W2	210	8.27	29	1.14	172	6.8	360	14.2	19.8	43.7	25W 307
	2"	50	W2	230	9.06	38	1.50	234	9.2	420	16.5	30	66.1	25W 308
ASME 4500	1/4"	6	W2	127	5.00	7	0.28	138	5.4	230	9.1	6.5	14.3	45W 301
	3/8"	10	W2	127	5.00	7	0.28	138	5.4	230	9.1	6.5	14.3	45W 302
	1/2"	15	W2	127	5.00	8	0.31	138	5.4	235	9.3	6.5	14.3	45W 303
	3/4"	20	W2	180	7.09	11	0.43	172	6.8	300	11.8	15	33.1	45W 304
	1"	25	W2	180	7.09	14	0.55	172	6.8	300	11.8	15	33.1	45W 305
	1-1/2"	40	W2	230	9.06	25	0.98	234	9.2	370	14.6	25	55.1	45W 307
	2"	50	W4	230	9.06	32	1.26	400	15.7	400	15.7	30	66.1	45W 308

STANDARD BORE

FULL BORE

BP reserves the right to change designs, dimensions or specifications without notice.

PRODUCT FEATURES:

- Socket Weld acc. to ASME B16.11. • Screwed ends (NPT) acc. to ASME B1.20.1. • Butt welding ends acc. to ASME B16.25. • End to End acc. to manufacturer standard. • Body-Bonnet weld acc. to ASME IX.

DESIGN TYPE W1

HANDWHEEL OPERATED AND V-GROOVE SEAL WELD BODY-BONNET CONNECTION

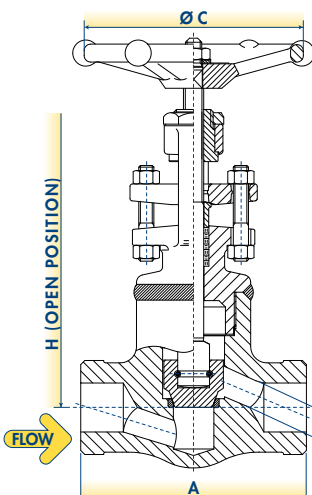

DESIGN TYPE W2

HANDWHEEL OPERATED AND TEE JOINT FILLED WELD BODY-BONNET CONNECTION

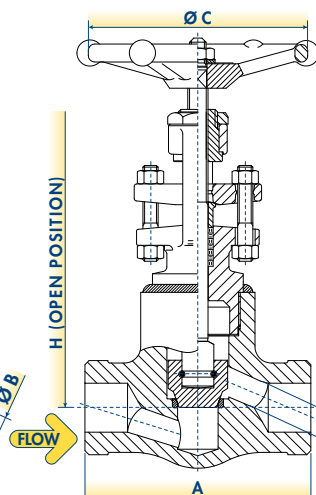

DESIGN TYPE W4

GEAR OPERATED AND TEE JOINT FILLED WELD BODY-BONNET CONNECTION

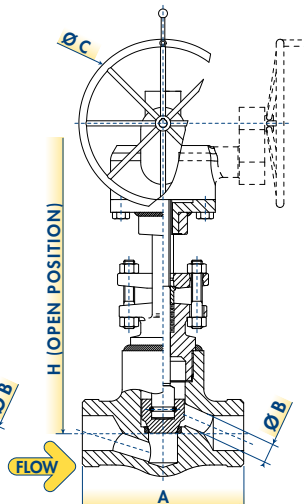

OTHER END CONNECTION TYPES AVAILABLE

INTEGRAL BUTT WELDING END

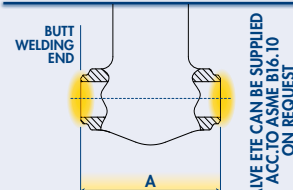

VALVE EYE CAN BE SUPPLIED ACC. TO ASME B16.10 ON REQUEST

WELDED NIPPLES

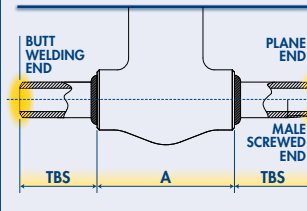

"T"-PATTERN GLOBE VALVES

WELDED BONNET GLOBE VALVES BASIC CONFIGURATION ASME INTEGRAL FLANGED ENDS



WORKING PRESSURE RATING	SIZE		STANDARD DESIGN TYPE	A-RF		A-RJ		B		C		H		WEIGHT		FIGURE
	NPS	DN		mm	in	mm	in	mm	in	mm	in	mm	in	kg	lb	
ASME 150	1/2"	15	W3	108	4.25	N.A.	N.A.	10	0.39	88	3.5	196	7.7	2.5	5.5	1HWL 303
	3/4"	20	W3	117.5	4.63	N.A.	N.A.	14	0.55	88	3.5	196	7.7	3.2	7.0	1HWL 304
	1"	25	W3	127	5.00	140	5.50	17	0.66	97	3.8	226	8.9	4.6	10.1	1HWL 305
	1-1/2"	40	W3	165	6.50	178	7.00	29	1.14	138	5.4	273	10.7	8.6	18.9	1HWL 307
	2"	50	W3	203	7.99	216	8.49	35	1.38	172	6.8	300	11.8	13.2	29.0	1HWL 308
ASME 300	1/2"	15	W3	152.5	6.00	163.5	6.44	9	0.35	88	3.5	196	7.7	3.4	7.5	3HWL 303
	3/4"	20	W3	178	7.01	190.5	7.51	13	0.51	88	3.5	202	8.0	5.0	11.0	3HWL 304
	1"	25	W3	203	7.99	216	8.49	17	0.66	97	3.8	226	8.9	6.9	15.2	3HWL 305
	1-1/2"	40	W3	229	9.02	241	9.52	29	1.14	138	5.4	270	10.6	12.9	28.5	3HWL 307
	2"	50	W3	267	10.51	282.5	11.13	35	1.38	172	6.8	321	12.6	17.9	39.5	3HWL 308
ASME 600	1/2"	15	W3	165	6.50	163.5	6.44	9	0.35	88	3.5	177	7.0	3.7	8.1	6HWL 303
	3/4"	20	W3	191	7.52	190.5	7.52	13	0.51	88	3.5	202	8.0	5.2	11.4	6HWL 304
	1"	25	W3	216	8.50	216	8.50	17	0.66	97	3.8	234	9.2	7.3	16.0	6HWL 305
	1-1/2"	40	W3	241	9.49	241	9.49	29	1.14	138	5.4	270	10.6	13.8	30.3	6HWL 307
	2"	50	W3	292	11.50	295	11.62	35	1.38	172	6.8	321	12.6	19.7	43.4	6HWL 308
ASME 1500	1/2"	15	W3	216	8.50	216	8.50	9	0.35	88	3.5	190	7.5	6.3	14.0	15HWLF 303
	3/4"	20	W3	229	9.02	229	9.02	14	0.55	97	3.8	230	9.1	9.7	21.3	15HWLF 304
	1"	25	W3	254	10.00	254	10.00	14	0.55	138	5.4	270	10.6	12.8	28.1	15HWLF 305
	1-1/2"	40	W3	305	12.01	305	12.01	26	1.02	172	6.8	315	12.4	28.5	62.8	15HWLF 307
	2"	50	W3	368	14.49	371.5	14.61	34	1.34	172	6.8	355	14.0	43.5	95.9	15HWLF 308
ASME 150	1/2"	15	W3	108	4.25	N.A.	N.A.	13	0.51	88	3.5	196	7.7	3.2	7.0	1HW 303
	3/4"	20	W3	117.5	4.63	N.A.	N.A.	17.5	0.69	97	3.8	230	9.1	5.3	11.8	1HW 304
	1"	25	W3	127	5.00	140	5.50	22.5	0.89	138	5.4	268	10.6	7.3	16.0	1HW 305
	1-1/2"	40	W3	165	6.50	178	7.00	35	1.38	172	6.8	315	12.4	13.8	30.3	1HW 307
	2"	50	W3	203	7.99	216	8.49	45	1.77	172	6.8	335	13.2	20.8	45.9	1HW 308
ASME 300	1/2"	15	W3	152.5	6.00	163.5	6.44	13	0.51	88	3.5	196	7.7	3.4	7.5	3HW 303
	3/4"	20	W3	178	7.01	190.5	7.51	17.5	0.69	97	3.8	230	9.1	5.8	12.9	3HW 304
	1"	25	W3	203	7.99	216	8.49	22.5	0.89	138	5.4	268	10.6	8.1	17.8	3HW 305
	1-1/2"	40	W3	229	9.02	241	9.52	35	1.38	172	6.8	315	12.4	15.4	34.0	3HW 307
	2"	50	W3	267	10.51	282.5	11.13	45	1.77	172	6.8	335	13.2	23.3	51.4	3HW 308
ASME 600	1/2"	15	W3	165	6.50	163.5	6.44	13	0.51	88	3.5	196	7.7	4.9	10.8	6HW 303
	3/4"	20	W3	191	7.52	190.5	7.52	17.5	0.69	97	3.8	230	9.1	6.7	14.7	6HW 304
	1"	25	W3	216	8.50	216	8.50	22.5	0.89	138	5.4	268	10.6	8.8	19.3	6HW 305
	1-1/2"	40	W3	241	9.49	241	9.49	35	1.38	172	6.8	315	12.4	16.3	35.8	6HW 307
	2"	50	W3	292	11.50	295	11.62	45	1.77	172	6.8	370	14.6	23.8	52.4	6HW 308
ASME 1500	1/2"	15	W3	216	8.50	216	8.50	12	0.47	97	3.8	240	9.4	7.1	15.6	15HWF 303
	3/4"	20	W3	229	9.02	229	9.02	14.5	0.57	138	5.4	280	11.0	10.8	23.7	15HWF 304
	1"	25	W3	254	10.00	254	10.00	19	0.75	172	6.8	295	11.6	14.2	31.2	15HWF 305
	1-1/2"	40	W3	305	12.01	305	12.01	31	1.22	172	6.8	370	14.6	25.0	55.1	15HWF 307
	2"	50	W3	368	14.49	371.5	14.61	38	1.50	234	9.2	465	18.3	48.3	106.6	15HWF 308
ASME 2500	1/2"	15	W3	264	10.39	264	10.39	11	0.43	138	5.4	310	12.2	13.8	30.3	25HWF 303
	3/4"	20	W3	273	10.75	273	10.75	14.5	0.57	138	5.4	315	12.4	15.4	34.0	25HWF 304
	1"	25	W3	308	12.13	308	12.13	19	0.75	172	6.8	350	13.8	25.0	55.1	25HWF 305
	1-1/2"	40	W3	384	15.12	387	15.24	28	1.10	234	9.2	450	17.7	51.3	113.0	25HWF 307
	2"	50	W3	451	17.76	454	17.88	38	1.50	320	12.6	460	18.1	55.8	123.1	25HWF 308

STANDARD BORE

FULL BORE

BFC reserves the right to change designs, dimensions or specifications without notice.

PRODUCT FEATURES:

- Flanged ends acc.to ASME B16.5. • Face to Face acc.to ASME B16.10. • Body-Bonnet weld acc.to ASME IX.

DESIGN TYPE W3

FULL PENETRATION WELD BODY-BONNET CONNECTION

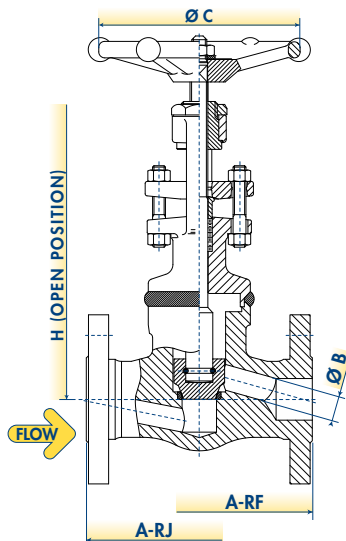

"T"-PATTERN GLOBE VALVES

WELDED BONNET GLOBE VALVES CRYOGENIC CONFIGURATION THREADED AND SOCKET WELD ENDS



WORKING PRESSURE RATING	SIZE		STANDARD DESIGN TYPE	A		B		C		H		WEIGHT		FIGURE
	NPS	DN		mm	in	mm	in	mm	in	mm	in	kg	lb	
ASME 800	1/2"	15	W1	80	3.15	9	0.35	88	3.5	420	16.5	2.6	5.6	CWL 303
	3/4"	20	W1	90	3.54	13	0.51	88	3.5	425	16.7	3.0	6.6	CWL 304
	1"	25	W1	110	4.33	17	0.66	97	3.8	467	18.4	4.5	9.9	CWL 305
	1-1/2"	40	W1	150	5.91	29	1.14	138	5.4	512	20.2	9.9	21.8	CWL 307
	2"	50	W1	180	7.09	35	1.38	172	6.8	554	21.8	15.6	34.4	CWL 308
ASME 1500	1/2"	15	W1	90	3.54	9	0.35	88	3.5	420	16.5	3.0	6.6	9CWL 303
	3/4"	20	W1	110	4.33	12	0.47	97	3.8	464	18.3	5.3	11.6	9CWL 304
	1"	25	W1	127	5.00	15	0.59	138	5.4	501	19.7	8.3	18.2	9CWL 305
	1-1/2"	40	W1	180	7.09	27	1.06	172	6.8	554	21.8	18.0	39.7	9CWL 307
	2"	50	W1	210	8.27	32	1.26	172	6.8	629	24.8	28.5	62.8	9CWL 308
ASME 800	1/4"	6	W1	80	3.15	7	0.28	88	3.5	420	16.5	2.6	5.6	CW 301
	3/8"	10	W1	80	3.15	9	0.35	88	3.5	420	16.5	2.7	6.0	CW 302
	1/2"	15	W1	90	3.54	13	0.51	88	3.5	425	16.7	3.0	6.6	CW 303
	3/4"	20	W1	110	4.33	17	0.66	97	3.8	467	18.4	4.5	9.9	CW 304
	1"	25	W1	127	5.00	22	0.86	138	5.4	501	19.7	7.5	16.5	CW 305
	1-1/4"	32	W1	150	5.91	29	1.14	138	5.4	512	20.2	10.2	22.5	CW 306
	1-1/2"	40	W1	180	7.09	35	1.38	172	6.8	554	21.8	16.5	36.4	CW 307
2"	50	W1	210	8.27	45	1.77	172	6.8	629	24.8	24.8	54.6	CW 308	
ASME 1500	1/4"	6	W1	90	3.54	7	0.28	88	3.5	420	16.5	3.3	7.3	9CW 301
	3/8"	10	W1	90	3.54	9	0.35	88	3.5	420	16.5	3.3	7.3	9CW 302
	1/2"	15	W1	110	4.33	12	0.47	97	3.8	464	18.3	5.3	11.6	9CW 303
	3/4"	20	W1	127	5.00	15	0.59	138	5.4	501	19.7	8.3	18.2	9CW 304
	1"	25	W1	150	5.91	20	0.79	138	5.4	510	20.1	11.4	25.1	9CW 305
	1-1/4"	32	W1	180	7.09	27	1.06	172	6.8	554	21.8	15.0	33.1	9CW 306
	1-1/2"	40	W1	210	8.27	32	1.26	172	6.8	629	24.8	30.0	66.1	9CW 307
2"	50	W1	210	8.27	43	1.69	234	9.2	682	26.9	45.0	99.2	9CW 308	
ASME 2500	1/4"	6	W2	90	3.54	7	0.28	88	3.5	444	17.5	6.8	14.9	25CW 301
	3/8"	10	W2	90	3.54	9	0.35	88	3.5	444	17.5	7.1	15.5	25CW 302
	1/2"	15	W2	110	4.33	11	0.43	138	5.4	480	18.9	8.3	18.2	25CW 303
	3/4"	20	W2	127	5.00	14.5	0.57	138	5.4	501	19.7	12.0	26.5	25CW 304
	1"	25	W2	180	7.09	19	0.75	138	5.4	542	21.3	19.5	43.0	25CW 305
	1-1/4"	32	W2	180	7.09	26	1.02	138	5.4	542	21.3	19.5	43.0	25CW 306
	1-1/2"	40	W2	210	8.27	29	1.14	172	6.8	614	24.2	29.7	65.5	25CW 307
2"	50	W2	230	9.06	38	1.50	234	9.2	674	26.5	45.0	99.2	25CW 308	
ASME 4500	1/4"	6	W2	127	5.00	7	0.28	138	5.4	484	19.1	9.8	21.5	45CW 301
	3/8"	10	W2	127	5.00	7	0.28	138	5.4	484	19.1	9.8	21.5	45CW 302
	1/2"	15	W2	127	5.00	8	0.31	138	5.4	489	19.3	9.8	21.5	45CW 303
	3/4"	20	W2	180	7.09	11	0.43	172	6.8	554	21.8	22.5	49.6	45CW 304
	1"	25	W2	180	7.09	14	0.55	172	6.8	554	21.8	22.5	49.6	45CW 305
	1-1/2"	40	W2	230	9.06	25	0.98	234	9.2	624	24.6	37.5	82.7	45CW 307
	2"	50	W4	230	9.06	32	1.26	400	15.7	654	25.7	45.0	99.2	45CW 308

STANDARD BORE

FULL BORE

B/E reserves the right to change designs, dimensions or specifications without notice.

PRODUCT FEATURES:

- Socket Weld acc. to ASME B16.11. • Screwed ends (NPT) acc. to ASME B1.20.1. • Butt welding ends acc. to ASME B16.25. • End to End acc. to manufacturer standard. • Cryogenic design acc. to BS 6364. • Body-Bonnet weld acc. to ASME IX.

DESIGN TYPE W1 V-GROOVE SEAL WELD BODY-BONNET CONNECTION

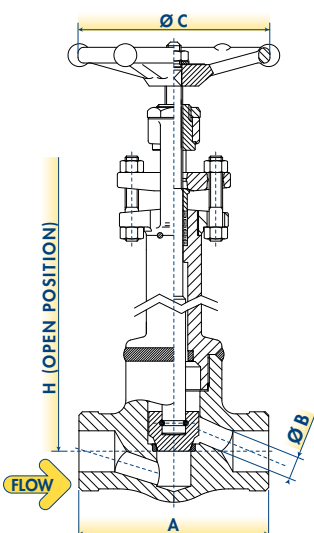

DESIGN TYPE W2 TEE JOINT FILLET WELD BODY-BONNET CONNECTION

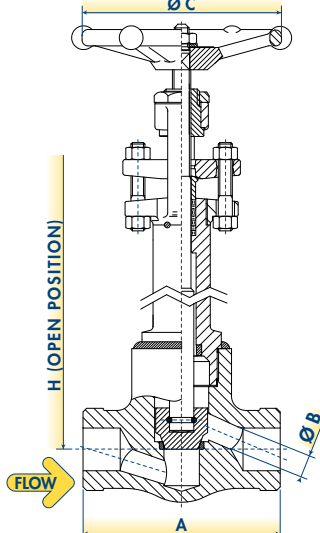

DESIGN TYPE W4 GEAR OPERATED & TEE JOINT FILLET WELD BODY-BONNET CONNECTION

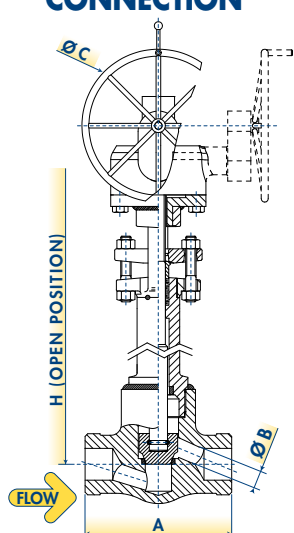

OTHER END CONNECTION TYPES AVAILABLE

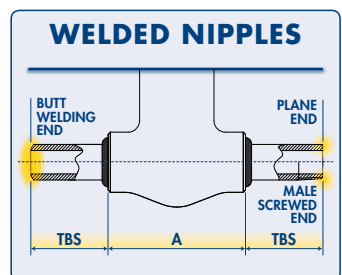
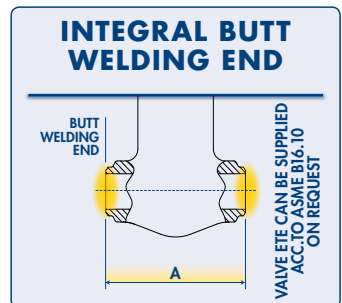

"T"-PATTERN GLOBE VALVES

WELDED BONNET GLOBE VALVES CRYOGENIC CONFIGURATION ASME INTEGRAL FLANGED ENDS



WORKING PRESSURE RATING	SIZE		STANDARD DESIGN TYPE	A-RF		A-RJ		B		C		H		WEIGHT		FIGURE
	NPS	DN		mm	in	mm	in	mm	in	mm	in	mm	in	kg	lb	
ASME 150	1/2"	15	W3	108	4.25	N.A.	N.A.	10	0.39	88	3.5	450	17.7	3.8	8.3	1CHWL 303
	3/4"	20	W3	117.5	4.63	N.A.	N.A.	14	0.55	88	3.5	450	17.7	4.8	10.5	1CHWL 304
	1"	25	W3	127	5.00	140	5.50	17	0.66	97	3.8	480	18.9	6.9	15.2	1CHWL 305
	1-1/2"	40	W3	165	6.50	178	7.00	29	1.14	138	5.4	527	20.7	12.9	28.4	1CHWL 307
	2"	50	W3	203	7.99	216	8.49	35	1.38	172	6.8	554	21.8	19.8	43.5	1CHWL 308
ASME 300	1/2"	15	W3	152.5	6.00	163.5	6.44	9	0.35	88	3.5	450	17.7	5.1	11.3	3CHWL 303
	3/4"	20	W3	178	7.01	190.5	7.51	13	0.51	88	3.5	456	18.0	7.5	16.5	3CHWL 304
	1"	25	W3	203	7.99	216	8.49	17	0.66	97	3.8	480	18.9	10.4	22.9	3CHWL 305
	1-1/2"	40	W3	229	9.02	241	9.52	29	1.14	138	5.4	524	20.6	19.4	42.7	3CHWL 307
	2"	50	W3	267	10.51	282.5	11.13	35	1.38	172	6.8	575	22.6	26.9	59.2	3CHWL 308
ASME 600	1/2"	15	W3	165	6.50	163.5	6.44	9	0.35	88	3.5	431	17.0	5.5	12.1	6CHWL 303
	3/4"	20	W3	191	7.52	190.5	7.52	13	0.51	88	3.5	456	18.0	7.8	17.1	6CHWL 304
	1"	25	W3	216	8.50	216	8.50	17	0.66	97	3.8	488	19.2	10.9	24.0	6CHWL 305
	1-1/2"	40	W3	241	9.49	241	9.49	29	1.14	138	5.4	524	20.6	20.6	45.5	6CHWL 307
	2"	50	W3	292	11.50	295	11.62	35	1.38	172	6.8	575	22.6	29.5	65.0	6CHWL 308
ASME 1500	1/2"	15	W3	216	8.50	216	8.50	9	0.35	88	3.5	444	17.5	9.5	20.9	15CHWLF 303
	3/4"	20	W3	229	9.02	229	9.02	14	0.55	97	3.8	484	19.1	14.5	32.0	15CHWLF 304
	1"	25	W3	254	10.00	254	10.00	14	0.55	138	5.4	524	20.6	19.1	42.2	15CHWLF 305
	1-1/2"	40	W3	305	12.01	305	12.01	26	1.02	172	6.8	569	22.4	42.8	94.2	15CHWLF 307
	2"	50	W3	368	14.49	371.5	14.61	34	1.34	172	6.8	609	24.0	65.3	143.9	15CHWLF 308
ASME 150	1/2"	15	W3	108	4.25	N.A.	N.A.	13	0.51	88	3.5	450	17.7	4.8	10.5	1CHW 303
	3/4"	20	W3	117.5	4.63	N.A.	N.A.	17.5	0.69	97	3.8	484	19.1	8.0	17.6	1CHW 304
	1"	25	W3	127	5.00	140	5.50	22.5	0.89	138	5.4	522	20.6	10.9	24.0	1CHW 305
	1-1/2"	40	W3	165	6.50	178	7.00	35	1.38	172	6.8	569	22.4	20.6	45.5	1CHW 307
	2"	50	W3	203	7.99	216	8.49	45	1.77	172	6.8	589	23.2	31.3	68.9	1CHW 308
ASME 300	1/2"	15	W3	152.5	6.00	163.5	6.44	13	0.51	88	3.5	450	17.7	5.1	11.3	3CHW 303
	3/4"	20	W3	178	7.01	190.5	7.51	17.5	0.69	97	3.8	484	19.1	8.8	19.3	3CHW 304
	1"	25	W3	203	7.99	216	8.49	22.5	0.89	138	5.4	522	20.6	12.1	26.7	3CHW 305
	1-1/2"	40	W3	229	9.02	241	9.52	35	1.38	172	6.8	569	22.4	23.1	51.0	3CHW 307
	2"	50	W3	267	10.51	282.5	11.13	45	1.77	172	6.8	589	23.2	35.0	77.2	3CHW 308
ASME 600	1/2"	15	W3	165	6.50	163.5	6.44	13	0.51	88	3.5	450	17.7	7.4	16.3	6CHW 303
	3/4"	20	W3	191	7.52	190.5	7.52	17.5	0.69	97	3.8	484	19.1	10.0	22.0	6CHW 304
	1"	25	W3	216	8.50	216	8.50	22.5	0.89	138	5.4	522	20.6	13.1	28.9	6CHW 305
	1-1/2"	40	W3	241	9.49	241	9.49	35	1.38	172	6.8	569	22.4	24.4	53.7	6CHW 307
	2"	50	W3	292	11.50	295	11.62	45	1.77	172	6.8	624	24.6	35.6	78.5	6CHW 308
ASME 1500	1/2"	15	W3	216	8.50	216	8.50	12	0.47	97	3.8	494	19.4	10.6	23.4	15CHWF 303
	3/4"	20	W3	229	9.02	229	9.02	14.5	0.57	138	5.4	534	21.0	16.1	35.5	15CHWF 304
	1"	25	W3	254	10.00	254	10.00	19	0.75	172	6.8	549	21.6	21.3	46.8	15CHWF 305
	1-1/2"	40	W3	305	12.01	305	12.01	31	1.22	172	6.8	624	24.6	37.5	82.7	15CHWF 307
	2"	50	W3	368	14.49	371.5	14.61	38	1.50	234	9.2	719	28.3	72.5	159.8	15CHWF 308
ASME 2500	1/2"	15	W3	264	10.39	264	10.39	11	0.43	138	5.4	564	22.2	20.6	45.5	25CHWF 303
	3/4"	20	W3	273	10.75	273	10.75	14.5	0.57	138	5.4	569	22.4	23.1	51.0	25CHWF 304
	1"	25	W3	308	12.13	308	12.13	19	0.75	172	6.8	604	23.8	37.5	82.7	25CHWF 305
	1-1/2"	40	W3	384	15.12	387	15.24	28	1.10	234	9.2	704	27.7	76.9	169.5	25CHWF 307
	2"	50	W3	451	17.76	454	17.88	38	1.50	320	12.6	714	28.1	83.8	184.6	25CHWF 308

STANDARD BORE

FULL BORE

BFE reserves the right to change designs, dimensions or specifications without notice.

PRODUCT FEATURES:

- Flanged ends acc.to ASME B16.5. • Face to Face acc.to ASME B16.10. • Cryogenic design acc.to BS 6364. • Body-Bonnet weld acc.to ASME IX.

DESIGN TYPE W3

FULL PENETRATION WELD BODY-BONNET CONNECTION

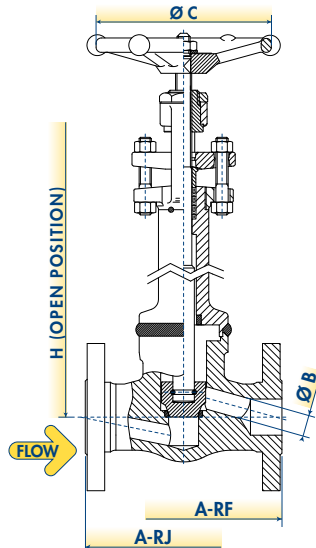

"T"-PATTERN GLOBE VALVES

WELDED BONNET GLOBE VALVES BELLOW SEAL CONFIGURATION THREADED AND SOCKET WELD ENDS



WORKING PRESSURE RATING	SIZE		STANDARD DESIGN TYPE	A		B		C		H		WEIGHT		FIGURE
	NPS	DN		mm	in	mm	in	mm	in	mm	in	kg	lb	
ASME 800	1/2"	15	P1	80	3.15	9	0.35	88	3.5	190	7.5	2.2	4.9	SHWL 303
	3/4"	20	P1	90	3.54	13	0.51	88	3.5	195	7.7	2.4	5.3	SHWL 304
	1"	25	P1	110	4.33	17	0.66	97	3.8	225	8.9	3.5	7.7	SHWL 305
	1-1/2"	40	P1	150	5.91	29	1.14	138	5.4	315	12.4	8.1	17.9	SHWL 307
	2"	50	P1	180	7.09	35	1.38	172	6.8	356	14.0	11.8	26.0	SHWL 308
ASME 1500	1/2"	15	P1	90	3.54	9	0.35	138	5.4	229	9.0	3	6.6	9SHWL 303
	3/4"	20	P1	110	4.33	12	0.47	138	5.4	243	9.6	4.6	10.1	9SHWL 304
	1"	25	P1	127	5.00	15	0.59	172	6.8	286	11.3	6.5	14.3	9SHWL 305
	1-1/2"	40	P1	180	7.09	27	1.06	234	9.2	360	14.2	12	26.5	9SHWL 307
	2"	50	P1	210	8.27	32	1.26	320	12.6	445	17.5	21.5	47.4	9SHWL 308
ASME 800	1/4"	6	P1	80	3.15	7	0.28	88	3.5	190	7.5	2.3	5.1	SHW 301
	3/8"	10	P1	80	3.15	9	0.35	88	3.5	190	7.5	2.3	5.1	SHW 302
	1/2"	15	P1	90	3.54	13	0.51	88	3.5	195	7.7	3.2	7.1	SHW 303
	3/4"	20	P1	110	4.33	17	0.66	97	3.8	225	8.9	5	11.0	SHW 304
	1"	25	P1	127	5.00	22	0.88	138	5.4	271	10.7	8	17.6	SHW 305
	1-1/4"	32	P1	150	5.91	29	1.14	138	5.4	315	12.4	9	19.8	SHW 306
	1-1/2"	40	P1	180	7.09	35	1.38	172	6.8	356	14.0	17	37.5	SHW 307
	2"	50	P1	210	8.27	45	1.77	172	6.8	429	16.9	28	61.7	SHW 308
ASME 1500	1/4"	6	P1	90	3.54	7	0.28	97	3.8	190	7.5	3.2	7.1	9SHW 301
	3/8"	10	P1	90	3.54	9	0.35	97	3.8	190	7.5	3.2	7.1	9SHW 302
	1/2"	15	P1	110	4.33	12	0.47	138	5.4	243	9.6	4	8.8	9SHW 303
	3/4"	20	P1	127	5.00	15	0.59	172	6.8	286	11.3	6.5	14.3	9SHW 304
	1"	25	P1	150	5.91	20	0.79	234	9.2	311	12.2	8.3	18.3	9SHW 305
	1-1/4"	32	P1	180	7.09	27	1.06	234	9.2	350	13.8	12	26.5	9SHW 306
	1-1/2"	40	P1	210	8.27	32	1.26	320	12.6	445	17.5	22	48.5	9SHW 307
	2"	50	P1	230	9.06	40	1.57	320	12.6	510	20.1	36.5	80.5	9SHW 308
ASME 2500	1/2"	15	P2	127	5.00	11	0.43	172	6.8	350	13.8	7	15.4	25SHW 303
	3/4"	20	P2	150	5.91	14	0.55	234	9.2	400	15.7	10.5	23.1	25SHW 304
	1"	25	P2	180	7.09	19	0.75	320	12.6	470	18.5	17	37.5	25SHW 305
	1-1/2"	40	P2	210	8.27	28	1.10	320	12.6	530	20.9	23	50.7	25SHW 307
	2"	50	P3	230	9.06	35	1.38	400	15.7	650	25.6	45	99.2	25SHW 308

STANDARD BORE

FULL BORE

BFE reserves the right to change designs, dimensions or specifications without notice.

PRODUCT FEATURES:

- Socket Weld acc. to ASME B16.11. • Screwed ends (NPT) acc. to ASME B1.20.1. • Butt welding ends acc. to ASME B16.25. • End to End acc. to manufacturer standard. • Zero emission. • Hydroformed Bellows
- Welds acc. to ASME IX. • Grease nipple for yoke sleeve. • Emergency stuffing box as back sealing.

DESIGN TYPE P1 HANDWHEEL OPERATED

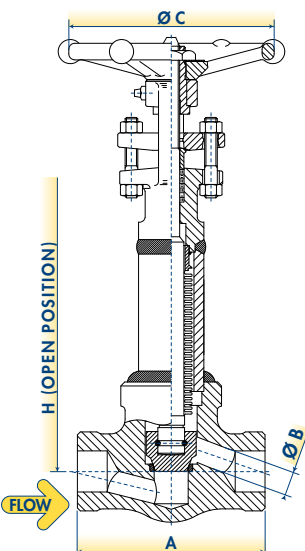

DESIGN TYPE P2 HANDWHEEL OPERATED WITH THRUST BEARINGS

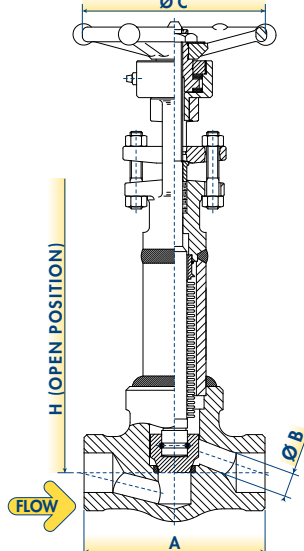

DESIGN TYPE P3 GEAR OPERATED

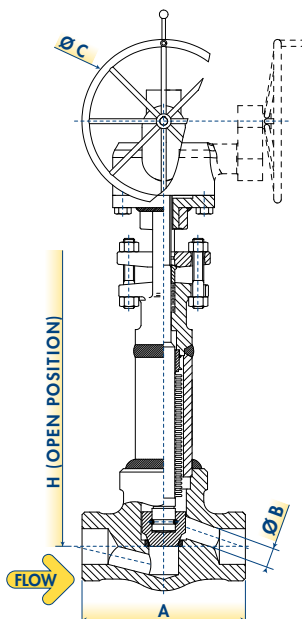

OTHER END CONNECTION TYPES AVAILABLE

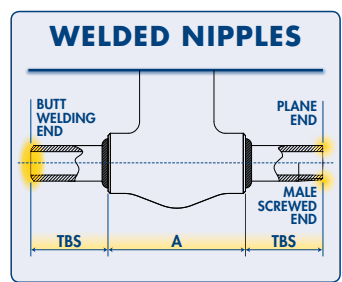
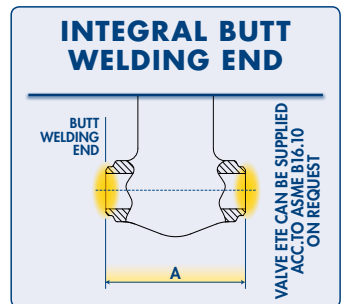

"T"-PATTERN GLOBE VALVES

WELDED BONNET GLOBE VALVES BELLOW SEAL CONFIGURATION ASME INTEGRAL FLANGED ENDS



WORKING PRESSURE RATING	SIZE		STANDARD DESIGN TYPE	A-RF		A-RJ		B		C		H		WEIGHT		FIGURE
	NPS	DN		mm	in	mm	in	mm	in	mm	in	mm	in	kg	lb	
ASME 150	1/2"	15	P1	108	4.25	N.A.	N.A.	10	0.39	88	3.5	220	8.6	3.1	6.7	1SHWL 303
	3/4"	20	P1	117.5	4.63	N.A.	N.A.	14	0.55	88	3.5	220	8.6	3.9	8.5	1SHWL 304
	1"	25	P1	127	5.00	140	5.50	17	0.66	97	3.8	253	10.0	5.6	12.3	1SHWL 305
	1-1/2"	40	P1	165	6.50	178	7.00	29	1.14	138	5.4	306	12.0	10.5	23.1	1SHWL 307
	2"	50	P1	203	7.99	216	8.49	35	1.38	138	5.4	336	13.2	16.1	35.4	1SHWL 308
ASME 300	1/2"	15	P1	152.5	6.00	163.5	6.44	9	0.35	88	3.5	220	8.6	4.2	9.2	3SHWL 303
	3/4"	20	P1	178	7.01	190.5	7.51	13	0.51	88	3.5	226	8.9	6.1	13.4	3SHWL 304
	1"	25	P1	203	7.99	216	8.49	17	0.66	97	3.8	253	10.0	8.4	18.6	3SHWL 305
	1-1/2"	40	P1	229	9.02	241	9.52	29	1.14	138	5.4	302	11.9	15.8	34.7	3SHWL 307
	2"	50	P1	267	10.51	282.5	11.13	35	1.38	138	5.4	360	14.2	21.9	48.2	3SHWL 308
ASME 600	1/2"	15	P1	165	6.50	163.5	6.44	9	0.35	88	3.5	198	7.8	4.5	9.9	6SHWL 303
	3/4"	20	P1	191	7.52	190.5	7.52	13	0.51	88	3.5	226	8.9	6.3	13.9	6SHWL 304
	1"	25	P1	216	8.50	216	8.50	17	0.66	97	3.8	262	10.3	8.8	19.5	6SHWL 305
	1-1/2"	40	P1	241	9.49	241	9.49	29	1.14	138	5.4	302	11.9	16.8	37.0	6SHWL 307
	2"	50	P1	292	11.50	295	11.62	35	1.38	138	5.4	360	14.2	24.0	52.9	6SHWL 308
ASME 1500	1/2"	15	P1	216	8.50	216	8.50	9	0.35	88	3.5	213	8.4	7.7	17.0	15SHWLF 303
	3/4"	20	P1	229	9.02	229	9.02	14	0.55	97	3.8	258	10.1	11.8	26.0	15SHWLF 304
	1"	25	P1	254	10.00	254	10.00	14	0.55	138	5.4	302	11.9	15.6	34.3	15SHWLF 305
	1-1/2"	40	P1	305	12.01	305	12.01	26	1.02	172	6.8	353	13.9	34.8	76.7	15SHWLF 307
	2"	50	P1	368	14.49	371.5	14.61	34	1.34	172	6.8	398	15.7	53.1	117.0	15SHWLF 308
ASME 150	1/2"	15	P1	108	4.25	N.A.	N.A.	13	0.51	88	3.5	220	8.6	3.9	8.5	1SHW 303
	3/4"	20	P1	117.5	4.63	N.A.	N.A.	17.5	0.69	97	3.8	258	10.1	6.5	14.3	1SHW 304
	1"	25	P1	127	5.00	140	5.50	22.5	0.89	138	5.4	300	11.8	8.8	19.5	1SHW 305
	1-1/2"	40	P1	165	6.50	178	7.00	35	1.38	172	6.8	353	13.9	16.8	37.0	1SHW 307
	2"	50	P1	203	7.99	216	8.49	45	1.77	172	6.8	375	14.8	25.4	56.0	1SHW 308
ASME 300	1/2"	15	P1	152.5	6.00	163.5	6.44	13	0.51	88	3.5	220	8.6	4.2	9.2	3SHW 303
	3/4"	20	P1	178	7.01	190.5	7.51	17.5	0.69	97	3.8	258	10.1	7.1	15.7	3SHW 304
	1"	25	P1	203	7.99	216	8.49	22.5	0.89	138	5.4	300	11.8	9.9	21.7	3SHW 305
	1-1/2"	40	P1	229	9.02	241	9.52	35	1.38	172	6.8	353	13.9	18.8	41.5	3SHW 307
	2"	50	P1	267	10.51	282.5	11.13	45	1.77	172	6.8	375	14.8	28.5	62.8	3SHW 308
ASME 600	1/2"	15	P1	165	6.50	163.5	6.44	13	0.51	88	3.5	220	8.6	6.0	13.2	6SHW 303
	3/4"	20	P1	191	7.52	190.5	7.52	17.5	0.69	97	3.8	258	10.1	8.1	17.9	6SHW 304
	1"	25	P1	216	8.50	216	8.50	22.5	0.89	138	5.4	300	11.8	10.7	23.5	6SHW 305
	1-1/2"	40	P1	241	9.49	241	9.49	35	1.38	172	6.8	353	13.9	19.8	43.7	6SHW 307
	2"	50	P1	292	11.50	295	11.62	45	1.77	172	6.8	414	16.3	29.0	63.9	6SHW 308
ASME 1500	1/2"	15	P1	216	8.50	216	8.50	12	0.47	97	3.8	269	10.6	8.6	19.1	15SHWF 303
	3/4"	20	P1	229	9.02	229	9.02	14.5	0.57	138	5.4	314	12.3	13.1	28.9	15SHWF 304
	1"	25	P1	254	10.00	254	10.00	19	0.75	172	6.8	330	13.0	17.3	38.1	15SHWF 305
	1-1/2"	40	P1	305	12.01	305	12.01	31	1.22	172	6.8	414	16.3	30.5	67.2	15SHWF 307
	2"	50	P1	368	14.49	371.5	14.61	38	1.50	234	9.2	521	20.5	59.0	130.0	15SHWF 308
ASME 2500	1/2"	15	P2	264	10.39	264	10.39	11	0.43	138	5.4	347	13.7	16.8	37.0	25SHWF 303
	3/4"	20	P2	273	10.75	273	10.75	14.5	0.57	138	5.4	353	13.9	18.8	41.5	25SHWF 304
	1"	25	P2	308	12.13	308	12.13	19	0.75	172	6.8	392	15.4	30.5	67.2	25SHWF 305
	1-1/2"	40	P2	384	15.12	387	15.24	28	1.10	234	9.2	504	19.8	62.5	137.8	25SHWF 307
	2"	50	P3	451	17.76	454	17.88	38	1.50	320	12.6	515	20.3	68.1	150.2	25SHWF 308

STANDARD BORE

FULL BORE

BFE reserves the right to change designs, dimensions or specifications without notice.

PRODUCT FEATURES:

- Flanged ends acc. to ASME B16.5. • Face to Face acc. to ASME B16.10. • Zero emission. • Hydroformed Bellows. • Welds acc. to ASME IX. • Grease nipple for yoke sleeve. • Emergency stuffing box as back sealing.

DESIGN TYPE P1

HANDWHEEL OPERATED

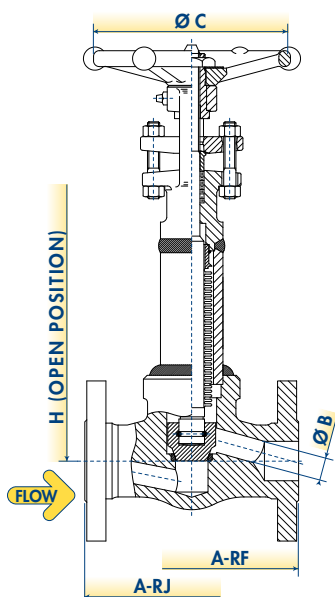

DESIGN TYPE P2

HANDWHEEL OPERATED WITH THRUST BEARINGS

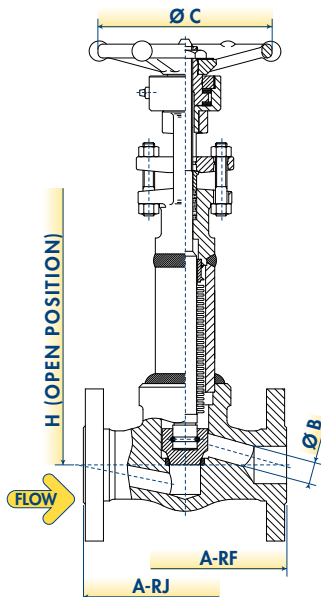

DESIGN TYPE P3

GEAR OPERATED

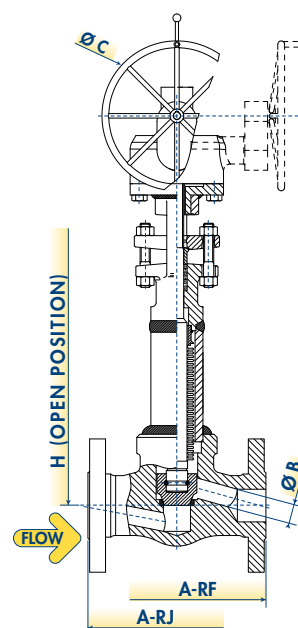

"T"-PATTERN GLOBE VALVES

AVAILABLE OPTIONS FOR "T"-PATTERN GLOBE VALVES OTHER VALVE OPTIONS OR CUSTOMISED VERSIONS ARE AVAILABLE ON REQUEST, CONTACT BFE FOR SPECIAL REQUIREMENTS.

STEM EXTENSION

Valve handle can be extended to allow for panel mount and pipe insulation.

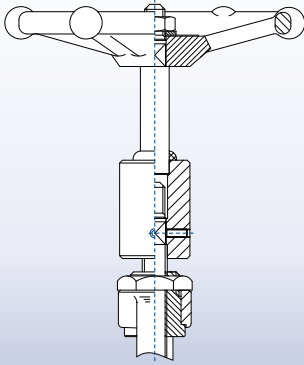

BEVEL GEAR OPERATOR

Gearing can be applied to valves instead of the standard handwheel to make operation easier.

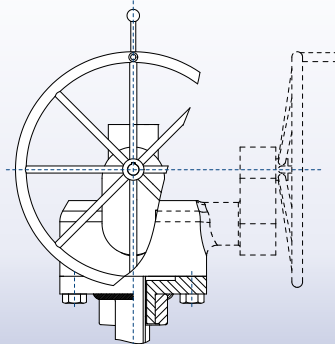

POSITION INDICATOR

Valves can be supplied with standard visual-mechanical indicating device that also acts as stem cover.

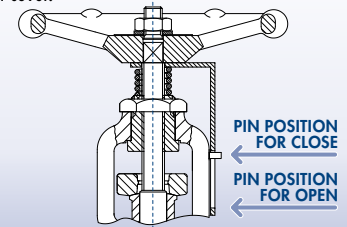

STOP CHECK

Globe valves with stop check option have a guided loose disc allowing the valve to act as a combination globe and check valve. There is the manual control to regulate the opening and closing, and can be completely stopped or shut off. This type of valve will generally be used as a globe valve to start or stop the flow of the media, but will automatically close should pressure be lost in the line, preventing backflow.

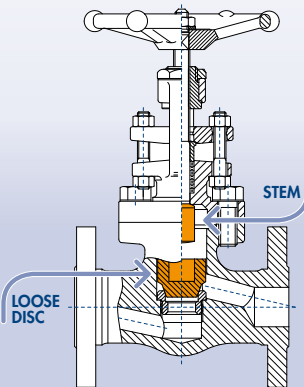

DEAD MAN OPERATOR

Dead Man Handle automatically closes the valve when operator Releases Handle. This means the operator must hold the handle in the open position for the product to flow. The operator can't walk away or the valve will shut off. Locking handle option for our spring return deadman handle is available.

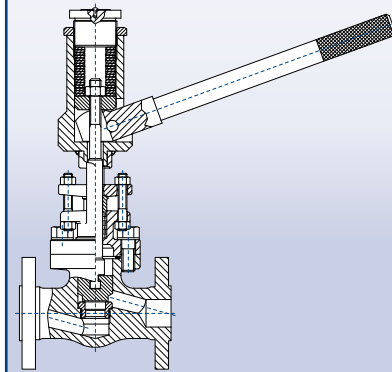

ACTUATOR-READY

Valves can be supplied ready for actuation without the handwheel or gear box. The mounting connection can be BFE Standard or can suit the choice or type of actuator.

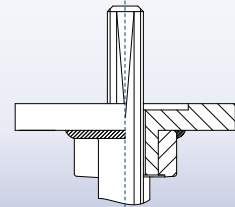

ELECTRIC, PNEUMATIC OR HYDRAULIC ACTUATORS

Motorized controls may be applied to valves of any size for operation in any position or location.

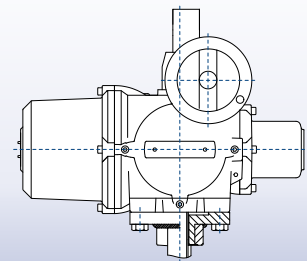

LOCKING DEVICE

Locking devices designed to help prevent accidental or unwanted operation are built to resist excessive force. All BFE locking device option are simple but secure. Chain and Padlock available on request.

LOCKING FACILITY

LOCKING FACILITY WITH C&P

LOCKING DEVICE

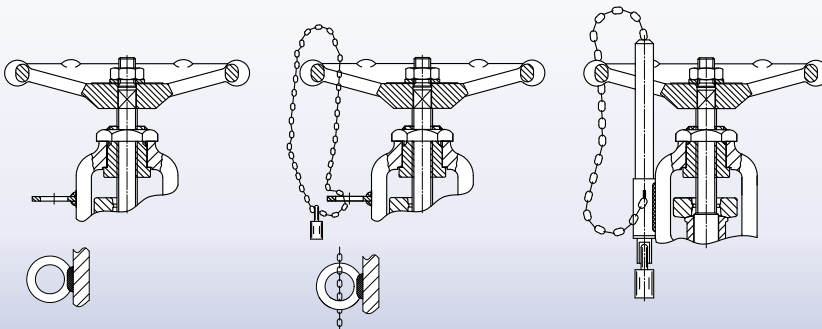

THERMAL EXPANSION STEM COMPENSATOR

Valves which endure large thermal transients have the basic problem that the valve stem and closure member will expand and contract with the danger that a closed valve could become jammed in its seat and in extreme cases this can cause the valve stem to distort. High Temperature Valve configuration is equipped with a spring loaded stem sleeve that will absorb any expansion or contraction caused by temperature fluctuations without affecting the position of the closed valve stem.

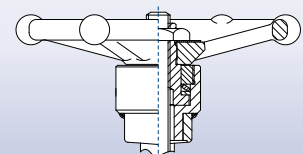

"T"-PATTERN GLOBE VALVES

AVAILABLE OPTIONS FOR "T"-PATTERN GLOBE VALVES OTHER VALVE OPTIONS OR CUSTOMISED VERSIONS ARE AVAILABLE ON REQUEST, CONTACT BFE FOR SPECIAL REQUIREMENTS.

DISC AND TRIM TYPE

BFE standard plug is the has a quick opening characteristic, this plug provides maximum flow with minimum pressure drop and is ideal when large flows are required just after opening. All BFE standard plugs require a flow direction FTO type. BFE trim variations can offer maximum versatility in flow control application within the capability of globe valve design.

PARABOLIC DISC TRIM TYPE

Characteristic: Linear. This plug covers all Cv ranges and is especially suitable for low differential pressures.

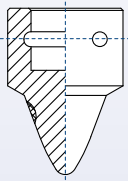

NEEDLE TRIM TYPE

Needle trim design is suitable for use where low valve CV values or low flows are required.

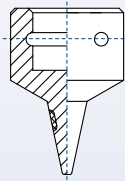

BLOW DOWN TRIM STANDARD TYPE

Blow Down trim design is suitable for use where high differential pressures are present. The high pressure drop causes erosion and cavitation which can destroy conventional globe valves.

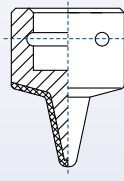

BLOW DOWN TRIM MULTI-STEP TYPE

Improved blow-down trim developed to provide a high number of pressure letdown steps to minimise the potential for excessive noise, cavitation, vibration and erosion. Multi-Step trim has been designed for all fluid combinations, both clean and dirty service. This range of trims is normally customized and designed on the customer design data.

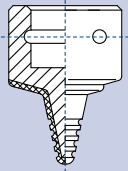

BALL DISC TRIM TYPE

The ball disc is used where the applications involve low pressure and low temperature systems. Though the ball disc can be used for throttling purpose, the efficiency might not be as expected.

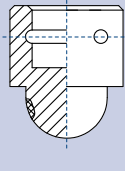

SOFT SEATED PLUG

Soft seated trim provides improved seat tightness at low differential pressures. This design feature includes a plastic sealing member on the valve closure element to supplement the basic metal-to-metal seating function. The design and material selection for these sealing members are based on customer pressure, temperature and compatibility with the line fluid.

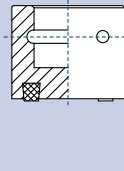

SPECIAL END FINISH

The choice of end connections for connecting a valve to its associated pipe is performed by costumers. Common end finish steated in the catalogue are socket, threaded, flanged (RF or RJ) and butt-weld ends. BFE is basically able to perform any end finish as required by the customers and other end finish as follows: hub, compact flange, any ASME B16.5 end finish other than RF and RJ, etc.

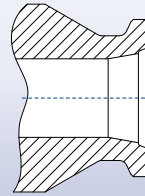

LIMIT SWITCH ASSEMBLIES

Position Limit Switch assemblies enables a remote signaling of the control system the opening of the valve. It can be equipped with one or two switches actuated by closing or opening of the valve. Limit switch can be selected by customer, bracket is designed by BFE.

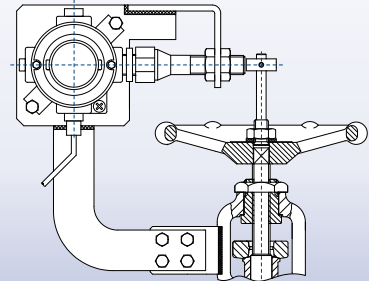

STEM DOUBLE SEAL

Stem double seals are fitted to valves when hazardous fluids are handled or when external lubrication is used.

The most usual form of double seal is two sets of packing, the lantern ring can provide extra stem guidance.

BFE can supply the lantern ring version with standard plug or with injector (double ball check type). Other special configurations are available on request.

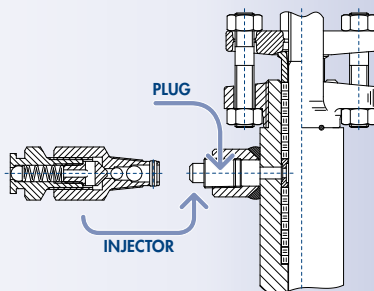

BODY-BONNET FULL PENETRATION WELD

BFE standard welded bonnet valves have as standard a seal weld on the body-bonnet connection. Seal weld is a weld that does not contribute anything to the mechanical integrity of an assembly, but is made purely to seal or prevent leakage from, for instance, a threaded joint. When High-End quality is required for body-bonnet weld joint a weld with full penetration can be performed.

Full penetration weld is one in which there is a complete penetration and fusion of weld and parent metal throughout the thickness of the joint. A full penetration weld ensures a fully welded interface between the two parts and is generally the strongest joint.

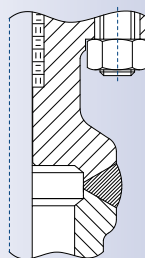

LIVE LOADING

Live Loading System consists of a spring system installed on packing stud to warrant a continuous load on valve packing. Spring are specially designed to allow appropriate load in case of packing settling by minimizing initial load and friction. Mechanical visual indicator of the spring compression is included.

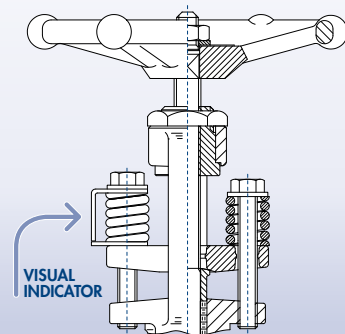

"Y"-PATTERN GLOBE VALVES



Low operation torque design.

Rising and rotating stem for the most API 602 design simplicity.

Outside Screw and Yoke (OS&Y).

Flanged valves are provided with flanges integral with the body forgings.

Standard construction of body-bonnet connections is welded bonnet type. Bolted bonnet is available as alternative construction.

Full die forged structure for all pressure containing parts.

Pattern designed to reduce the flow resistance of the valve to a minimum.

Self aligning two piece packing gland.

The connection wire secures the disc to the stem, the disc can swivel in order to guarantee the complete contact between the disc and seats surfaces.

High quality packing for reliable tightness and low emission performance.

Back-seat design.

High flow capacity port sizes and disc retraction to minimize flow velocities and maximize valve service life.

Body-guided disc for perfect seat and disc alignment. Disc is machined to the tightest tolerances to ensure trouble free shutoff and cycling.

Standard seat design is integral type, screwed-in type is available as alternative construction or in case of bolted bonnet design. Extra thickness of the seat ring provides sufficient material to renew the seating surface over and over again.

GLOBE "Y"-PATTERN VALVE DESCRIPTION

Globe valves are used for flow regulation, frequent operation, increased flow resistance or for positive shutoff when closed. Globe valves are closing-down valves in which the closure member is moved squarely on and off the seat. By this mode of disc travel, the seat opening varies in direct proportion to the travel of the disc. This proportional relationship between valve opening and disc travel is ideally suited for duties involving regulation of flow rate. Globe valves can also be used for on-off duty, the seating load can be positively controlled with high sealing capacity.

The change in direction of fluid flow through these valves produces increased resistance and pressure drop. The oblique pattern globe-valve body is designed to reduce the flow resistance of the valve to a minimum. This valve combines low flow resistance for on-off duty with the robustness of globe-valve seatings. Globe valves are used in many industrial applications including the oil and gas industry, pharmaceutical, manufacturing, automotive, and marine. Globe valves are also recommended for services requiring frequent operation and positive shutoff.





P&ID SYMBOL









STANDARD CONFIGURATIONS



SECTION INDEX OF "Y"-PATTERN GLOBE VALVES

PAGE	DESCRIPTION	SYM
D-3	BOLTED BONNET GLOBE VALVES BASIC CONFIGURATION THREADED AND SOCKET WELD ENDS	
D-4	BOLTED BONNET GLOBE VALVES BASIC CONFIGURATION ASME INTEGRAL FLANGED ENDS	
D-5	BOLTED BONNET GLOBE VALVES CRYOGENIC CONFIGURATION THREADED AND SOCKET WELD ENDS	
D-6	BOLTED BONNET GLOBE VALVES CRYOGENIC CONFIGURATION ASME INTEGRAL FLANGED ENDS	
D-7	BOLTED BONNET GLOBE VALVES BELLOW SEAL CONFIGURATION THREADED AND SOCKET WELD ENDS	
D-8	BOLTED BONNET GLOBE VALVES BELLOW SEAL CONFIGURATION ASME INTEGRAL FLANGED ENDS	

PAGE	DESCRIPTION	SYM
D-9	WELDED BONNET GLOBE VALVES BASIC CONFIGURATION THREADED AND SOCKET WELD ENDS	
D-10	WELDED BONNET GLOBE VALVES BASIC CONFIGURATION ASME INTEGRAL FLANGED ENDS	
D-11	WELDED BONNET GLOBE VALVES CRYOGENIC CONFIGURATION THREADED AND SOCKET WELD ENDS	
D-12	WELDED BONNET GLOBE VALVES CRYOGENIC CONFIGURATION ASME INTEGRAL FLANGED ENDS	
D-13	WELDED BONNET GLOBE VALVES BELLOW SEAL CONFIGURATION THREADED AND SOCKET WELD ENDS	
D-14	WELDED BONNET GLOBE VALVES BELLOW SEAL CONFIGURATION ASME INTEGRAL FLANGED ENDS	
D-15	AVAILABLE OPTIONS FOR "Y" PATTERN GLOBE VALVES	

APPLICABLE STANDARDS	
DESIGN	API 602 - ISO 15761 - ASME B16.34
INSPECTION & TESTING	API 598
MARKING	MSS SP-25
RATING	ASME B16.34
FUGITIVE EMISSION	API 624 - ISO 15848

"Y"-PATTERN GLOBE VALVES

BOLTED BONNET GLOBE VALVES BASIC CONFIGURATION THREADED AND SOCKET WELD ENDS



WORKING PRESSURE RATING	SIZE		STANDARD DESIGN TYPE	A		B		C		H		WEIGHT		FIGURE
	NPS	DN		mm	in	mm	in	mm	in	mm	in	kg	lb	
ASME 800	1/4"	6	S1	85	3.35	7	0.28	88	3.5	191	7.5	2.1	4.6	YH 301
	3/8"	10	S1	85	3.35	9	0.35	88	3.5	191	7.5	2.1	4.6	YH 302
	1/2"	15	S1	152.5	6.00	13	0.51	88	3.5	191	7.5	2.1	4.6	YH 303
	3/4"	20	S1	115	4.53	17	0.67	97	3.8	237	9.3	3.5	7.6	YH 304
	1"	25	S1	135	5.31	22	0.87	138	5.4	281	11.0	5.3	11.6	YH 305
	1-1/4"	32	S1	165	6.50	29	1.14	172	6.8	281	11.0	11.6	25.5	YH 306
	1-1/2"	40	S1	229	9.02	35	1.38	172	6.8	350	13.8	11.6	25.5	YH 307
	2"	50	S1	190	7.50	45	1.77	172	6.8	413	16.2	15.8	34.7	YH 308
ASME 1500	1/4"	6	S1	85	3.35	7	0.28	88	3.5	193	7.6	2.1	4.6	9YH 301
	3/8"	10	S1	85	3.35	9	0.35	88	3.5	193	7.6	2.1	4.6	9YH 302
	1/2"	15	S1	115	4.53	12	0.47	97	3.8	237	9.3	3.7	8.1	9YH 303
	3/4"	20	S1	135	5.31	15	0.59	138	5.4	281	11.0	5.6	12.3	9YH 304
	1"	25	S1	220	8.66	20	0.79	138	5.4	308	12.1	11.6	25.5	9YH 305
	1-1/4"	32	S1	165	6.50	27	1.06	172	6.8	347	13.6	11.6	25.5	9YH 306
	1-1/2"	40	S1	245	9.65	32	1.26	172	6.8	418	16.5	17.3	38.2	9YH 307
	2"	50	S1	230	9.06	40	1.57	234	9.2	495	19.5	27.3	60.2	9YH 308
ASME 2500	1/4"	6	S2	85	3.35	7	0.28	88	3.5	242	9.5	3.7	8.1	25YHR 301
	3/8"	10	S2	85	3.35	9	0.35	88	3.5	242	9.5	3.7	8.1	25YHR 302
	1/2"	15	S2	115	4.53	11	0.43	138	5.4	264	10.4	5.3	11.6	25YHR 303
	3/4"	20	S2	145	5.71	15	0.59	138	5.4	303	11.9	12.1	26.6	25YHR 304
	1"	25	S2	210	8.27	19	0.75	172	6.8	341	13.4	13.1	28.9	25YHR 305
	1-1/4"	32	S2	165	6.50	26	1.02	172	6.8	341	13.4	13.1	28.9	25YHR 306
	1-1/2"	40	S2	230	9.06	29	1.14	234	9.2	396	15.6	17.9	39.4	25YHR 307
	2"	50	S2	220	8.66	38	1.50	320	12.6	484	19.1	27.3	60.2	25YHR 308

FULL BORE

BFE reserves the right to change designs, dimensions or specifications without notice.

PRODUCT FEATURES:

- Outside Screw and Yoke (OS&Y).
- Self aligning two piece packing gland.
- Integral backseat.

DESIGN TYPE S1 SPIRAL WOUND GASKET BODY-BONNET CONNECTION

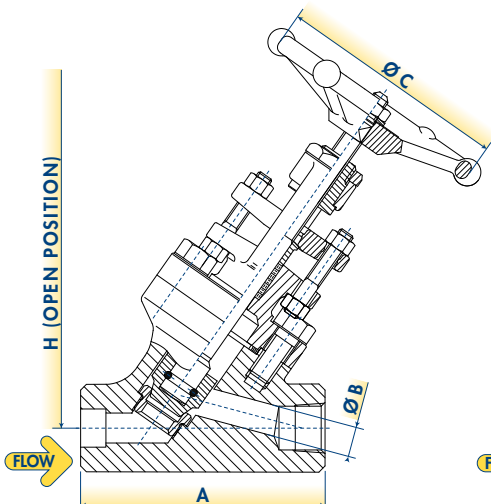

DESIGN TYPE S2 RING JOINT BODY-BONNET CONNECTION

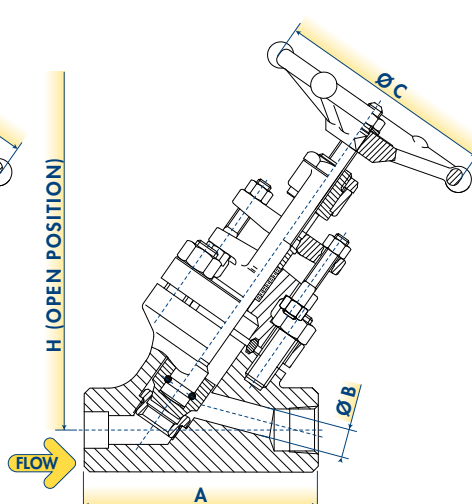

OTHER END CONNECTION TYPES AVAILABLE

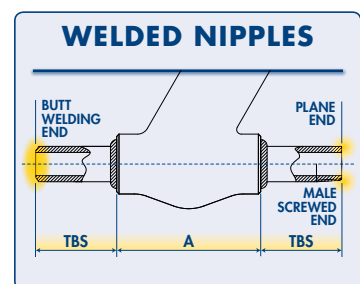
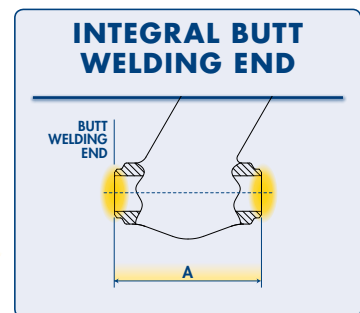

"Y"-PATTERN GLOBE VALVES

BOLTED BONNET GLOBE VALVES BASIC CONFIGURATION ASME INTEGRAL FLANGED ENDS



WORKING PRESSURE RATING	SIZE		STANDARD DESIGN TYPE	A-RF		A-RJ		B		C		H		WEIGHT		FIGURE
	NPS	DN		mm	in	mm	in	mm	in	mm	in	mm	in	kg	lb	
ASME 150 (SEE NOTE 1)	1/2"	15	S1	152.5 ⁽¹⁾	6.00	N.A.	N.A.	13	0.51	88	3.5	216	8.5	4.0	8.8	1YH 303
	3/4"	20	S1	178 ⁽¹⁾	7.01	N.A.	N.A.	17.5	0.69	97	3.8	253	10.0	6.7	14.8	1YH 304
	1"	25	S1	203 ⁽¹⁾	7.99	216 ⁽¹⁾	8.49	22.5	0.89	138	5.4	295	11.6	9.1	20.1	1YH 305
	1-1/2"	40	S1	229 ⁽¹⁾	9.02	241 ⁽¹⁾	9.52	35	1.38	172	6.8	347	13.6	17.3	38.2	1YH 307
	2"	50	S1	267 ⁽¹⁾	10.51	282.5 ⁽¹⁾	11.13	45	1.77	172	6.8	369	14.5	26.3	57.9	1YH 308
ASME 300	1/2"	15	S1	152.5	6.00	163.5	6.44	13	0.51	88	3.5	216	8.5	4.3	9.5	3YH 303
	3/4"	20	S1	178	7.01	190.5	7.51	17.5	0.69	97	3.8	253	10.0	7.4	16.2	3YH 304
	1"	25	S1	203	7.99	216	8.49	22.5	0.89	138	5.4	295	11.6	10.2	22.5	3YH 305
	1-1/2"	40	S1	229	9.02	241	9.52	35	1.38	172	6.8	347	13.6	19.4	42.8	3YH 307
	2"	50	S1	267	10.51	282.5	11.13	45	1.77	172	6.8	369	14.5	29.4	64.8	3YH 308
ASME 600	1/2"	15	S1	165	6.50	163.5	6.44	13	0.51	88	3.5	216	8.5	6.2	13.7	6YH 303
	3/4"	20	S1	191	7.52	190.5	7.52	17.5	0.69	97	3.8	253	10.0	8.4	18.5	6YH 304
	1"	25	S1	216	8.50	216	8.50	22.5	0.89	138	5.4	295	11.6	11.0	24.3	6YH 305
	1-1/2"	40	S1	241	9.49	241	9.49	35	1.38	172	6.8	347	13.6	20.5	45.1	6YH 307
	2"	50	S1	292	11.50	295	11.62	45	1.77	172	6.8	407	16.0	29.9	66.0	6YH 308
ASME 1500	1/2"	15	S1	216	8.50	216	8.50	12	0.47	97	3.8	264	10.4	8.9	19.7	15YHF 303
	3/4"	20	S1	229	9.02	229	9.02	14.5	0.57	138	5.4	308	12.1	13.5	29.9	15YHF 304
	1"	25	S1	254	10.00	254	10.00	19	0.75	172	6.8	325	12.8	17.9	39.4	15YHF 305
	1-1/2"	40	S1	305	12.01	305	12.01	31	1.22	172	6.8	407	16.0	31.5	69.4	15YHF 307
	2"	50	S1	368	14.49	371.5	14.61	38	1.50	234	9.2	512	20.1	60.9	134.3	15YHF 308
ASME 2500	1/2"	15	S2	264	10.39	264	10.39	11	0.43	138	5.4	341	13.4	17.3	38.2	25YRF 303
	3/4"	20	S2	273	10.75	273	10.75	14.5	0.57	138	5.4	347	13.6	19.4	42.8	25YRF 304
	1"	25	S2	308	12.13	308	12.13	19	0.75	172	6.8	385	15.2	31.5	69.4	25YRF 305
	1-1/2"	40	S2	384	15.12	387	15.24	28	1.10	234	9.2	495	19.5	64.6	142.4	25YRF 307
	2"	50	S2	451	17.76	454	17.88	38	1.50	320	12.6	506	19.9	70.4	155.1	25YRF 308

FULL BORE

BFE reserves the right to change designs, dimensions or specifications without notice.

PRODUCT FEATURES:

- Outside Screw and Yoke (OS&Y).
 - Self aligning two piece packing gland.
 - Integral backseat.
 - Integral body flanges.
- NOTE 1: Face-to-Face acc.to ASME B16.10 related to class 300.

DESIGN TYPE S1

SPIRAL WOUND GASKET BODY-BONNET CONNECTION

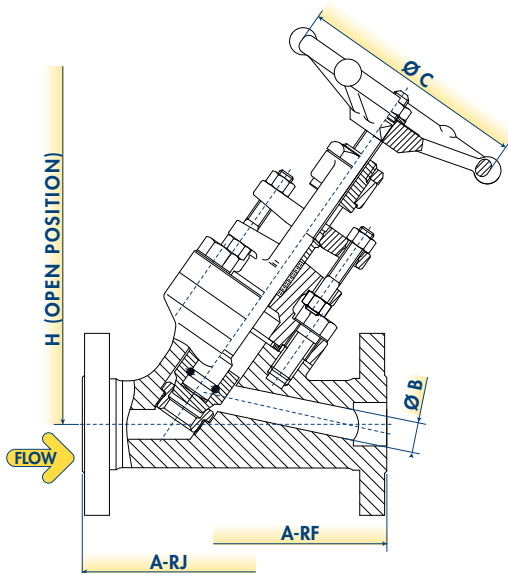

DESIGN TYPE S2

RING JOINT BODY-BONNET CONNECTION

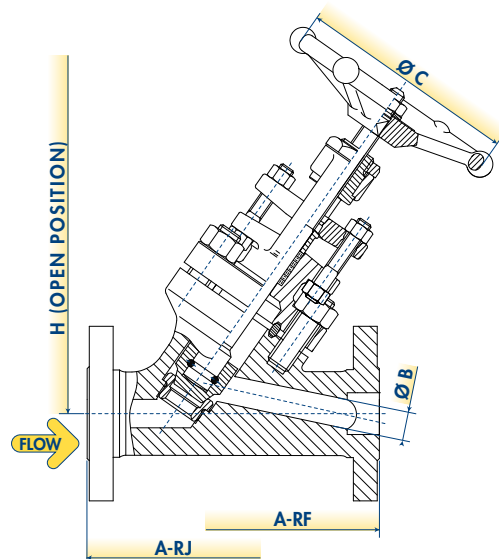

"Y"-PATTERN GLOBE VALVES

BOLTED BONNET GLOBE VALVES CRYOGENIC CONFIGURATION THREADED AND SOCKET WELD ENDS



WORKING PRESSURE RATING	SIZE		STANDARD DESIGN TYPE	A		B		C		H		WEIGHT		FIGURE
	NPS	DN		mm	in	mm	in	mm	in	mm	in	kg	lb	
ASME 800	1/4"	6	S1	85	3.35	7	0.28	88	3.5	466	18.4	3.7	8.1	CYH 301
	3/8"	10	S1	85	3.35	9	0.35	88	3.5	466	18.4	3.7	8.1	CYH 302
	1/2"	15	S1	152.5	6.00	13	0.51	88	3.5	466	18.4	3.8	8.3	CYH 303
	3/4"	20	S1	115	4.53	17	0.67	97	3.8	512	20.1	5.4	11.8	CYH 304
	1"	25	S1	135	5.31	22	0.87	138	5.4	556	21.9	8.8	19.4	CYH 305
	1-1/4"	32	S1	165	6.50	29	1.14	172	6.8	556	21.9	13.2	29.2	CYH 306
	1-1/2"	40	S1	229	9.02	35	1.38	172	6.8	625	24.6	17.3	38.2	CYH 307
	2"	50	S1	190	7.50	45	1.77	172	6.8	688	27.1	25.2	55.6	CYH 308
ASME 1500	1/4"	6	S1	85	3.35	7	0.28	88	3.5	468	18.4	4.2	9.3	9CYH 301
	3/8"	10	S1	85	3.35	9	0.35	88	3.5	468	18.4	4.2	9.3	9CYH 302
	1/2"	15	S1	115	4.53	12	0.47	97	3.8	512	20.1	5.8	12.7	9CYH 303
	3/4"	20	S1	135	5.31	15	0.59	138	5.4	556	21.9	8.4	18.5	9CYH 304
	1"	25	S1	220	8.66	20	0.79	138	5.4	583	23.0	11.6	25.5	9CYH 305
	1-1/4"	32	S1	165	6.50	27	1.06	172	6.8	622	24.5	16.3	35.9	9CYH 306
	1-1/2"	40	S1	245	9.65	32	1.26	172	6.8	693	27.3	26.3	57.9	9CYH 307
	2"	50	S1	230	9.06	40	1.57	234	9.2	770	30.3	43.1	94.9	9CYH 308
ASME 2500	1/4"	6	S2	85	3.35	7	0.28	88	3.5	517	20.4	5.8	12.7	25CYHR 301
	3/8"	10	S2	85	3.35	9	0.35	88	3.5	517	20.4	8.4	18.5	25CYHR 302
	1/2"	15	S2	115	4.53	11	0.43	138	5.4	539	21.2	13.1	28.9	25CYHR 303
	3/4"	20	S2	145	5.71	15	0.59	138	5.4	578	22.7	13.1	28.9	25CYHR 304
	1"	25	S2	210	8.27	19	0.75	172	6.8	616	24.3	27.3	60.2	25CYHR 305
	1-1/4"	32	S2	165	6.50	26	1.02	172	6.8	616	24.3	33.6	74.1	25CYHR 306
	1-1/2"	40	S2	230	9.06	29	1.14	234	9.2	671	26.4	46.2	101.9	25CYHR 307
	2"	50	S2	220	8.66	38	1.50	320	12.6	759	29.9	46.2	101.9	25CYHR 308

FULL BORE

BFE reserves the right to change designs, dimensions or specifications without notice.

PRODUCT FEATURES:

- Outside Screw and Yoke (OS&Y).
- Self aligning two piece packing gland.
- Integral backseat.

**DESIGN TYPE S1
SPIRAL WOUND GASKET
BODY-BONNET
CONNECTION**

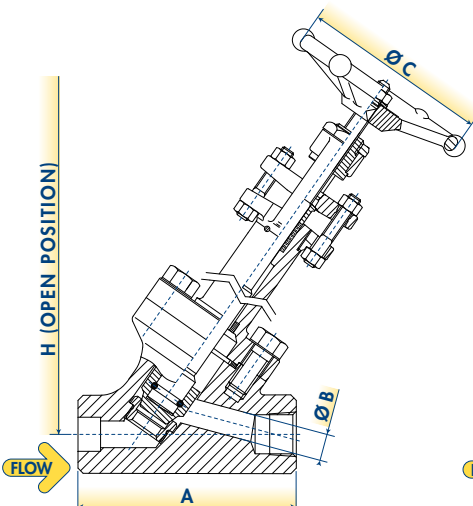

**DESIGN TYPE S2
RING JOINT
BODY-BONNET
CONNECTION**

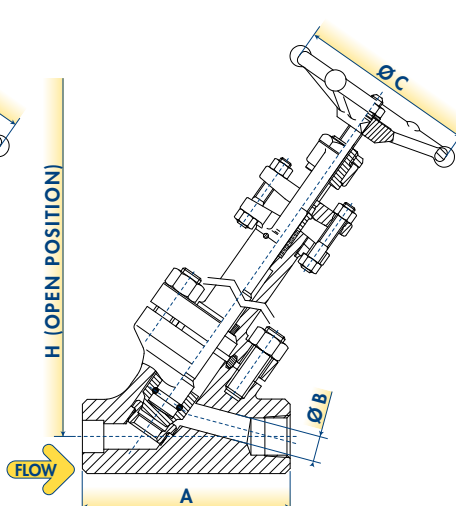

**OTHER END CONNECTION
TYPES AVAILABLE**

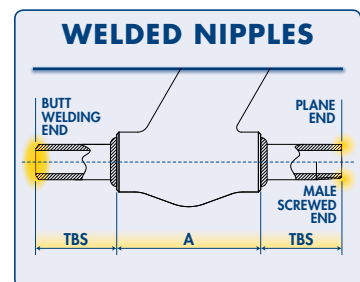
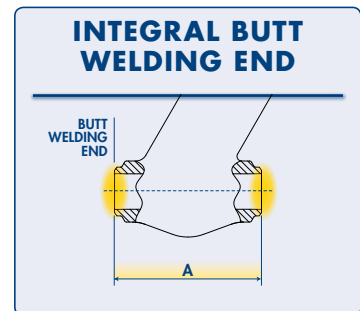

"Y"-PATTERN GLOBE VALVES

BOLTED BONNET GLOBE VALVES CRYOGENIC CONFIGURATION ASME INTEGRAL FLANGED ENDS



WORKING PRESSURE RATING	SIZE		STANDARD DESIGN TYPE	A-RF		A-RJ		B		C		H		WEIGHT		FIGURE
	NPS	DN		mm	in	mm	in	mm	in	mm	in	mm	in	kg	lb	
ASME 150 (SEE NOTE 1)	1/2"	15	S1	152.5 ⁽¹⁾	6.00	N.A.	N.A.	13	0.51	88	3.5	495	19.5	5.0	11.1	1CYH-303
	3/4"	20	S1	178 ⁽¹⁾	7.01	N.A.	N.A.	17.5	0.69	97	3.8	532	21.0	7.4	16.2	1CYH-304
	1"	25	S1	203 ⁽¹⁾	7.99	216 ⁽¹⁾	8.49	22.5	0.89	138	5.4	574	22.6	10.0	22.0	1CYH-305
	1-1/2"	40	S1	229 ⁽¹⁾	9.02	241 ⁽¹⁾	9.52	35	1.38	172	6.8	626	24.6	18.9	41.7	1CYH-307
	2"	50	S1	267 ⁽¹⁾	10.51	282.5 ⁽¹⁾	11.13	45	1.77	172	6.8	648	25.5	28.4	62.5	1CYH-308
ASME 300	1/2"	15	S1	152.5	6.00	163.5	6.44	13	0.51	88	3.5	495	19.5	6.5	14.4	3CYH-303
	3/4"	20	S1	178	7.01	190.5	7.51	17.5	0.69	97	3.8	532	21.0	8.3	18.3	3CYH-304
	1"	25	S1	203	7.99	216	8.49	22.5	0.89	138	5.4	574	22.6	12.6	27.8	3CYH-305
	1-1/2"	40	S1	229	9.02	241	9.52	35	1.38	172	6.8	626	24.6	22.1	48.6	3CYH-307
	2"	50	S1	267	10.51	282.5	11.13	45	1.77	172	6.8	648	25.5	32.6	71.8	3CYH-308
ASME 600	1/2"	15	S1	165	6.50	163.5	6.44	13	0.51	88	3.5	495	19.5	6.8	15.0	6CYH-303
	3/4"	20	S1	191	7.52	190.5	7.52	17.5	0.69	97	3.8	532	21.0	9.1	20.1	6CYH-304
	1"	25	S1	216	8.50	216	8.50	22.5	0.89	138	5.4	574	22.6	13.2	29.2	6CYH-305
	1-1/2"	40	S1	241	9.49	241	9.49	35	1.38	172	6.8	626	24.6	23.1	50.9	6CYH-307
	2"	50	S1	292	11.50	295	11.62	45	1.77	172	6.8	686	27.0	35.7	78.7	6CYH-308
ASME 1500	1/2"	15	S1	216	8.50	216	8.50	12	0.47	97	3.8	543	21.4	12.6	27.8	15CYHF-303
	3/4"	20	S1	229	9.02	229	9.02	14.5	0.57	138	5.4	587	23.1	15.2	33.6	15CYHF-304
	1"	25	S1	254	10.00	254	10.00	19	0.75	172	6.8	604	23.8	20.0	44.0	15CYHF-305
	1-1/2"	40	S1	305	12.01	305	12.01	31	1.22	172	6.8	686	27.0	32.6	71.8	15CYHF-307
	2"	50	S1	368	14.49	371.5	14.61	38	1.50	234	9.2	791	31.1	63.0	138.9	15CYHF-308
ASME 2500	1/2"	15	S2	264	10.39	264	10.39	11	0.43	138	5.4	620	24.4	18.9	41.7	25CYRF-303
	3/4"	20	S2	273	10.75	273	10.75	14.5	0.57	138	5.4	626	24.6	22.4	49.3	25CYRF-304
	1"	25	S2	308	12.13	308	12.13	19	0.75	172	6.8	664	26.2	34.7	76.4	25CYRF-305
	1-1/2"	40	S2	384	15.12	387	15.24	28	1.10	234	9.2	774	30.5	67.7	149.3	25CYRF-307
	2"	50	S2	451	17.76	454	17.88	38	1.50	320	12.6	785	30.9	74.6	164.4	25CYRF-308

FULL BORE

BFE reserves the right to change designs, dimensions or specifications without notice.

PRODUCT FEATURES:

- Outside Screw and Yoke (OS&Y).
 - Self aligning two piece packing gland.
 - Integral backseat.
 - Integral body flanges.
 - Bonnet Extension.
- NOTE 1: Face-to-Face acc.to ASME B16.10 related to class 300.

DESIGN TYPE S1
SPIRAL WOUND GASKET
BODY-BONNET CONNECTION

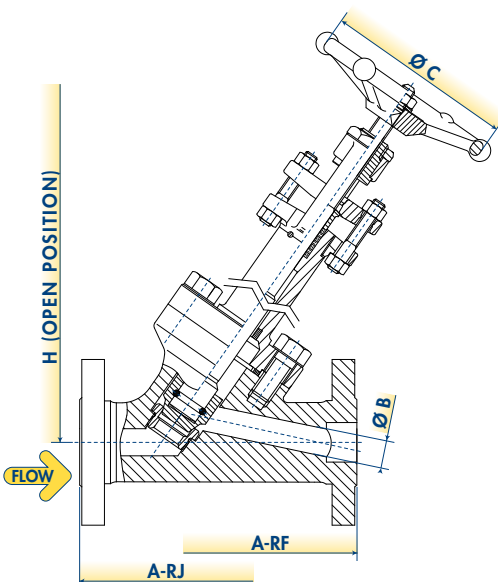

DESIGN TYPE S2
RING JOINT
BODY-BONNET CONNECTION

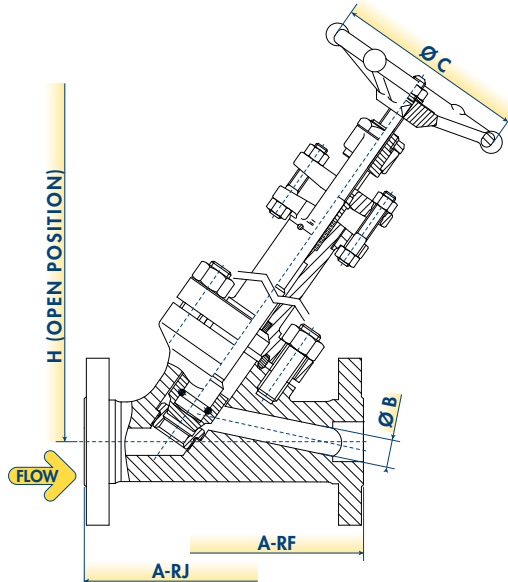

"Y"-PATTERN GLOBE VALVES

BOLTED BONNET GLOBE VALVES BELLOW SEAL CONFIGURATION THREADED AND SOCKET WELD ENDS



WORKING PRESSURE RATING	SIZE		STANDARD DESIGN TYPE	A		B		C		H		WEIGHT		FIGURE
	NPS	DN		mm	in	mm	in	mm	in	mm	in	kg	lb	
ASME 800	1/4"	6	P4	85	3.35	7	0.28	88	3.5	209	8.2	2.6	5.8	SYH 301
	3/8"	10	P4	85	3.35	9	0.35	88	3.5	209	8.2	2.6	5.8	SYH 302
	1/2"	15	P4	152.5	6.00	13	0.51	88	3.5	215	8.4	3.7	8.1	SYH 303
	3/4"	20	P4	115	4.53	17	0.67	97	3.8	248	9.7	5.5	12.0	SYH 304
	1"	25	P4	135	5.31	22	0.87	138	5.4	298	11.7	9.1	20.1	SYH 305
	1-1/4"	32	P4	165	6.50	29	1.14	138	5.4	347	13.6	10.5	23.1	SYH 306
	1-1/2"	40	P4	229	9.02	35	1.38	172	6.8	392	15.4	19.4	42.8	SYH 307
2"	50	P4	190	7.50	45	1.77	172	6.8	472	18.6	32.0	70.6	SYH 308	
ASME 1500	1/4"	6	P4	85	3.54	7	0.28	88	3.5	253	10.0	3.7	5.7	9SYH 301
	3/8"	10	P4	85	3.54	9	0.35	88	3.5	253	10.0	3.7	5.7	9SYH 302
	1/2"	15	P4	115	4.53	12	0.47	138	5.4	267	10.5	4.7	10.4	9SYH 303
	3/4"	20	P4	135	5.31	15	0.59	172	6.8	315	12.4	7.4	16.2	9SYH 304
	1"	25	P4	220	8.66	20	0.79	234	9.2	342	13.5	9.5	20.8	9SYH 305
	1-1/4"	32	P4	165	7.09	27	1.06	234	6.8	440	17.3	14.2	27.6	9SYH 306
	1-1/2"	40	P4	245	9.65	32	1.26	320	12.6	490	19.3	24.2	53.2	9SYH 307
2"	50	P4	230	9.06	40	1.57	320	12.6	561	22.1	39.9	88.0	9SYH 308	
ASME 2500	1/4"	6	P5	85	3.35	7	0.28	138	5.4	275	10.8	4.2	9.3	25SYR 301
	3/8"	10	P5	85	3.35	9	0.35	138	5.4	341	13.4	7.4	16.2	25SYR 302
	1/2"	15	P5	115	4.53	11	0.43	172	6.8	407	16.0	12.6	27.8	25SYR 303
	3/4"	20	P5	145	5.71	15	0.59	234	9.2	440	17.3	12.6	27.8	25SYR 304
	1"	25	P5	210	8.27	19	0.75	320	12.6	484	19.1	28.4	62.5	25SYR 305
	1-1/4"	32	P5	165	6.50	26	1.02	320	12.6	517	20.4	36.8	81.0	25SYR 306
	1-1/2"	40	P5	230	9.06	29	1.14	320	12.6	539	21.2	44.1	97.2	25SYR 307
	2"	50	P6	220	8.66	38	1.50	400	15.7	616	24.3	46.2	101.9	25SYR 308

FULL BORE

BFE reserves the right to change designs, dimensions or specifications without notice.

PRODUCT FEATURES:

- Outside Screw and Yoke (OS&Y).
- Self aligning two piece packing gland.
- Integral backseat.

DESIGN TYPE P4

**HANDWHEEL OPERATED
& SPIRAL WOUND
GASKET BODY-BONNET
CONNECTION**

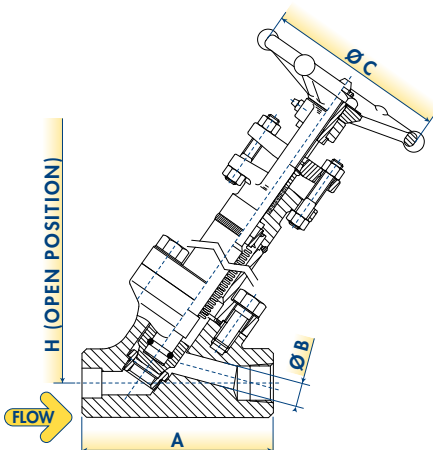

DESIGN TYPE P5

**HANDWHEEL OPERATED
WITH THRUST BEARINGS
& RING JOINT GASKET
BODY-BONNET CONNECTION**

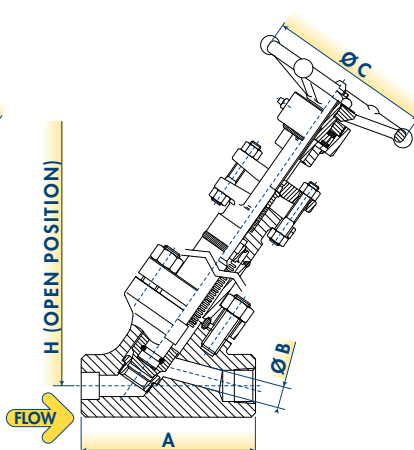

DESIGN TYPE P6

**GEAR OPERATED
& RING JOINT GASKET
BODY-BONNET CONNECTION**

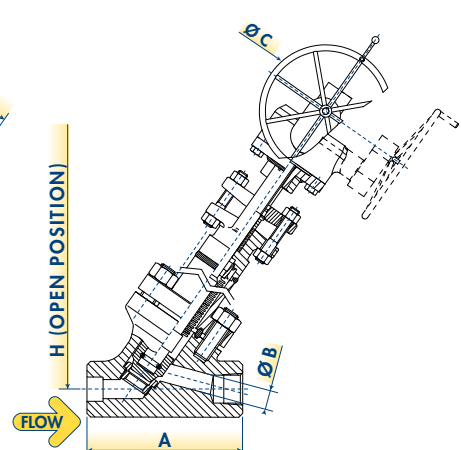

INTEGRAL BUTT WELDING END

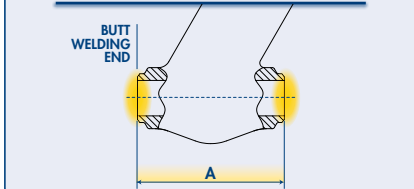

**OTHER END
CONNECTION
TYPES AVAILABLE**

WELDED NIPPLES

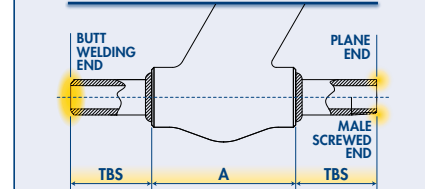

"Y"-PATTERN GLOBE VALVES

BOLTED BONNET GLOBE VALVES BELLOW SEAL CONFIGURATION ASME INTEGRAL FLANGED ENDS



WORKING PRESSURE RATING	SIZE		STANDARD DESIGN TYPE	A-RF		A-RJ		B		C		H		WEIGHT		FIGURE
	NPS	DN		mm	in	mm	in	mm	in	mm	in	mm	in	kg	lb	
ASME 150 (SEE NOTE 1)	1/2"	15	P4	152.5 ⁽¹⁾	6.00	N.A.	N.A.	13	0.51	88	3.5	259	10.2	5.0	11.0	1SYH 303
	3/4"	20	P4	178 ⁽¹⁾	7.01	N.A.	N.A.	17.5	0.69	97	3.8	304	12.0	8.4	18.5	1SYH 304
	1"	25	P4	203 ⁽¹⁾	7.99	216 ⁽¹⁾	8.49	22.5	0.89	138	5.4	354	13.9	11.4	25.2	1SYH 305
	1-1/2"	40	P4	229 ⁽¹⁾	9.02	241 ⁽¹⁾	9.52	35	1.38	138	5.4	416	16.4	21.7	47.7	1SYH 307
	2"	50	P4	267 ⁽¹⁾	10.51	282.5 ⁽¹⁾	11.13	45	1.77	172	6.8	442	17.4	32.8	72.3	1SYH 308
ASME 300	1/2"	15	P4	152.5	6.00	163.5	6.44	13	0.51	88	3.5	259	10.2	5.4	11.9	3SYH 303
	3/4"	20	P4	178	7.01	190.5	7.51	17.5	0.69	97	3.8	304	12.0	9.2	20.3	3SYH 304
	1"	25	P4	203	7.99	216	8.49	22.5	0.89	138	5.4	354	13.9	12.7	28.1	3SYH 305
	1-1/2"	40	P4	229	9.02	241	9.52	35	1.38	138	5.4	416	16.4	24.3	53.5	3SYH 307
	2"	50	P4	267	10.51	282.5	11.13	45	1.77	172	6.8	442	17.4	36.8	81.0	3SYH 308
ASME 600	1/2"	15	P4	165	6.50	163.5	6.44	13	0.51	88	3.5	259	10.2	7.7	17.1	6SYH 303
	3/4"	20	P4	191	7.52	190.5	7.52	17.5	0.69	97	3.8	304	12.0	10.5	23.1	6SYH 304
	1"	25	P4	216	8.50	216	8.50	22.5	0.89	138	5.4	354	13.9	13.8	30.4	6SYH 305
	1-1/2"	40	P4	241	9.49	241	9.49	35	1.38	138	5.4	416	16.4	25.6	56.4	6SYH 307
	2"	50	P4	292	11.50	295	11.62	45	1.77	172	6.8	488	19.2	37.4	82.5	6SYH 308
ASME 1500	1/2"	15	P4	216	8.50	216	8.50	12	0.47	138	5.4	317	12.5	11.2	24.6	15SYHF 303
	3/4"	20	P4	229	9.02	229	9.02	14.5	0.57	138	5.4	370	14.6	16.9	37.3	15SYHF 304
	1"	25	P4	254	10.00	254	10.00	19	0.75	138	5.4	389	15.3	22.3	49.2	15SYHF 305
	1-1/2"	40	P4	305	12.01	305	12.01	31	1.22	172	6.8	488	19.2	39.4	86.8	15SYHF 307
	2"	50	P4	368	14.49	371.5	14.61	38	1.50	234	9.2	614	24.2	76.1	167.8	15SYHF 308
ASME 2500	1/2"	15	P5	264	10.39	264	10.39	11	0.43	138	5.4	409	16.1	21.7	47.7	25SYRF 303
	3/4"	20	P5	273	10.75	273	10.75	14.5	0.57	138	5.4	416	16.4	24.3	53.5	25SYRF 304
	1"	25	P5	308	12.13	308	12.13	19	0.75	172	6.8	462	18.2	39.4	86.8	25SYRF 305
	1-1/2"	40	P5	384	15.12	387	15.24	28	1.10	234	9.2	594	23.4	80.7	178.0	25SYRF 307
	2"	50	P6	451	17.76	454	17.88	38	1.50	400	15.7	607	23.9	87.9	193.9	25SYRF 308

FULL BORE

BFE reserves the right to change designs, dimensions or specifications without notice.

PRODUCT FEATURES:

- Outside Screw and Yoke (OS&Y).
 - Self aligning two piece packing gland.
 - Integral backseat.
 - Integral body flanges.
- NOTE 1: Face-to-Face acc.to ASME B16.10 related to class 300.

DESIGN TYPE P4

**HANDWHEEL OPERATED
& SPIRAL WOUND
GASKET BODY-BONNET
CONNECTION**

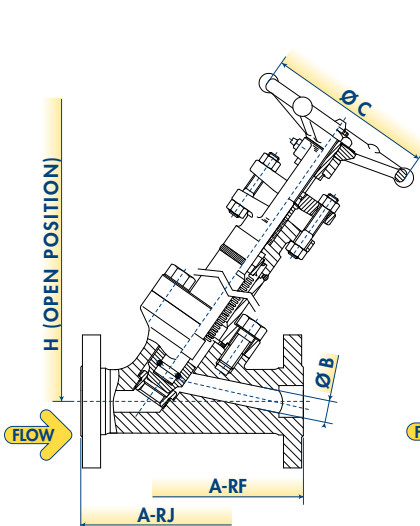

DESIGN TYPE P5

**HANDWHEEL OPERATED
WITH THRUST BEARINGS &
RING JOINT GASKET
BODY-BONNET CONNECTION**

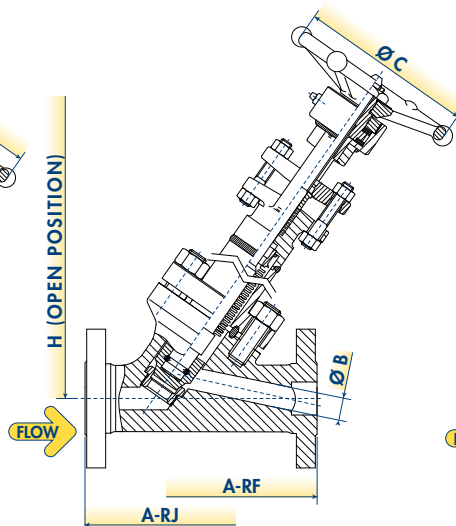

DESIGN TYPE P6

**GEAR OPERATED & RING
JOINT GASKET
BODY-BONNET
CONNECTION**

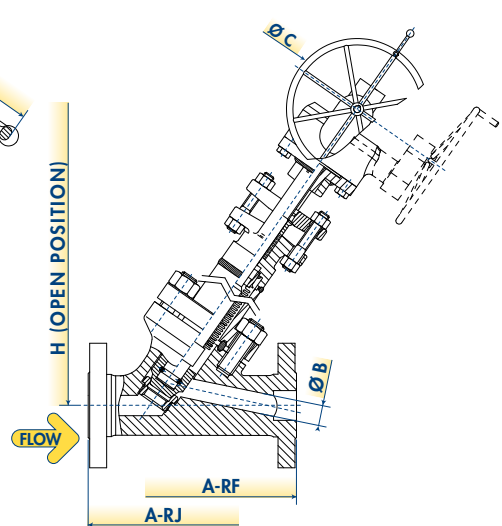

"Y"-PATTERN GLOBE VALVES

WELDED BONNET GLOBE VALVES BASIC CONFIGURATION THREADED AND SOCKET WELD ENDS



WORKING PRESSURE RATING	SIZE		STANDARD DESIGN TYPE	A		B		C		H		WEIGHT		FIGURE
	NPS	DN		mm	in	mm	in	mm	in	mm	in	kg	lb	
ASME 800	1/4"	6	W1	85	3.35	7	0.28	88	3.5	174	6.9	2	4.4	Y 301
	3/8"	10	W1	85	3.35	9	0.35	88	3.5	174	6.9	2	4.4	Y 302
	1/2"	15	W1	85	3.35	13	0.51	88	3.5	174	6.9	2	4.4	Y 303
	3/4"	20	W1	105	4.13	17	0.67	97	3.8	215	8.5	3.3	7.3	Y 304
	1"	25	W1	120	4.72	22	0.87	138	5.4	255	10.0	5	11.0	Y 305
	1-1/4"	32	W1	165	6.50	29	1.14	172	6.8	255	10.0	11	24.3	Y 306
	1-1/2"	40	W1	165	6.50	35	1.38	172	6.8	318	12.5	11	24.3	Y 307
2"	50	W1	190	7.48	45	1.77	172	6.8	375	14.8	15	33.1	Y 308	
ASME 1500	1/4"	6	W1	85	3.35	7	0.28	88	3.5	175	6.9	2	4.4	9Y 301
	3/8"	10	W1	85	3.35	9	0.35	88	3.5	175	6.9	2	4.4	9Y 302
	1/2"	15	W1	85	3.35	10	0.39	97	3.8	215	8.5	3.5	7.7	9Y 303
	3/4"	20	W1	105	4.13	15	0.59	138	5.4	255	10.0	5.3	11.7	9Y 304
	1"	25	W1	120	4.72	22	0.87	138	5.4	280	11.0	11	24.3	9Y 305
	1-1/4"	32	W1	165	6.50	27	1.06	172	6.8	315	12.4	11	24.3	9Y 306
	1-1/2"	40	W1	165	6.50	32	1.26	172	6.8	380	15.0	16.5	36.4	9Y 307
2"	50	W1	190	7.48	43	1.69	234	9.2	450	17.7	26	57.3	9Y 308	
ASME 2500	1/4"	6	W2	85	3.35	7	0.28	88	3.5	220	8.7	3.5	7.7	25Y 301
	3/8"	10	W2	85	3.35	9	0.35	88	3.5	220	8.7	3.5	7.7	25Y 302
	1/2"	15	W2	105	4.13	11	0.43	138	5.4	240	9.4	5	11.0	25Y 303
	3/4"	20	W2	120	4.72	14.5	0.57	138	5.4	275	10.8	11.5	25.4	25Y 304
	1"	25	W2	165	6.50	19	0.75	138	5.4	310	12.2	12.5	27.6	25Y 305
	1-1/4"	32	W2	165	6.50	26	1.02	172	6.8	310	12.2	12.5	27.6	25Y 306
	1-1/2"	40	W2	190	7.48	29	1.14	172	6.8	360	14.2	17	37.5	25Y 307
2"	50	W2	220	8.66	38	1.50	234	9.2	440	17.3	26	57.3	25Y 308	
ASME 4500	1/4"	6	W2	120	4.72	7	0.28	138	5.4	240	9.4	5.5	12.1	45Y 301
	3/8"	10	W2	120	4.72	7	0.28	138	5.4	240	9.4	5.5	12.1	45Y 302
	1/2"	15	W2	120	4.72	8	0.31	138	5.4	245	9.6	5.6	12.3	45Y 303
	3/4"	20	W2	165	6.50	11	0.43	172	6.8	305	12.0	14	30.9	45Y 304
	1"	25	W2	165	6.50	14	0.55	172	6.8	310	12.2	14	30.9	45Y 305
	1-1/2"	40	W2	220	8.66	25	0.98	234	9.2	420	16.5	28	61.7	45Y 307
	2"	50	W4	224	8.82	32	1.26	400	15.7	450	17.7	32	70.5	45Y 308

FULL BORE

BFE reserves the right to change designs, dimensions or specifications without notice.

PRODUCT FEATURES:

- Outside Screw and Yoke (OS&Y).
- Self aligning two piece packing gland.
- Integral backseat.
- Body-Bonnet weld to ASME IX.

**DESIGN TYPE W1
HANDWHEEL OPERATED AND
V-GROOVE SEAL WELD
BODY-BONNET CONNECTION**

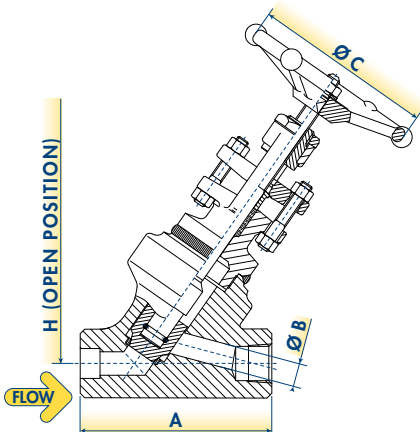

**DESIGN TYPE W2
HANDWHEEL OPERATED AND
TEE JOINT FILLED WELD
BODY-BONNET CONNECTION**

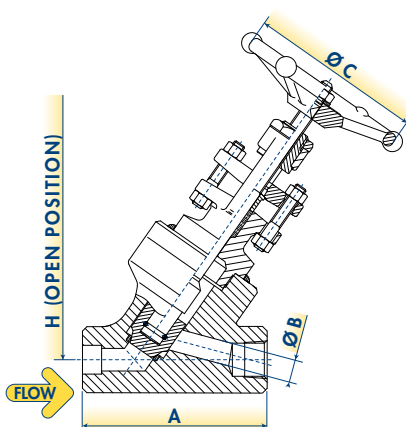

**DESIGN TYPE W4
GEAR OPERATED AND
TEE JOINT FILLED WELD
BODY-BONNET CONNECTION**

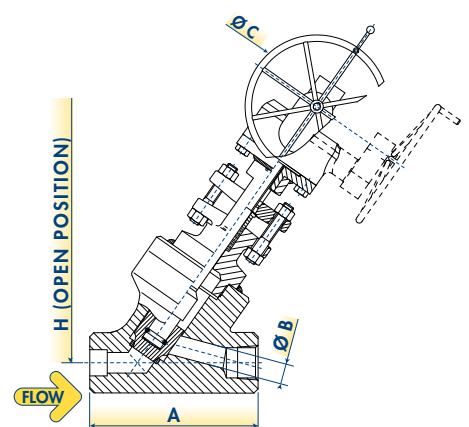

INTEGRAL BUTT WELDING END

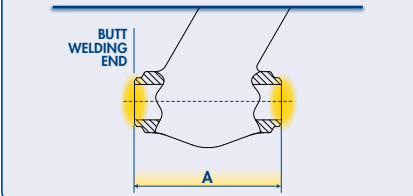

**OTHER END
CONNECTION
TYPES AVAILABLE**

WELDED NIPPLES

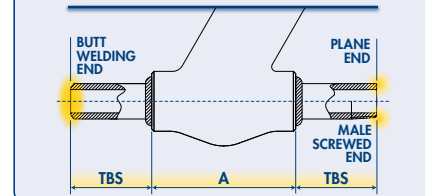

"Y"-PATTERN GLOBE VALVES

WELDED BONNET GLOBE VALVES BASIC CONFIGURATION ASME INTEGRAL FLANGED ENDS



WORKING PRESSURE RATING	SIZE		STANDARD DESIGN TYPE	A-RF		A-RJ		B		C		H		WEIGHT		FIGURE
	NPS	DN		mm	in	mm	in	mm	in	mm	in	mm	in	kg	lb	
ASME 150 (SEE NOTE 1)	1/2"	15	W3	152.5 ⁽¹⁾	6.00	N.A.	N.A.	13	0.51	88	3.5	216	8.5	3.3	7.3	1YHW 303
	3/4"	20	W3	178 ⁽¹⁾	7.01	N.A.	N.A.	17.5	0.69	97	3.8	253	10.0	5.6	12.3	1YHW 304
	1"	25	W3	203 ⁽¹⁾	7.99	216 ⁽¹⁾	8.49	22.5	0.89	138	5.4	295	11.6	7.6	16.8	1YHW 305
	1-1/2"	40	W3	229 ⁽¹⁾	9.02	241 ⁽¹⁾	9.52	35	1.38	172	6.8	347	13.6	14.4	31.8	1YHW 307
	2"	50	W3	267 ⁽¹⁾	10.51	282.5 ⁽¹⁾	11.13	45	1.77	172	6.8	369	14.5	21.9	48.2	1YHW 308
ASME 300	1/2"	15	W3	152.5	6.00	163.5	6.44	13	0.51	88	3.5	216	8.5	3.6	7.9	3YHW 303
	3/4"	20	W3	178	7.01	190.5	7.51	17.5	0.69	97	3.8	253	10.0	6.1	13.5	3YHW 304
	1"	25	W3	203	7.99	216	8.49	22.5	0.89	138	5.4	295	11.6	8.5	18.7	3YHW 305
	1-1/2"	40	W3	229	9.02	241	9.52	35	1.38	172	6.8	347	13.6	16.2	35.7	3YHW 307
	2"	50	W3	267	10.51	282.5	11.13	45	1.77	172	6.8	369	14.5	24.5	54.0	3YHW 308
ASME 600	1/2"	15	W3	165	6.50	163.5	6.44	13	0.51	88	3.5	216	8.5	5.2	11.4	6YHW 303
	3/4"	20	W3	191	7.52	190.5	7.52	17.5	0.69	97	3.8	253	10.0	7.0	15.4	6YHW 304
	1"	25	W3	216	8.50	216	8.50	22.5	0.89	138	5.4	295	11.6	9.2	20.3	6YHW 305
	1-1/2"	40	W3	241	9.49	241	9.49	35	1.38	172	6.8	347	13.6	17.1	37.6	6YHW 307
	2"	50	W3	292	11.50	295	11.62	45	1.77	172	6.8	407	16.0	24.9	55.0	6YHW 308
ASME 1500	1/2"	15	W3	216	8.50	216	8.50	12	0.47	97	3.8	264	10.4	7.4	16.4	15YHWF 303
	3/4"	20	W3	229	9.02	229	9.02	14.5	0.57	138	5.4	308	12.1	11.3	24.9	15YHWF 304
	1"	25	W3	254	10.00	254	10.00	19	0.75	172	6.8	325	12.8	14.9	32.8	15YHWF 305
	1-1/2"	40	W3	305	12.01	305	12.01	31	1.22	172	6.8	407	16.0	26.3	57.9	15YHWF 307
	2"	50	W3	368	14.49	371.5	14.61	38	1.50	234	9.2	512	20.1	50.8	111.9	15YHWF 308
ASME 2500	1/2"	15	W3	264	10.39	264	10.39	11	0.43	138	5.4	341	13.4	14.4	31.8	25YHWF 303
	3/4"	20	W3	273	10.75	273	10.75	14.5	0.57	138	5.4	347	13.6	16.2	35.7	25YHWF 304
	1"	25	W3	308	12.13	308	12.13	19	0.75	172	6.8	385	15.2	26.3	57.9	25YHWF 305
	1-1/2"	40	W3	384	15.12	387	15.24	28	1.10	234	9.2	495	19.5	53.8	118.6	25YHWF 307
	2"	50	W3	451	17.76	454	17.88	38	1.50	320	12.6	506	19.9	58.6	129.2	25YHWF 308

FULL BORE

BFE reserves the right to change designs, dimensions or specifications without notice.

PRODUCT FEATURES:

- Outside Screw and Yoke (OS&Y).
 - Self aligning two piece packing gland.
 - Integral backseat.
 - Integral body flanges
 - Body-Bonnet weld to ASME IX.
- NOTE 1: Face-to-Face acc.to ASME B16.10 related to class 300.

DESIGN TYPE W3 FULL PENETRATION WELD BODY-BONNET CONNECTION

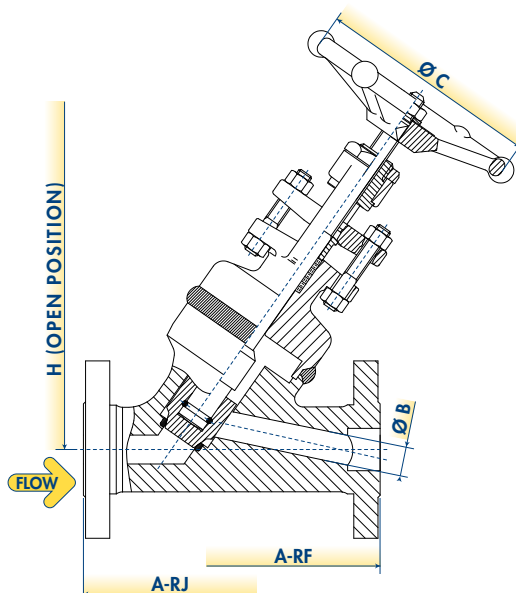

"Y"-PATTERN GLOBE VALVES

WELDED BONNET GLOBE VALVES CRYOGENIC CONFIGURATION THREADED AND SOCKET WELD ENDS



WORKING PRESSURE RATING	SIZE		STANDARD DESIGN TYPE	A		B		C		H		WEIGHT		FIGURE
	NPS	DN		mm	in	mm	in	mm	in	mm	in	kg	lb	
ASME 800	1/4"	6	W1	85	3.35	7	0.28	88	3.5	471	18.5	3.4	7.4	CY 301
	3/8"	10	W1	85	3.35	9	0.35	88	3.5	471	18.5	3.4	7.4	CY 302
	1/2"	15	W1	85	3.35	13	0.51	88	3.5	471	18.5	3.4	7.4	CY 303
	3/4"	20	W1	105	4.13	17	0.67	97	3.8	516	20.3	5.5	12.2	CY 304
	1"	25	W1	120	4.72	22	0.87	138	5.4	560	22.0	8.4	18.5	CY 305
	1-1/4"	32	W1	165	6.50	29	1.14	172	6.8	560	22.0	18.5	40.7	CY 306
	1-1/2"	40	W1	165	6.50	35	1.38	172	6.8	629	24.8	18.5	40.7	CY 307
2"	50	W1	190	7.48	45	1.77	172	6.8	692	27.2	25.2	55.6	CY 308	
ASME 1500	1/4"	6	W1	85	3.35	7	0.28	88	3.5	472	18.6	3.4	7.4	9CY 301
	3/8"	10	W1	85	3.35	9	0.35	88	3.5	472	18.6	3.4	7.4	9CY 302
	1/2"	15	W1	85	3.35	10	0.39	97	3.8	516	20.3	5.9	13.0	9CY 303
	3/4"	20	W1	105	4.13	15	0.59	138	5.4	560	22.0	8.9	19.6	9CY 304
	1"	25	W1	120	4.72	22	0.87	138	5.4	587	23.1	18.5	40.7	9CY 305
	1-1/4"	32	W1	165	6.50	27	1.06	172	6.8	626	24.6	18.5	40.7	9CY 306
	1-1/2"	40	W1	165	6.50	32	1.26	172	6.8	697	27.5	27.7	61.1	9CY 307
2"	50	W1	190	7.48	43	1.69	234	9.2	774	30.5	43.7	96.3	9CY 308	
ASME 2500	1/4"	6	W2	85	3.35	7	0.28	88	3.5	521	20.5	5.9	13.0	25CY 301
	3/8"	10	W2	85	3.35	9	0.35	88	3.5	521	20.5	5.9	13.0	25CY 302
	1/2"	15	W2	105	4.13	11	0.43	138	5.4	543	21.4	8.4	18.5	25CY 303
	3/4"	20	W2	120	4.72	14.5	0.57	138	5.4	582	22.9	19.3	42.6	25CY 304
	1"	25	W2	165	6.50	19	0.75	138	5.4	620	24.4	21.0	46.3	25CY 305
	1-1/4"	32	W2	165	6.50	26	1.02	172	6.8	620	24.4	21.0	46.3	25CY 306
	1-1/2"	40	W2	190	7.48	29	1.14	172	6.8	675	26.6	28.6	63.0	25CY 307
2"	50	W2	220	8.66	38	1.50	234	9.2	763	30.1	43.7	96.3	25CY 308	
ASME 4500	1/4"	6	W2	120	4.72	7	0.28	138	5.4	543	21.4	9.2	20.4	45CY 301
	3/8"	10	W2	120	4.72	7	0.28	138	5.4	543	21.4	9.2	20.4	45CY 302
	1/2"	15	W2	120	4.72	8	0.31	138	5.4	549	21.6	9.4	20.7	45CY 303
	3/4"	20	W2	165	6.50	11	0.43	172	6.8	615	24.2	23.5	51.9	45CY 304
	1"	25	W2	165	6.50	14	0.55	172	6.8	620	24.4	23.5	51.9	45CY 305
	1-1/2"	40	W2	220	8.66	25	0.98	234	9.2	741	29.2	47.0	103.7	45CY 307
	2"	50	W4	224	8.82	32	1.26	400	15.7	774	30.5	53.8	118.5	45CY 308

FULL BORE

B/E reserves the right to change designs, dimensions or specifications without notice.

PRODUCT FEATURES:

- Outside Screw and Yoke (OS&Y).
- Self aligning two piece packing gland.
- Integral backseat.
- Body-Bonnet weld to ASME IX.

**DESIGN TYPE W1
V-GROOVE SEAL
WELD BODY-BONNET
CONNECTION**

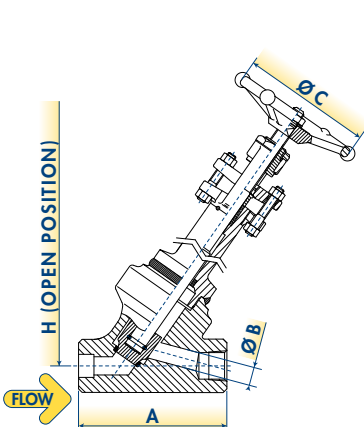

**DESIGN TYPE W2
TEE JOINT FILLET
WELD BODY-BONNET
CONNECTION**

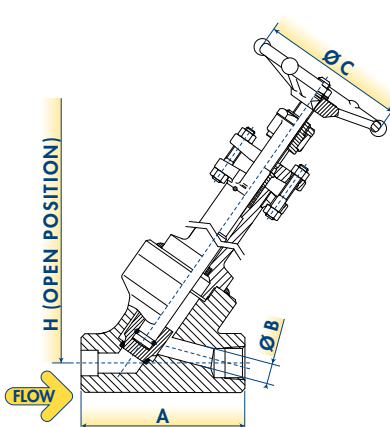

**DESIGN TYPE W4
GEAR OPERATED & TEE
JOINT FILLET WELD
BODY-BONNET CONNECTION**

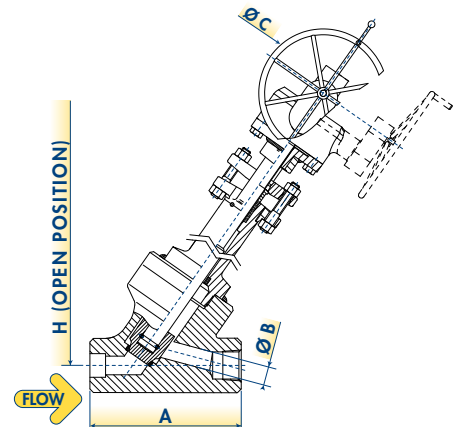

INTEGRAL BUTT WELDING END

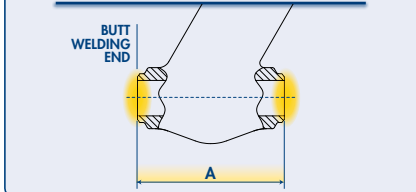

**OTHER END
CONNECTION
TYPES AVAILABLE**

WELDED NIPPLES

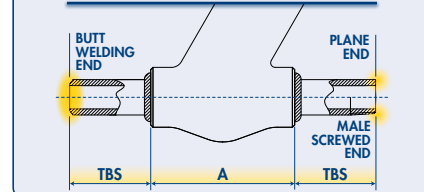

"Y"-PATTERN GLOBE VALVES

WELDED BONNET GLOBE VALVES CRYOGENIC CONFIGURATION ASME INTEGRAL FLANGED ENDS



WORKING PRESSURE RATING	SIZE		STANDARD DESIGN TYPE	A-RF		A-RJ		B		C		H		WEIGHT		FIGURE
	NPS	DN		mm	in	mm	in	mm	in	mm	in	mm	in	kg	lb	
ASME 150 (SEE NOTE 1)	1/2"	15	W3	152.5 ⁽¹⁾	6.00	N.A.	N.A.	13	0.51	88	3.5	495	19.5	5.0	11.0	1CYHW 303
	3/4"	20	W3	178 ⁽¹⁾	7.01	N.A.	N.A.	17.5	0.69	97	3.8	532	21.0	8.4	18.5	1CYHW 304
	1"	25	W3	203 ⁽¹⁾	7.99	216 ⁽¹⁾	5.50	22.5	0.89	138	5.4	574	22.6	11.4	25.2	1CYHW 305
	1-1/2"	40	W3	229 ⁽¹⁾	9.02	241 ⁽¹⁾	7.00	35	1.38	172	6.8	626	24.6	21.7	47.7	1CYHW 307
	2"	50	W3	267 ⁽¹⁾	10.51	282.5 ⁽¹⁾	8.49	45	1.77	172	6.8	648	25.5	32.8	72.3	1CYHW 308
ASME 300	1/2"	15	W3	152.5	6.00	163.5	6.44	13	0.51	88	3.5	495	19.5	5.4	11.9	3CYHW 303
	3/4"	20	W3	178	7.01	190.5	7.51	17.5	0.69	97	3.8	532	21.0	9.2	20.3	3CYHW 304
	1"	25	W3	203	7.99	216	8.49	22.5	0.89	138	5.4	574	22.6	12.7	28.1	3CYHW 305
	1-1/2"	40	W3	229	9.02	241	9.52	35	1.38	172	6.8	626	24.6	24.3	53.5	3CYHW 307
	2"	50	W3	267	10.51	282.5	11.13	45	1.77	172	6.8	648	25.5	36.8	81.0	3CYHW 308
ASME 600	1/2"	15	W3	165	6.50	163.5	6.44	13	0.51	88	3.5	495	19.5	7.7	17.1	6CYHW 303
	3/4"	20	W3	191	7.52	190.5	7.52	17.5	0.69	97	3.8	532	21.0	10.5	23.1	6CYHW 304
	1"	25	W3	216	8.50	216	8.50	22.5	0.89	138	5.4	574	22.6	13.8	30.4	6CYHW 305
	1-1/2"	40	W3	241	9.49	241	9.49	35	1.38	172	6.8	626	24.6	25.6	56.4	6CYHW 307
	2"	50	W3	292	11.50	295	11.62	45	1.77	172	6.8	686	27.0	37.4	82.5	6CYHW 308
ASME 1500	1/2"	15	W3	216	8.50	216	8.50	12	0.47	97	3.8	543	21.4	11.2	24.6	15CYHWF 303
	3/4"	20	W3	229	9.02	229	9.02	14.5	0.57	138	5.4	587	23.1	16.9	37.3	15CYHWF 304
	1"	25	W3	254	10.00	254	10.00	19	0.75	172	6.8	604	23.8	22.3	49.2	15CYHWF 305
	1-1/2"	40	W3	305	12.01	305	12.01	31	1.22	172	6.8	686	27.0	39.4	86.8	15CYHWF 307
	2"	50	W3	368	14.49	371.5	14.61	38	1.50	234	9.2	791	31.1	76.1	167.8	15CYHWF 308
ASME 2500	1/2"	15	W3	264	10.39	264	10.39	11	0.43	138	5.4	620	24.4	21.7	47.7	25CYHWF 303
	3/4"	20	W3	273	10.75	273	10.75	14.5	0.57	138	5.4	626	24.6	24.3	53.5	25CYHWF 304
	1"	25	W3	308	12.13	308	12.13	19	0.75	172	6.8	664	26.2	39.4	86.8	25CYHWF 305
	1-1/2"	40	W3	384	15.12	387	15.24	28	1.10	234	9.2	774	30.5	80.7	178.0	25CYHWF 307
	2"	50	W3	451	17.76	454	17.88	38	1.50	320	12.6	785	30.9	87.9	193.9	25CYHWF 308

FULL BORE

BFE reserves the right to change designs, dimensions or specifications without notice.

PRODUCT FEATURES:

- Outside Screw and Yoke (OS&Y).
 - Self aligning two piece packing gland.
 - Integral backseat.
 - Integral body flanges.
 - Body-Bonnet weld to ASME IX.
- NOTE 1: Face-to-Face acc.to ASME B16.10 related to class 300.

DESIGN TYPE W3

FULL PENETRATION WELD BODY-BONNET CONNECTION

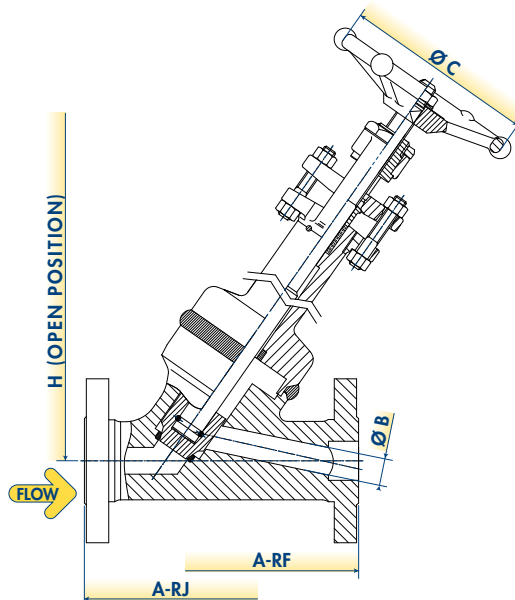

"Y"-PATTERN GLOBE VALVES

WELDED BONNET GLOBE VALVES BELOW SEAL CONFIGURATION THREADED AND SOCKET WELD ENDS



WORKING PRESSURE RATING	SIZE		STANDARD DESIGN TYPE	A		B		C		H		WEIGHT		FIGURE
	NPS	DN		mm	in	mm	in	mm	in	mm	in	kg	lb	
ASME 800	1/4"	6	P1	85	3.35	7	0.28	88	3.5	209	8.2	2.4	5.3	SYHW 301
	3/8"	10	P1	85	3.35	9	0.35	88	3.5	209	8.2	2.4	5.3	SYHW 302
	1/2"	15	P1	85	3.35	13	0.51	88	3.5	215	8.4	3.4	7.4	SYHW 303
	3/4"	20	P1	105	4.13	17	0.67	97	3.8	248	9.7	5.3	11.6	SYHW 304
	1"	25	P1	120	4.72	22	0.87	138	5.4	298	11.7	8.4	18.5	SYHW 305
	1-1/4"	32	P1	165	6.50	29	1.14	138	5.4	347	13.6	9.5	20.8	SYHW 306
	1-1/2"	40	P1	165	6.50	35	1.38	172	6.8	392	15.4	17.9	39.4	SYHW 307
	2"	50	P1	190	7.48	45	1.77	172	6.8	472	18.6	29.4	64.8	SYHW 308
ASME 1500	1/4"	6	P1	85	3.35	7	0.28	97	3.8	209	8.2	3.4	7.4	9SYHW 301
	3/8"	10	P1	85	3.35	9	0.35	97	3.8	209	8.2	3.4	7.4	9SYHW 302
	1/2"	15	P1	85	3.35	10	0.39	138	5.4	267	10.5	4.2	9.3	9SYHW 303
	3/4"	20	P1	105	4.13	15	0.59	172	6.8	315	12.4	6.8	15.0	9SYHW 304
	1"	25	P1	120	4.72	22	0.87	234	9.2	342	13.5	8.7	19.2	9SYHW 305
	1-1/4"	32	P1	165	6.50	27	1.06	234	9.2	385	15.2	12.6	27.8	9SYHW 306
	1-1/2"	40	P1	165	6.50	32	1.26	320	12.6	490	19.3	23.1	50.9	9SYHW 307
	2"	50	P1	190	7.48	43	1.69	320	12.6	561	22.1	38.3	84.5	9SYHW 308
ASME 2500	1/4"	6	P2	85	3.35	7	0.28	97	3.8	297	11.7	5.3	11.6	25SYHW 301
	3/8"	10	P2	85	3.35	9	0.35	138	5.4	330	13.0	6.8	15.0	25SYHW 302
	1/2"	15	P2	105	4.13	11	0.43	172	6.8	385	15.2	7.4	16.2	25SYHW 303
	3/4"	20	P2	120	4.72	14.5	0.57	234	9.2	440	17.3	11.0	24.3	25SYHW 304
	1"	25	P2	165	6.50	19	0.75	320	12.6	517	20.4	17.9	39.4	25SYHW 305
	1-1/4"	32	P2	165	6.50	26	1.02	320	12.6	550	21.7	21.0	46.3	25SYHW 306
	1-1/2"	40	P2	190	7.48	29	1.14	320	12.6	583	23.0	24.2	53.2	25SYHW 307
	2"	50	P3	220	8.66	38	1.50	400	15.7	715	28.1	47.3	104.2	25SYHW 308

FULL BORE

BFE reserves the right to change designs, dimensions or specifications without notice.

PRODUCT FEATURES:

- Outside Screw and Yoke (OS&Y).
- Self aligning two piece packing gland.
- Integral backseat.
- Body-Bonnet weld to ASME IX.

DESIGN TYPE P1 HANDWHEEL OPERATED

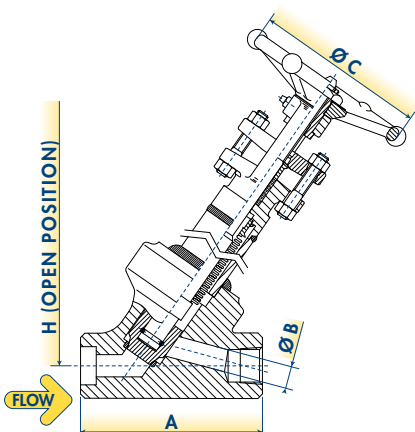

DESIGN TYPE P2 HANDWHEEL OPERATED WITH THRUST BEARINGS

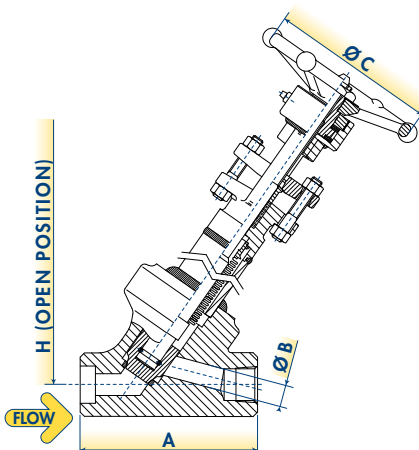

DESIGN TYPE P3 GEAR OPERATED

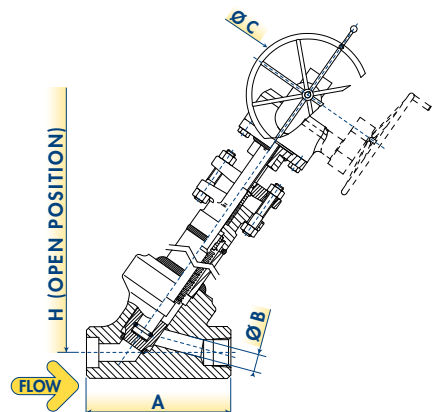

INTEGRAL BUTT WELDING END

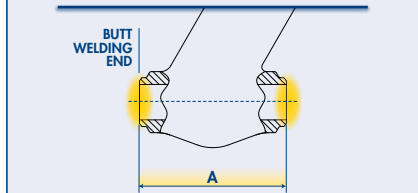

OTHER END
CONNECTION
TYPES AVAILABLE

WELDED NIPPLES

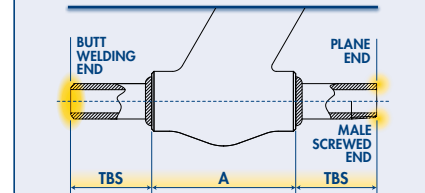

"Y"-PATTERN GLOBE VALVES

WELDED BONNET GLOBE VALVES BELLOW SEAL CONFIGURATION ASME INTEGRAL FLANGED ENDS



WORKING PRESSURE RATING	SIZE		STANDARD DESIGN TYPE	A-RF		A-RJ		B		C		H		WEIGHT		FIGURE
	NPS	DN		mm	in	mm	in	mm	in	mm	in	mm	in	kg	lb	
ASME 150 (SEE NOTE 1)	1/2"	15	P1	152.5 ⁽¹⁾	6.00	N.A.	N.A.	13	0.51	88	3.5	241	9.5	4.1	8.9	1SYHW 303
	3/4"	20	P1	178 ⁽¹⁾	7.01	N.A.	N.A.	17.5	0.69	97	3.8	283	11.2	6.8	15.1	1SYHW 304
	1"	25	P1	203 ⁽¹⁾	7.99	216 ⁽¹⁾	5.50	22.5	0.89	138	5.4	330	13.0	9.3	20.5	1SYHW 305
	1-1/2"	40	P1	229 ⁽¹⁾	9.02	241 ⁽¹⁾	7.00	35	1.38	172	6.8	388	15.3	17.6	38.8	1SYHW 307
	2"	50	P1	267 ⁽¹⁾	10.51	282.5 ⁽¹⁾	8.49	45	1.77	172	6.8	413	16.2	26.7	58.8	1SYHW 308
ASME 300	1/2"	15	P1	152.5	6.00	163.5	6.44	13	0.51	88	3.5	241	9.5	4.4	9.6	3SYHW 303
	3/4"	20	P1	178	7.01	190.5	7.51	17.5	0.69	97	3.8	283	11.2	7.5	16.5	3SYHW 304
	1"	25	P1	203	7.99	216	8.49	22.5	0.89	138	5.4	330	13.0	10.4	22.8	3SYHW 305
	1-1/2"	40	P1	229	9.02	241	9.52	35	1.38	172	6.8	388	15.3	19.7	43.5	3SYHW 307
	2"	50	P1	267	10.51	282.5	11.13	45	1.77	172	6.8	413	16.2	29.9	65.9	3SYHW 308
ASME 600	1/2"	15	P1	165	6.50	163.5	6.44	13	0.51	88	3.5	241	9.5	6.3	13.9	6SYHW 303
	3/4"	20	P1	191	7.52	190.5	7.52	17.5	0.69	97	3.8	283	11.2	8.5	18.8	6SYHW 304
	1"	25	P1	216	8.50	216	8.50	22.5	0.89	138	5.4	330	13.0	11.2	24.7	6SYHW 305
	1-1/2"	40	P1	241	9.49	241	9.49	35	1.38	172	6.8	388	15.3	20.8	45.9	6SYHW 307
	2"	50	P1	292	11.50	295	11.62	45	1.77	172	6.8	456	17.9	30.4	67.1	6SYHW 308
ASME 1500	1/2"	15	P1	216	8.50	216	8.50	12	0.47	97	3.8	296	11.6	9.1	20.0	15SYHWF 303
	3/4"	20	P1	229	9.02	229	9.02	14.5	0.57	138	5.4	345	13.6	13.8	30.4	15SYHWF 304
	1"	25	P1	254	10.00	254	10.00	19	0.75	172	6.8	363	14.3	18.1	40.0	15SYHWF 305
	1-1/2"	40	P1	305	12.01	305	12.01	31	1.22	172	6.8	456	17.9	32.0	70.6	15SYHWF 307
	2"	50	P1	368	14.49	371.5	14.61	38	1.50	234	9.2	573	22.6	61.9	136.5	15SYHWF 308
ASME 2500	1/2"	15	P2	264	10.39	264	10.39	11	0.43	138	5.4	382	15.0	17.6	38.8	25SYHWF 303
	3/4"	20	P2	273	10.75	273	10.75	14.5	0.57	138	5.4	388	15.3	19.7	43.5	25SYHWF 304
	1"	25	P2	308	12.13	308	12.13	19	0.75	172	6.8	431	17.0	32.0	70.6	25SYHWF 305
	1-1/2"	40	P2	384	15.12	387	15.24	28	1.10	234	9.2	554	21.8	65.7	144.7	25SYHWF 307
	2"	50	P3	451	17.76	454	17.88	38	1.50	320	12.6	567	22.3	71.5	157.7	25SYHWF 308

FULL BORE

BFE reserves the right to change designs, dimensions or specifications without notice.

PRODUCT FEATURES:

- Outside Screw and Yoke (OS&Y).
 - Self aligning two piece packing gland.
 - Integral backseat.
 - Integral body flanges.
- NOTE 1: Face-to-Face acc.to ASME B16.10 related to class 300.

DESIGN TYPE P1
HANDWHEEL OPERATED

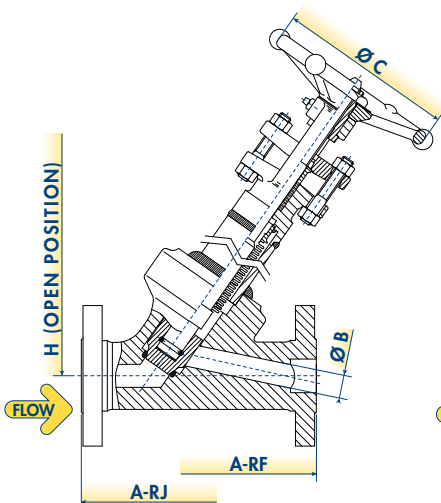

DESIGN TYPE P2
HANDWHEEL OPERATED WITH THRUST BEARINGS

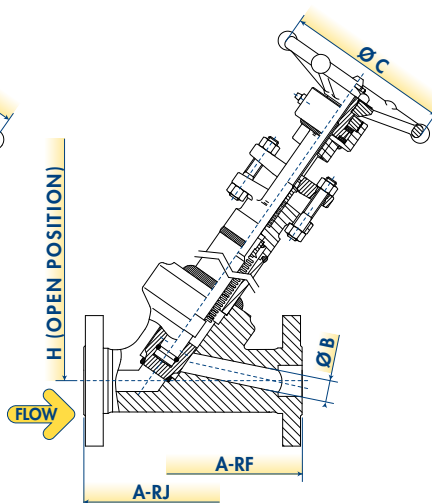

DESIGN TYPE P3
GEAR OPERATED

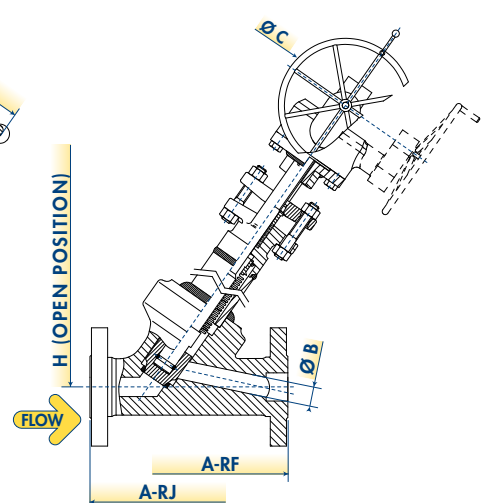

"Y"-PATTERN GLOBE VALVES

AVAILABLE OPTIONS FOR "Y"-PATTERN GLOBE VALVES OTHER VALVE OPTIONS OR CUSTOMISED VERSIONS ARE AVAILABLE ON REQUEST, CONTACT BFE FOR SPECIAL REQUIREMENTS.

STEM EXTENSION

Valve handle can be extended to allow for panel mount and pipe insulation.

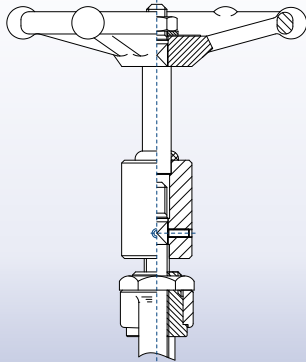

BEVEL GEAR OPERATOR

Gearing can be applied to valves instead the standard handwheel to make operation easier.

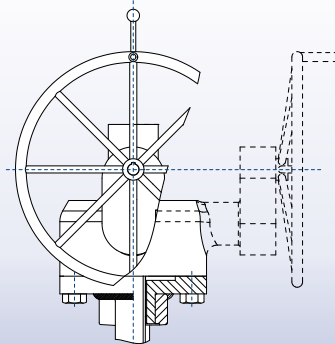

POSITION INDICATOR

Valves can be supplied with standard visual-mechanical indicating device that act as stem cover also.

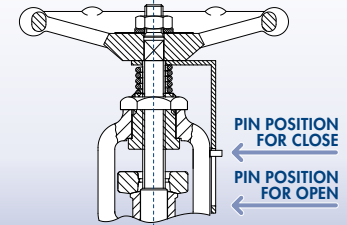

ACTUATOR-READY

Valves can be supplied ready for actuation without the handwheel or gear box. The mounting connection can be BFE Standard or can suit the choice or type of actuator.

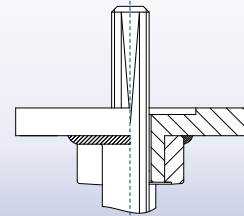

STOP CHECK

Globe valves with stop check option have a guided loose disc allowing the valve to act as a combination globe and check valve. There is the manual control to regulate the opening and closing, and can be completely stopped or shut off. This type of valve will generally be used as a globe valve to start or stop the flow of the media, but will automatically close should pressure be lost in the line, preventing backflow.

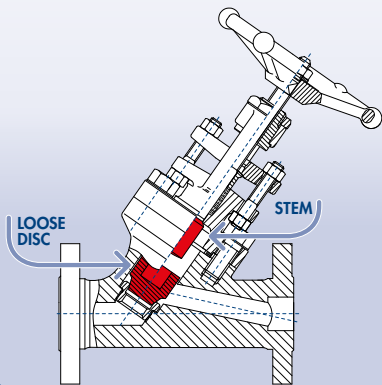

DEAD MAN OPERATOR

Dead Man Handle automatically closes the valve when operator Releases Handle. This means the operator must hold the handle in the open position for the product to flow. The operator can't walk away or the valve will shut off. Locking handle option for our spring return deadman handle is available.

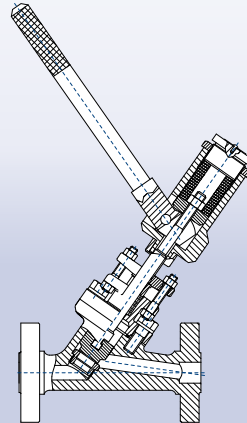

ELECTRIC, PNEUMATIC OR HYDRAULIC ACTUATORS

Motorized controls may be applied to valves of any size for operation in any position or location.

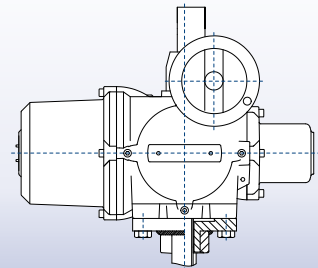

LOCKING DEVICE

Locking devices designed to help prevent accidental or unwanted operation by being built to resist excessive force or unusual abuse. All BFE locking device option are simple but secure. Chain and Padlock available on request.

LOCKING FACILITY

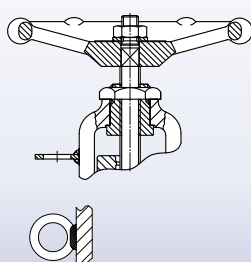

LOCKING FACILITY WITH C&P

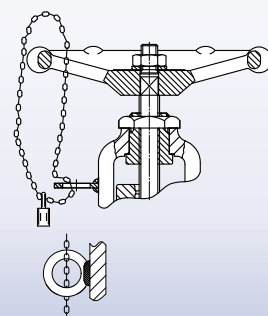

LOCKING DEVICE

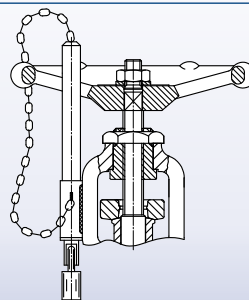

THERMAL EXPANSION STEM COMPENSATOR

Valves which endure large thermal transients have the basic problem that the valve stem and closure member will expand and contract with the danger that a closed valve could become jammed in its seat and in extreme cases this can cause the valve stem to distort. High Temperature Valve configuration is equipped with a spring loaded stem sleeve that will absorb any expansion or contraction caused by temperature fluctuations without affecting the position of the closed valve stem.

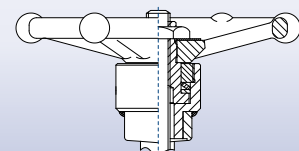

"Y"-PATTERN GLOBE VALVES

AVAILABLE OPTIONS FOR "Y"-PATTERN GLOBE VALVES OTHER VALVE OPTIONS OR CUSTOMISED VERSIONS ARE AVAILABLE ON REQUEST, CONTACT BFE FOR SPECIAL REQUIREMENTS.

■ DISC AND TRIM TYPE

BFE standard plug is the has a quick opening characteristic, this plug provides maximum flow with minimum pressure drop and is ideal when large flows are required just after opening. All BFE standard plugs require a flow direction FTO type. BFE trim variations can offer maximum versatility in flow control application within the capability of globe valve design.

PARABOLIC DISC TRIM TYPE

Characteristic: Linear. This plug covers all Cv ranges and is especially suitable for low differential pressures.

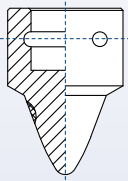

NEEDLE TRIM TYPE

Needle trim design is suitable for use where low valve CV values or low flows are required.

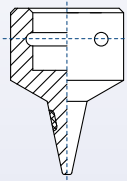

BLOW DOWN TRIM STANDARD TYPE

Blow Down trim design is suitable for use where high differential pressures are present. The high pressure drop causes erosion and cavitation which can destroy conventional globe valves.

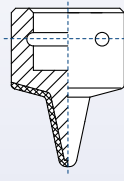

BLOW DOWN TRIM MULTI-STEP TYPE

Improved blow-down trim developed to provide a high number of pressure letdown steps to minimise the potential for excessive noise, cavitation, vibration and erosion. Multi-Step trim has been designed for all fluid combinations, both clean and dirty service. This range of trims is normally customized and designed on the customer design data.

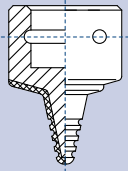

BALL DISC TRIM TYPE

The ball disc is used where the applications involve low pressure and low temperature systems. Though the ball disc can be used for throttling purpose, the efficiency might not be as expected.

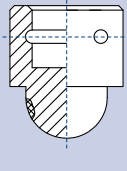

SOFT SEATED PLUG

Soft seated trim provides improved seat tightness at low differential pressures. This design feature includes a plastic sealing member on the valve closure element to supplement the basic metal-to-metal seating function. The design and material selection for these sealing members are based on customer pressure, temperature and compatibility with the line fluid.

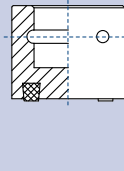

■ STEM DOUBLE SEAL

Stem double seal are fitted to valves when hazardous fluids are handled or when external lubrication is used. Valves operating under vacuum or with high temperature liquid may have a flowing liquid quench between the seals. The most usual form of double seal is two sets of packing, the lantern ring can provide extra stem guidance. BFE can supply the lantern ring version with standard plug or with injector (double ball check type). Other special configuration are available on request.

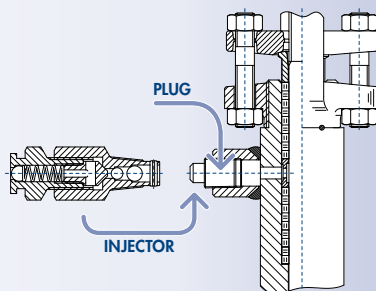

■ BODY-BONNET FULL PENETRATION WELD

BFE standard welded bonnet valves have as standard a seal weld on the body-bonnet connection. Seal weld is a weld that does not contribute anything to the mechanical integrity of an assembly, but is made purely to seal or prevent leakage from, for instance, a threaded joint. When High-End quality is required for body-bonnet weld joint a weld with full penetration can be performed. Full penetration weld is one in which there is a complete penetration and fusion of weld and parent metal throughout the thickness of the joint. A full penetration weld ensures a fully welded interface between the two parts and is generally the strongest joint.

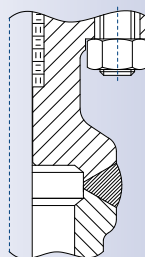

■ SPECIAL END FINISH

The choice of end connections for connecting a valve to its associated pipe is performed by customers. Common end finish steated in the catalogue are socket, threaded, flanged (RF or RJ) and butt-weld ends. BFE is basically able to perform any end finish as per customer request, special end finish Other end finish as follows: hub, compact flange, any ASME B16.5 end finish other than RF and RJ, etc.

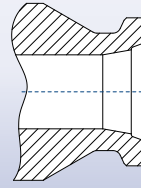

■ LIMIT SWITCH ASSEMBLIES

Position Limit Switch assemblies enables a remote signaling of the control system the opening of the valve. It can be equipped with one or two switches actuated by closing or opening of the valve. Limit swich can be selected by customer, bracket is designed by BFE.

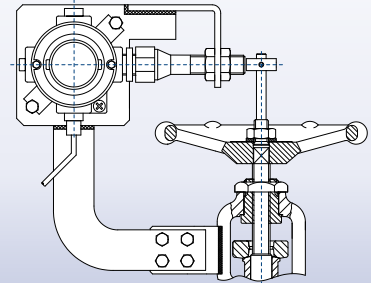

■ LIVE LOADING

Live Loading System consists of a spring system installed on packing stud to warrant a continuous load on valve packing. Spring are specially designed to allow appropriate load in case of packing settling by minimizing initial load and friction. Mechanical visual indicator of the spring compression is included.

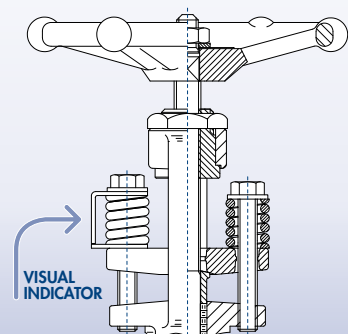

SWING CHECK VALVES

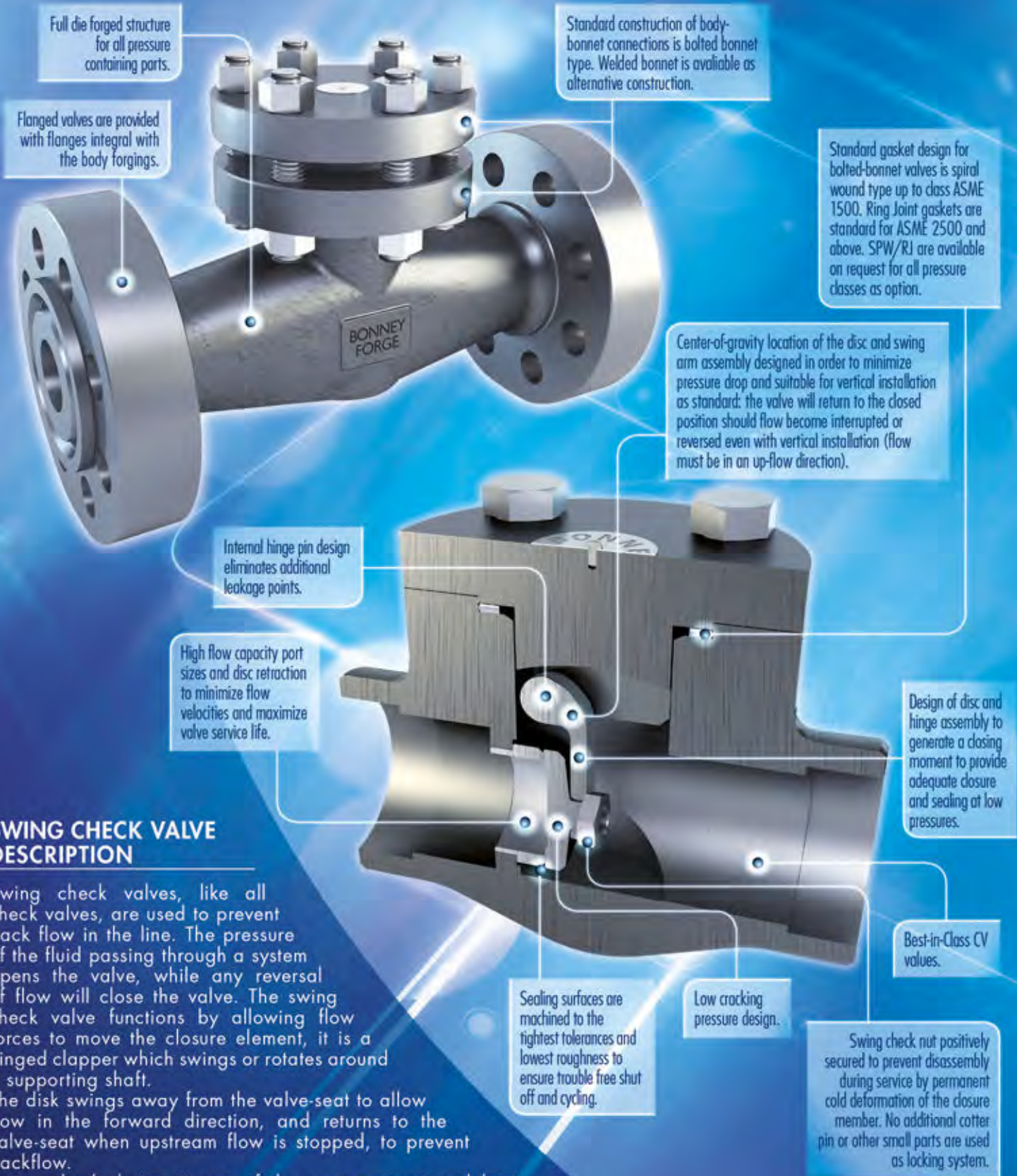

SWING CHECK VALVE DESCRIPTION

Swing check valves, like all check valves, are used to prevent back flow in the line. The pressure of the fluid passing through a system opens the valve, while any reversal of flow will close the valve. The swing check valve functions by allowing flow forces to move the closure element, it is a hinged clapper which swings or rotates around a supporting shaft.

The disk swings away from the valve-seat to allow flow in the forward direction, and returns to the valve-seat when upstream flow is stopped, to prevent backflow.

Swing check design is one of the most common and best check valve for general-purpose use. These valves produce the lowest pressure drop, when compared with other check valves of the same size, the internal contours and shapes allow them to fully open at low fluid velocities and create a smooth flow path through the valve.

The design is simple and easy to maintain and can be used for either horizontal or vertical (fluid flowing upward) pipe layouts. Because of their design, swing checks are not fast-closing valves due to the travel distance from full open to close.

P&ID SYMBOL



STANDARD CONFIGURATIONS



SECTION INDEX OF SWING CHECK VALVES

PAGE	DESCRIPTION	SYM
E-3	BOLTED BONNET SWING CHECK VALVES	
	BASIC CONFIGURATION THREADED AND SOCKET WELD ENDS	
E-4	BOLTED BONNET SWING CHECK VALVES	
	BASIC CONFIGURATION ASME INTEGRAL FLANGED ENDS	
E-5	WELDED BONNET SWING CHECK VALVES	
	BASIC CONFIGURATION THREADED AND SOCKET WELD ENDS	
E-6	WELDED BONNET SWING CHECK VALVES	
	BASIC CONFIGURATION ASME INTEGRAL FLANGED ENDS	
E-7	AVAILABLE OPTIONS FOR SWING CHECK VALVES	

APPLICABLE STANDARDS	
DESIGN	API 602 - ISO 15761 - ASME B16.34
INSPECTION & TESTING	API 598
MARKING	MSS SP-25
RATING	ASME B16.34
FUGITIVE EMISSION	API 624 - ISO 15848

SWING CHECK VALVES

BOLTED BONNET SWING CHECK VALVES BASIC CONFIGURATION THREADED AND SOCKET WELD ENDS



WORKING PRESSURE RATING	SIZE		STANDARD DESIGN TYPE	A		B		H		WEIGHT		FIGURE
	NPS	DN		mm	in	mm	in	mm	in	kg	lb	
ASME 800	1/2"	15	S1	80	3.15	9.6	0.4	55	2.17	1.3	2.9	HL 603
	3/4"	20	S1	90	3.54	14	0.6	60	2.36	1.6	3.5	HL 604
	1"	25	S1	110	4.33	18	0.7	78	3.07	2.8	6.2	HL 605
	1-1/2"	40	S1	150	5.91	30	1.2	92	3.62	5.6	12.3	HL 607
	2"	50	S1	180	7.09	36.6	1.4	108	4.25	9	19.8	HL 608
ASME 1500	1/2"	15	S1	90	3.54	9.6	0.4	60	2.36	1.7	3.7	9HL 603
	3/4"	20	S1	110	4.33	14	0.6	78	3.07	3	6.6	9HL 604
	1"	25	S1	127	5.00	18	0.7	88	3.46	4.4	9.7	9HL 605
	1-1/2"	40	S1	180	7.09	30	1.2	108	4.25	10	22.0	9HL 607
	2"	50	S1	210	8.27	36.6	1.4	145	5.71	18	39.7	9HL 608
ASME 800	1/4"	6	S1	80	3.15	8	0.3	55	2.17	1.4	3.1	H 601
	3/8"	10	S1	80	3.15	9.6	0.4	55	2.17	1.4	3.1	H 602
	1/2"	15	S1	90	3.54	14	0.6	60	2.36	1.6	3.5	H 603
	3/4"	20	S1	110	4.33	18	0.7	78	3.07	3	6.6	H 604
	1"	25	S1	127	5.00	24	0.9	88	3.46	4.3	9.5	H 605
	1-1/4"	32	S1	150	5.91	30	1.2	92	3.62	5.6	12.3	H 606
	1-1/2"	40	S1	180	7.09	36.6	1.4	108	4.25	10	22.0	H 607
	2"	50	S1	210	8.27	48	1.9	145	5.71	16	35.3	H 608
ASME 1500	1/2"	15	S1	110	4.33	14	0.6	78	3.07	3.1	6.8	9H 603
	3/4"	20	S1	127	5.00	18	0.7	88	3.46	4.6	10.1	9H 604
	1"	25	S1	150	5.91	24	0.9	92	3.62	6.5	14.3	9H 605
	1-1/4"	32	S1	180	7.09	30	1.2	108	4.25	10.6	23.4	9H 606
	1-1/2"	40	S1	210	8.27	36.6	1.4	145	5.71	19	41.9	9H 607
	2"	50	S1	210	8.27	48	1.9	150	5.91	19	41.9	9H 608
ASME 2500	1/2"	15	S2	150	5.91	11.5	0.5	128	5.04	7.5	16.5	25HR 603
	3/4"	20	S2	150	5.91	15	0.6	128	5.04	7.5	16.5	25HR 604
	1"	25	S2	210	8.27	19.5	0.8	152	5.98	18.5	40.8	25HR 605
	1-1/2"	40	S2	230	9.06	28	1.1	190	7.48	30	66.1	25HR 607
2"	50	S2	230	9.06	35	1.4	190	7.48	30	66.1	25HR 608	

STANDARD BORE

FULL BORE

BPE reserves the right to change designs, dimensions or specifications without notice.

PRODUCT FEATURES:

- Internal Pin Design.

DESIGN TYPE S1

SPIRAL WOUND GASKET BODY-BONNET CONNECTION

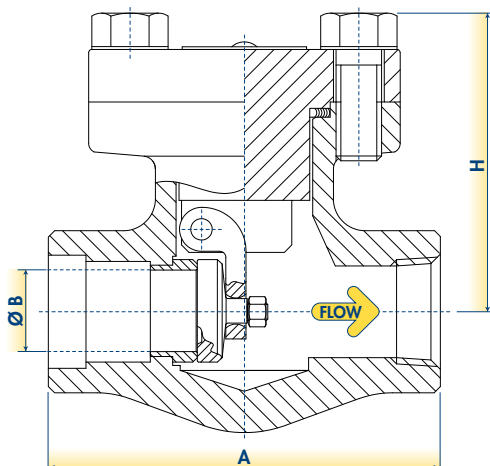

DESIGN TYPE S2

RING JOINT BODY-BONNET CONNECTION

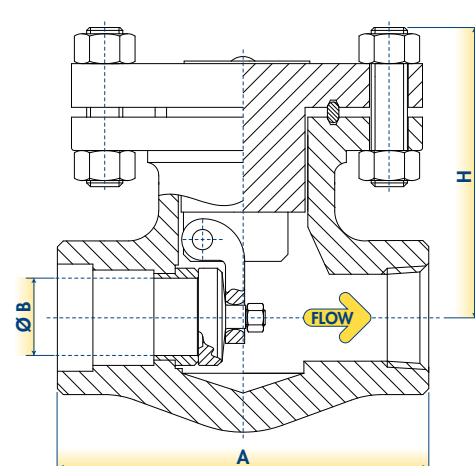

BOLTED BONNET SWING CHECK VALVES BASIC CONFIGURATION ASME INTEGRAL FLANGED ENDS



WORKING PRESSURE RATING	SIZE		STANDARD DESIGN TYPE	A-RF		A-RJ		B		H		WEIGHT		FIGURE	
	NPS	DN		mm	in	mm	in	mm	in	mm	in	kg	lb		
ASME 150	1/2"	15	S1	108	4.25	N.A.	N.A.	9.6	0.38	75	3.0	2.2	4.9	L1-603	STANDARD BORE
	3/4"	20	S1	117.5	4.63	N.A.	N.A.	14	0.55	75	3.0	3.1	6.8	L1-604	
	1"	25	S1	127	5.00	140	5.51	17.5	0.69	85	3.3	4.4	9.7	L1-605	
	1-1/2"	40	S1	165	6.50	178	7.01	29.5	1.16	110	4.3	8.3	18.3	L1-607	
	2"	50	S1	203	7.99	216	8.50	36.6	1.44	125	4.9	13	28.7	L1-608	
ASME 300	1/2"	15	S1	152.5	6.00	163.5	N.A.	9.6	0.38	75	3.0	3.3	7.3	L3-603	
	3/4"	20	S1	178	7.01	178	7.01	14	0.55	80	3.1	5.2	11.5	L3-604	
	1"	25	S1	216	8.50	216	8.50	17.5	0.69	88	3.5	7.4	16.3	L3-605	
	1-1/2"	40	S1	241	9.49	254	10.00	29.5	1.16	115	4.5	13.5	29.8	L3-607	
	2"	50	S1	267	10.51	283	11.14	36.6	1.44	130	5.1	19	41.9	L3-608	
ASME 600	1/2"	15	S1	165	6.50	163	6.42	9.6	0.38	72	2.8	3.5	7.7	L6-603	
	3/4"	20	S1	191	7.52	191	7.52	14	0.55	80	3.1	5.7	12.6	L6-604	
	1"	25	S1	216	8.50	216	8.50	17.5	0.69	85	3.3	8	17.6	L6-605	
	1-1/2"	40	S1	241	9.49	241	9.49	29.5	1.16	115	4.5	14.5	32.0	L6-607	
	2"	50	S1	292	11.50	295	11.61	36.6	1.44	130	5.1	19.5	43.0	L6-608	
ASME 150	1/2"	15	S1	108	4.25	N.A.	N.A.	14	0.55	75	3.0	2.8	6.2	1-603	FULL BORE
	3/4"	20	S1	117	4.61	N.A.	N.A.	18	0.71	85	3.3	3.6	7.9	1-604	
	1"	25	S1	127	5.00	140	5.51	24	0.94	100	3.9	5.2	11.5	1-605	
	1-1/2"	40	S1	165	6.50	178	7.01	36.6	1.44	125	4.9	10	22.0	1-607	
	2"	50	S1	203	7.99	216	8.50	48	1.89	140	5.5	16	35.3	1-608	
ASME 300	1/2"	15	S1	152.5	6.00	N.A.	N.A.	14	0.55	75	3.0	3.6	7.9	3-603	
	3/4"	20	S1	178	N.A.	178	N.A.	18	0.71	90	3.5	6.4	14.1	3-604	
	1"	25	S1	216	8.50	229	9.02	24	0.94	100	3.9	8.2	18.1	3-605	
	1-1/2"	40	S1	241	9.49	254	10.00	36.6	1.44	120	4.7	15	33.1	3-607	
	2"	50	S1	267	10.51	283	11.14	48	1.89	150	5.9	21	46.3	3-608	
ASME 600	1/2"	15	S1	165	6.50	163	6.42	14	0.55	75	3.0	3.8	8.4	6-603	
	3/4"	20	S1	191	7.52	191	7.52	18	0.71	90	3.5	6.5	14.3	6-604	
	1"	25	S1	216	8.50	216	8.50	24	0.94	100	3.9	8.5	18.7	6-605	
	1-1/2"	40	S1	241	9.49	241	9.49	36.6	1.44	120	4.7	16	35.3	6-607	
	2"	50	S1	292	11.50	295	11.61	48	1.89	150	5.9	23	50.7	6-608	
ASME 1500	1/2"	15	S1	216	8.50	216	8.50	14	0.55	105	4.1	7.5	16.5	15F 603	
	3/4"	20	S1	229	9.02	229	9.02	18	0.71	125	4.9	11.2	24.7	15F 604	
	1"	25	S1	254	10.00	254	10.00	24	0.94	135	5.3	14.5	32.0	15F 605	
	1-1/2"	40	S1	305	12.01	305	12.01	36.6	1.44	155	6.1	26.5	58.4	15F 607	
	2"	50	S1	368	14.49	371	14.61	48	1.89	195	7.7	50	110.2	15F 608	
ASME 2500	1/2"	15	S2	264	10.39	264	10.39	11.5	0.45	128	5.0	14.3	31.5	25RF 603	
	3/4"	20	S2	273	10.75	273	10.75	15	0.59	130	5.1	16	35.3	25RF 604	
	1"	25	S2	308	12.13	308	12.13	19.5	0.77	152	6.0	26.3	58.0	25RF 605	
	1-1/2"	40	S2	384	15.12	387	15.24	28	1.10	188	7.4	54	119.0	25RF 607	
	2"	50	S2	451	17.76	454	17.87	35	1.38	190	7.5	56	123.5	25RF 608	

B/E reserves the right to change designs, dimensions or specifications without notice.

PRODUCT FEATURES:

- Internal Pin Design. • Integral body flanges.

DESIGN TYPE S1

SPIRAL WOUND GASKET BODY-BONNET CONNECTION

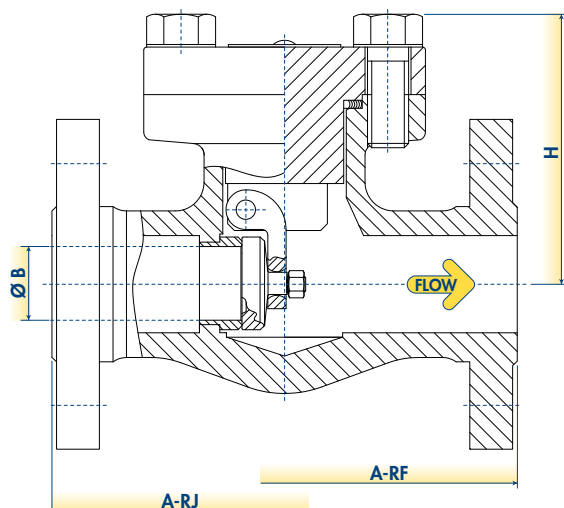

DESIGN TYPE S2

RING JOINT BODY-BONNET CONNECTION

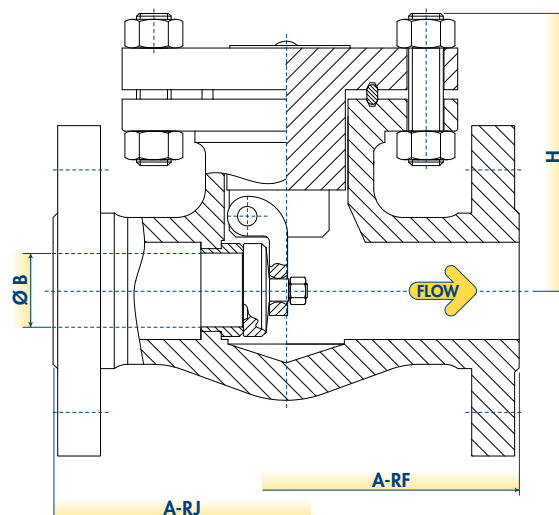

SWING CHECK VALVES

WELDED BONNET SWING CHECK VALVES BASIC CONFIGURATION THREADED AND SOCKET WELD ENDS



WORKING PRESSURE RATING	SIZE	DN	STANDARD DESIGN TYPE	A		B		H		WEIGHT		FIGURE		
				mm	in	mm	in	mm	in	kg	lb			
ASME 800	1/2"	15	W3	80	3.15	9.6	0.4	54	2.13	0.9	2.0	HWL 603	STANDARD BORE	
	3/4"	20	W3	90	3.54	14	0.6	60	2.36	1.1	2.4	HWL 604		
	1"	25	W3	110	4.33	18	0.7	76	2.99	2.3	5.1	HWL 605		
	1-1/2"	40	W3	150	5.91	30	1.2	92	3.62	5	11.0	HWL 607		
	2"	50	W3	127	5.00	36.6	1.4	110	4.33	8.3	18.3	HWL 608		
ASME 1500	1/2"	15	W3	90	3.54	9.6	0.4	54	2.13	1.4	3.1	9HWL 603		
	3/4"	20	W3	110	4.33	14	0.6	76	2.99	2.2	4.9	9HWL 604		
	1"	25	W3	127	5.00	18	0.7	86	3.39	3	6.6	9HWL 605		
	1-1/2"	40	W3	180	7.09	30	1.2	110	4.33	9.6	21.2	9HWL 607		
	2"	50	W3	210	8.27	36.6	1.4	150	5.91	16	35.3	9HWL 608		
ASME 800	1/4"	6	W3	80	3.15	8	0.3	55	2.17	1	2.2	HW 601		FULL BORE
	3/8"	10	W3	80	3.15	9.6	0.4	55	2.17	1	2.2	HW 602		
	1/2"	15	W3	90	3.54	14	0.6	60	2.36	1.2	2.6	HW 603		
	3/4"	20	W3	110	4.33	18	0.7	78	3.07	2.3	5.1	HW 604		
	1"	25	W3	127	5.00	24	0.9	88	3.46	3.3	7.3	HW 605		
	1-1/4"	32	W3	150	5.91	30	1.2	92	3.62	5.2	11.5	HW 606		
	1-1/2"	40	W3	180	7.09	36.6	1.4	110	4.33	8.7	19.2	HW 607		
	2"	50	W3	210	8.27	48	1.9	150	5.91	14	30.9	HW 608		
ASME 1500	1/4"	6	W3	90	3.54	8	0.3	55	2.17	1.4	3.1	9HW 601		
	3/8"	10	W3	90	3.54	9.6	0.4	55	2.17	1.4	3.1	9HW 602		
	1/2"	15	W3	110	4.33	14	0.6	76	2.99	2.5	5.5	9HW 603		
	3/4"	20	W3	127	5.00	18	0.7	84	3.31	3.7	8.2	9HW 604		
	1"	25	W3	127	5.00	24	0.9	90	3.54	6	13.2	9HW 605		
	1-1/4"	32	W3	127	5.00	30	1.2	110	4.33	10	22.0	9HW 606		
	1-1/2"	40	W3	210	8.27	36.6	1.4	150	5.91	15.5	34.2	9HW 607		
	2"	50	W3	230	9.06	48	1.9	230	9.06	22	48.5	9HW 608		
ASME 2500	1/4"	6	W3	110	4.33	8	0.3	70	2.76	3.2	7.1	25HW 601		
	3/8"	10	W3	110	4.33	8	0.3	70	2.76	3.2	7.1	25HW 602		
	1/2"	15	W3	127	5.00	11.5	0.5	86	3.39	3.8	8.4	25HW 603		
	3/4"	20	W3	127	5.00	15	0.6	92	3.62	5.6	12.3	25HW 604		
	1"	25	W3	127	5.00	19.5	0.8	110	4.33	10	22.0	25HW 605		
	1-1/4"	32	W3	127	5.00	25	1.0	130	5.12	13	28.7	25HW 606		
	1-1/2"	40	W3	210	8.27	28	1.1	150	5.91	16	35.3	25HW 607		
	2"	50	W3	230	9.06	38	1.5	180	7.09	21	46.3	25HW 608		

BFE reserves the right to change designs, dimensions or specifications without notice.

PRODUCT FEATURES:

- Internal Pin Design.
- Body-Bonnet weld to ASME IX.

DESIGN TYPE W3 FULL PENETRATION WELD BODY-BONNET CONNECTION

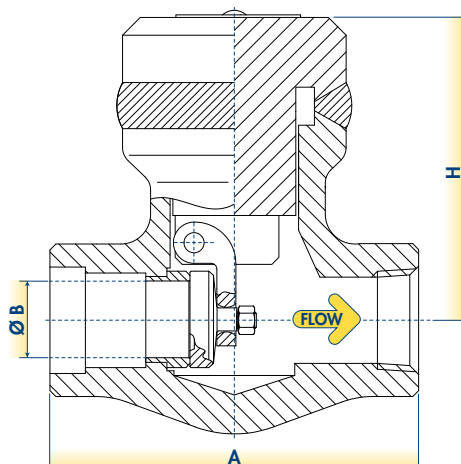

SWING CHECK VALVES

WELDED BONNET SWING CHECK VALVES BASIC CONFIGURATION ASME INTEGRAL FLANGED ENDS



WORKING PRESSURE RATING	SIZE		STANDARD DESIGN TYPE	A-RF		A-RJ		B		H		WEIGHT		FIGURE
	NPS	DN		mm	in	mm	in	mm	in	mm	in	kg	lb	
ASME 150	1/2"	15	W3	108	4.25	N.A.	N.A.	9.6	0.38	75	3.0	2.1	4.6	1HWL 603
	3/4"	20	W3	117.5	4.63	N.A.	N.A.	14	0.55	75	3.0	2.9	6.5	1HWL 604
	1"	25	W3	127	5.00	140	5.51	17.5	0.69	85	3.3	4.2	9.2	1HWL 605
	1-1/2"	40	W3	165	6.50	178	7.01	29.5	1.16	110	4.3	7.9	17.4	1HWL 607
	2"	50	W3	203	7.99	216	8.50	36.6	1.44	125	4.9	12.4	27.2	1HWL 608
ASME 300	1/2"	15	W3	152.5	6.00	163.5	N.A.	9.6	0.38	75	3.0	3.1	6.9	3HWL 603
	3/4"	20	W3	178	7.01	178	7.01	14	0.55	80	3.1	4.9	10.9	3HWL 604
	1"	25	W3	216	8.50	216	8.50	17.5	0.69	88	3.5	7.0	15.5	3HWL 605
	1-1/2"	40	W3	241	9.49	254	10.00	29.5	1.16	115	4.5	12.8	28.3	3HWL 607
	2"	50	W3	267	10.51	283	11.14	36.6	1.44	130	5.1	18.1	39.8	3HWL 608
ASME 600	1/2"	15	W3	165	6.50	163	6.42	9.6	0.38	72	2.8	3.3	7.3	6HWL 603
	3/4"	20	W3	191	7.52	191	7.52	14	0.55	80	3.1	5.4	11.9	6HWL 604
	1"	25	W3	216	8.50	216	8.50	17.5	0.69	85	3.3	7.6	16.8	6HWL 605
	1-1/2"	40	W3	241	9.49	241	9.49	29.5	1.16	115	4.5	13.8	30.4	6HWL 607
	2"	50	W3	292	11.50	295	11.61	36.6	1.44	130	5.1	18.5	40.8	6HWL 608
ASME 150	1/2"	15	W3	108	4.25	N.A.	N.A.	14	0.55	75	3.0	2.7	5.9	1HW 603
	3/4"	20	W3	117	4.61	N.A.	N.A.	18	0.71	85	3.3	3.4	7.5	1HW 604
	1"	25	W3	127	5.00	140	5.51	24	0.94	100	3.9	4.9	10.9	1HW 605
	1-1/2"	40	W3	165	6.50	178	7.01	36.6	1.44	125	4.9	9.5	20.9	1HW 607
	2"	50	W3	203	7.99	216	8.50	48	1.89	140	5.5	15.2	33.5	1HW 608
ASME 300	1/2"	15	W3	152.5	6.00	N.A.	N.A.	14	0.55	75	3.0	3.4	7.5	3HW 603
	3/4"	20	W3	178	N.A.	178	N.A.	18	0.71	90	3.5	6.1	13.4	3HW 604
	1"	25	W3	216	8.50	229	9.02	24	0.94	100	3.9	7.8	17.2	3HW 605
	1-1/2"	40	W3	241	9.49	254	10.00	36.6	1.44	120	4.7	14.3	31.4	3HW 607
	2"	50	W3	267	10.51	283	11.14	48	1.89	150	5.9	20.0	44.0	3HW 608
ASME 600	1/2"	15	W3	165	6.50	163	6.42	14	0.55	75	3.0	3.6	8.0	6HW 603
	3/4"	20	W3	191	7.52	191	7.52	18	0.71	90	3.5	6.2	13.6	6HW 604
	1"	25	W3	216	8.50	216	8.50	24	0.94	100	3.9	8.1	17.8	6HW 605
	1-1/2"	40	W3	241	9.49	241	9.49	36.6	1.44	120	4.7	15.2	33.5	6HW 607
	2"	50	W3	292	11.50	295	11.61	48	1.89	150	5.9	21.9	48.2	6HW 608
ASME 1500	1/2"	15	W3	216	8.50	216	8.50	14	0.55	105	4.1	7.1	15.7	15HWF 603
	3/4"	20	W3	229	9.02	229	9.02	18	0.71	125	4.9	10.6	23.5	15HWF 604
	1"	25	W3	254	10.00	254	10.00	24	0.94	135	5.3	13.8	30.4	15HWF 605
	1-1/2"	40	W3	305	12.01	305	12.01	36.6	1.44	155	6.1	25.2	55.5	15HWF 607
	2"	50	W3	368	14.49	371	14.61	48	1.89	195	7.7	47.5	104.7	15HWF 608
ASME 2500	1/2"	15	W3	264	10.39	264	10.39	11.5	0.45	128	5.0	13.6	29.9	25HWF 603
	3/4"	20	W3	273	10.75	273	10.75	15	0.59	130	5.1	15.2	33.5	25HWF 604
	1"	25	W3	308	12.13	308	12.13	19.5	0.77	152	6.0	25.0	55.1	25HWF 605
	1-1/2"	40	W3	384	15.12	387	15.24	28	1.10	188	7.4	51.3	113.1	25HWF 607
	2"	50	W3	451	17.76	454	17.87	35	1.38	190	7.5	53.2	117.3	25HWF 608

STANDARD BORE

FULL BORE

BFE reserves the right to change designs, dimensions or specifications without notice.

PRODUCT FEATURES:

- Internal Pin Design.
- Body-Bonnet weld to ASME IX.
- Integral body flanges.

DESIGN TYPE W3

FULL PENETRATION WELD BODY-BONNET CONNECTION

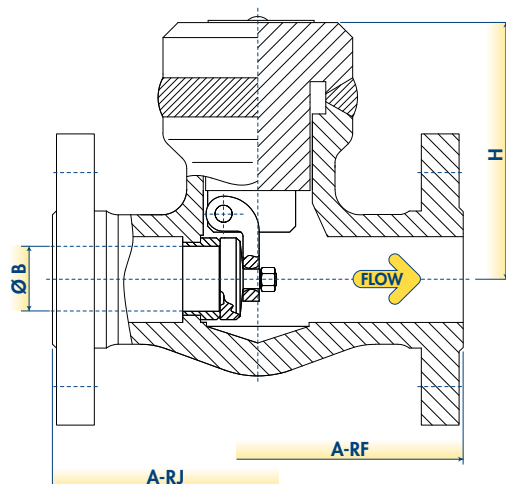

SWING CHECK VALVES

AVAILABLE OPTIONS FOR SWING CHECK VALVES OTHER VALVE OPTIONS OR CUSTOMISED VERSIONS ARE AVAILABLE ON REQUEST, CONTACT BFE FOR SPECIAL REQUIREMENTS.

TILTING DISC

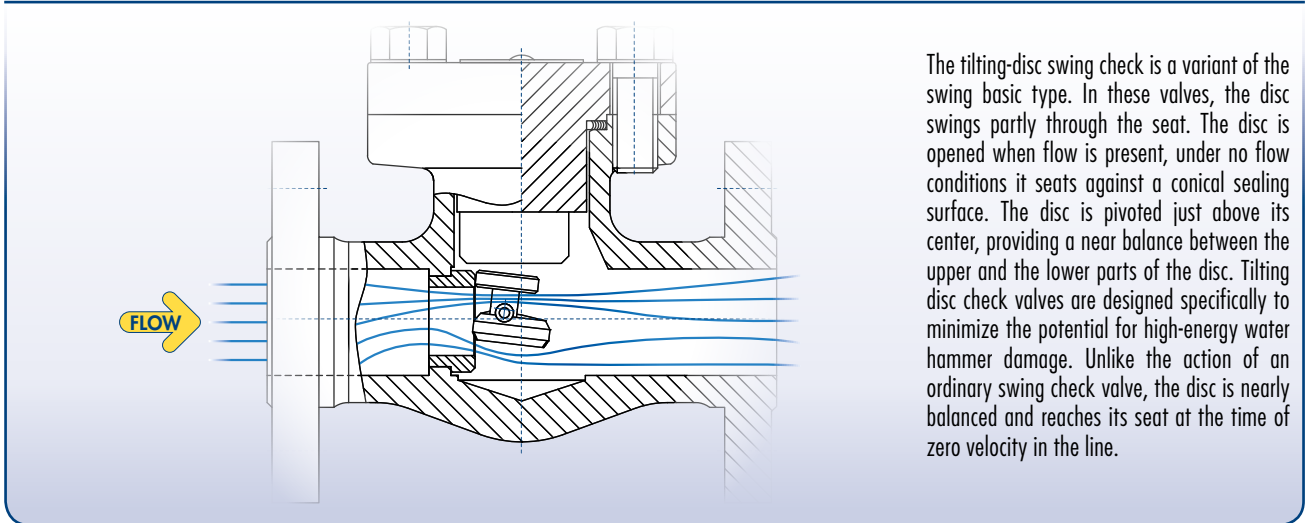

The tilting-disc swing check is a variant of the swing basic type. In these valves, the disc swings partly through the seat. The disc is opened when flow is present, under no flow conditions it seats against a conical sealing surface. The disc is pivoted just above its center, providing a near balance between the upper and the lower parts of the disc. Tilting disc check valves are designed specifically to minimize the potential for high-energy water hammer damage. Unlike the action of an ordinary swing check valve, the disc is nearly balanced and reaches its seat at the time of zero velocity in the line.

ALTERNATIVE CLOSURE MEMBER ANTI-LOOSENING SYSTEM

Swing check design must prevent possible unscrewing of the swing check closure member nut. BFE standard design achieves this goal is by cold upsetting of the closure member nut connection. Alternative solutions are available as an option, the most common alternative solution is obtained by an additional wire or pin that prevent loosening in service.

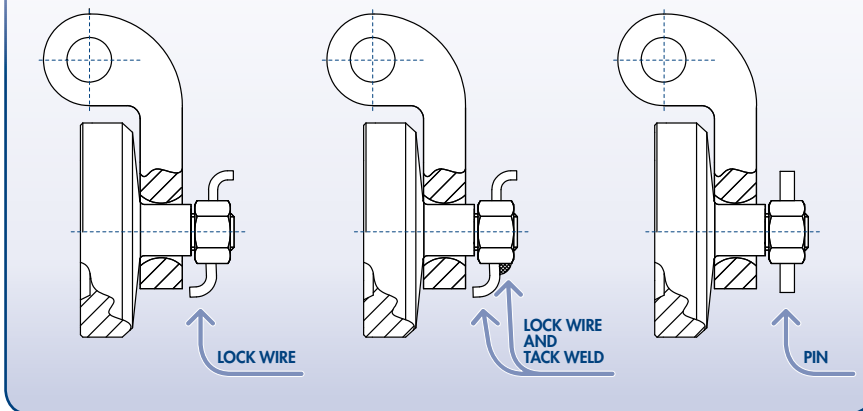

SPECIAL END FINISH

The choice of end connections for connecting a valve to its associated pipe is performed by customers. Common end finishes stated in the catalogue are socket, threaded, flanged (RF or RJ) and butt-weld ends. BFE is basically able to perform any end finish as per customer request, special end finish. Other end finishes as follows: hub, compact flange, any ASME B16.5 end finish other than RF and RJ, etc.

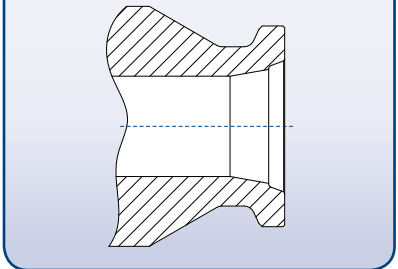

SOFT SEATED TRIM

In applications that require positive shut-off such as in chemical and petrochemical services, soft-seated swing check valve is a suitable solution because the use of soft-seat materials imparts excellent sealing ability. Soft seat inserts provide the necessary soft-seating to improve the leakproof design. Soft Insert can be obtained on the seat or on the closure member.

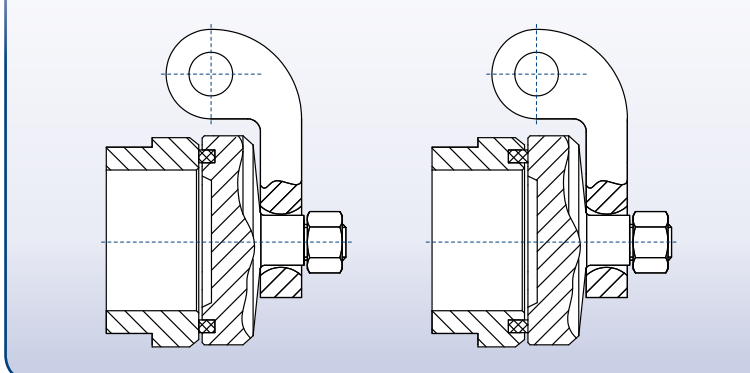

WEEP HOLE

The weep hole, is a small opening that allows the fluid to drain from the downstream side to the upstream in case of closed valve. Purpose of weep hole can depend from the application. In case of weep hole option the valve does not achieve leak-tight closing or keep the differential pressure.

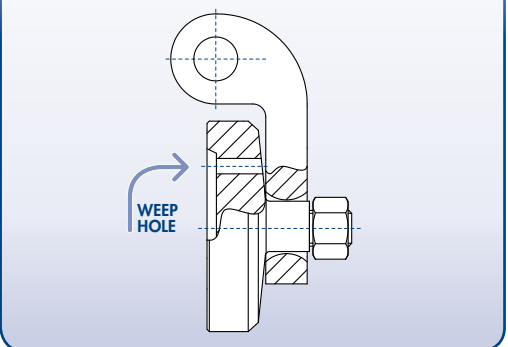

AVAILABLE OPTIONS FOR SWING CHECK VALVES

OTHER VALVE OPTIONS OR CUSTOMISED VERSIONS ARE AVAILABLE ON REQUEST, CONTACT BFE FOR SPECIAL REQUIREMENTS.

TIE ROD PACKAGING SET

A tie rod is a slender structural unit used as a tie and (in most applications) capable of carrying tensile loads only. Tie Rod Packaging is used to help protect trim of check valves during shipment. It is common for a transport package to be dropped, kicked, and impacted: These events may produce potentially damaging shocks of the seal surfaces. Shock and vibration are controlled by the tie rod geometry that block the closure member in open position so that the chance of product damage is greatly reduced. The soft insert can be manufactured from elastomer, polymers and similar resilient or semi-resilient materials.

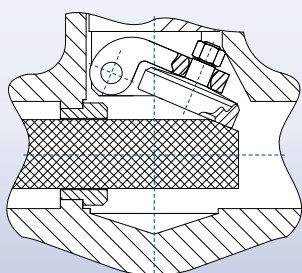

AUXILIARY STANDARD DRAIN

Swing check valves can be furnished with drain. Standard drain connections consist of a drilled, tapped, and plugged hole at the ASME B16.34 "G" location. Other types of drains, including welding, or threaded nipples, can also be furnished when specified.

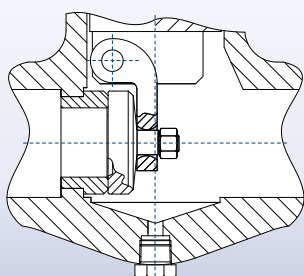

EYEBOLT FOR HANDLING

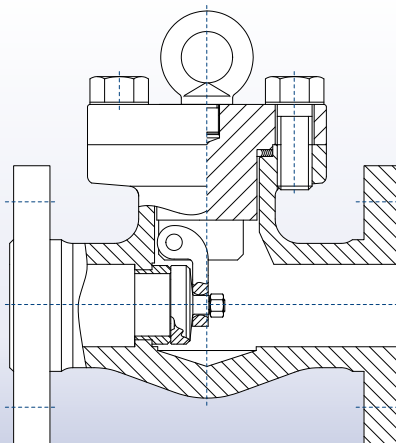

Small size swing check valves does not require lifting eyebolts as standard because of the low weight. Handling is normally performed on small valves by lifting with eye bolts or rods through flange holes. If required the bonnet design can be modified in order to include one screwed lifting eye bolts screwed on the top to facilitate valve installation into the piping system.

SPECIAL DRAIN OR VENT LINE

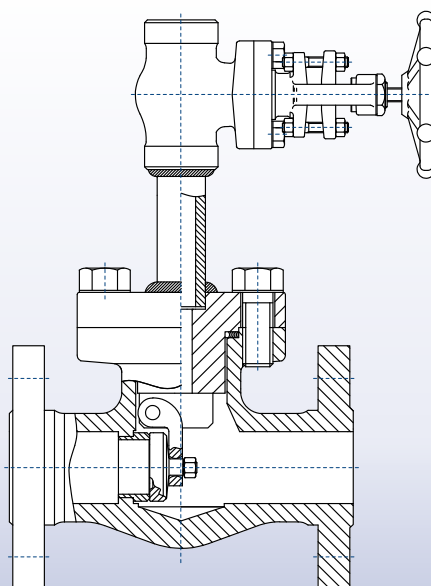

The removal of fluid in pipelines can be a frequent operation for some oil&gas industry applications. The drain/vent line can be added to the swing check design based on the customer requirements. Connections can be provided with permanent block valves, including plugs or blinds.

LOW FLOW RATE NON-RETURN VALVE

Special design and material selection can be performed to eliminate valve chattering. This is a common problem with valves operating in or around the flow-rate and fluid specific mass range the valve is designed to open at. In systems using conventional valves, oscillation caused harmonics in the system create problems related to noise, damage to the valve seats, localized air bubbles etc. Special design based on the flow operating conditions and proper low density material selection eliminate chatter problems.

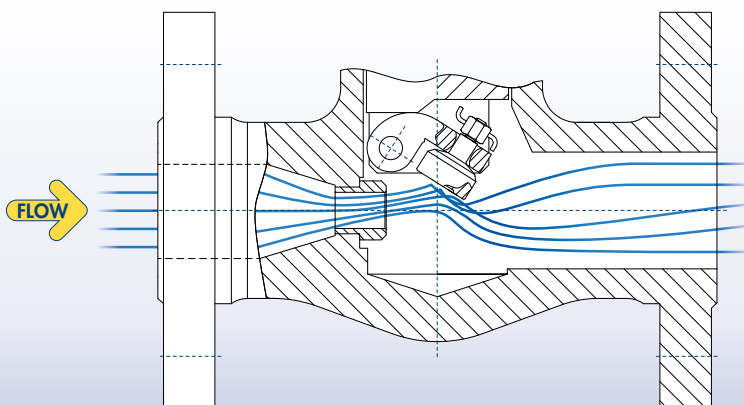

PISTON & BALL CHECK VALVES



Full die forged structure for all pressure containing parts.

Flanged valves are provided with flanges integral with the body forgings.

Standard construction of body-bonnet connections is bolted bonnet type. Welded bonnet is available as alternative construction.

Standard gasket design for bolted-bonnet valves is spiral wound type up to class ASME 1500. Ring Joint gaskets are standard for ASME 2500 and above. SPW/RJ are available on request for all pressure classes as option.

Sealing surfaces are machined to the tightest tolerances and lowest roughness to ensure trouble free shut off.

Body-guided disc for perfect seat and disc alignment. Disc is machined to the tightest tolerances to ensure trouble free shutoff and cycling.

Precision guided closure member for perfect seating surfaces alignment.

Closure member can be spring loaded for positive closure in any position.

PISTON & BALL CHECK VALVE DESCRIPTION

Piston and ball check valves, like all check valves, are used to prevent back flow in the line. Standard valve design has no spring in order to minimize cracking pressure and pressure drop, it will only function properly when installed in a horizontal line. As an option the designs can include a spring to assist closing and for use in 90-degree styles installed in vertical lines.

PISTON CHECK VALVE

The pressure of the fluid passing through a system opens the valve, while any reversal of flow will close the valve. In Piston, or lift, check valves a body-guided disc moves within the body bore. The body guide ensures alignment of the seat and disc when the valve closes. The valve is installed with the flow under the disc, so that the inlet line pressure and flow rate will force the disc to "lift" off the seat and allow the line fluid to flow through the valve. Should the flow suddenly reverse itself, the disc will automatically and quickly, assisted by the weight of the disc, be forced to the closed position, preventing the line fluid from returning. Exercise caution when these valves are used for dirty media because that media could cause the disc to stick inside the body bore.

BALL CHECK VALVE

The function of ball check valves is similar to the piston check, but the ball check valves use a "ball" inside the body to control the movement of flow. The ball is free to rotate, resulting in even wear and a wiping action between the ball and seat. This feature makes ball checks useful for viscous media.

High flow capacity port sizes and disc retraction to minimize flow velocities and maximize valve service life.

Low cracking pressure design.

Fast response time to prevent backflow and adequate valve seating to prevent seat slamming.

Standard seat design is screwed-in type, integral type is available as alternative construction or in case of bolted bonnet design. Extra thickness of the seat ring provides sufficient material to renew the seating surface over and over again.













P&ID SYMBOL



STANDARD CONFIGURATIONS



SECTION INDEX OF PISTON AND BALL CHECK VALVES

PAGE	DESCRIPTION	SYM
F-3	BOLTED BONNET PISTON & BALL CHECK VALVES BASIC CONFIGURATION	
	 THREADED AND SOCKET WELD ENDS	
F-4	BOLTED BONNET PISTON & BALL CHECK VALVES BASIC CONFIGURATION	
	 ASME INTEGRAL FLANGED ENDS	
F-5	WELDED BONNET PISTON & BALL CHECK VALVES BASIC CONFIGURATION	
	 THREADED AND SOCKET WELD ENDS	
F-6	WELDED BONNET PISTON & BALL CHECK VALVES BASIC CONFIGURATION	
	 ASME INTEGRAL FLANGED ENDS	
F-7	AVAILABLE OPTIONS FOR PISTON & BALL CHECK VALVES	

APPLICABLE STANDARDS	
DESIGN	API 602 - ISO 15761 - ASME B16.34
INSPECTION & TESTING	API 598
MARKING	MSS SP-25
RATING	ASME B16.34
FUGITIVE EMISSION	API 624 - ISO 15848

PISTON & BALL CHECK VALVES

BOLTED BONNET PISTON & BALL CHECK VALVES BASIC CONFIGURATION THREADED AND SOCKET WELD ENDS



WORKING PRESSURE RATING	SIZE		STANDARD DESIGN TYPE	A		B		H		WEIGHT		FIGURE PISTON CHECK	FIGURE BALL CHECK
	NPS	DN		mm	in	mm	in	mm	in	kg	lb		
ASME 800	1/2"	15	S1	80	3.15	9	0.35	55	2.17	1.3	2.9	HL 403	HL 503
	3/4"	20	S1	90	3.54	13	0.51	60	2.36	1.6	3.5	HL 404	HL 504
	1"	25	S1	110	4.33	17	0.66	78	3.07	2.8	6.2	HL 405	HL 505
	1-1/2"	40	S1	150	5.91	29	1.14	92	3.62	5.6	12.3	HL 407	HL 507
	2"	50	S1	180	7.09	35	1.38	108	4.25	9	19.8	HL 408	HL 508
ASME 1500	1/2"	15	S1	90	3.54	9	0.35	60	2.36	1.7	3.7	9HL 403	9HL 503
	3/4"	20	S1	110	4.33	12	0.47	78	3.07	3	6.6	9HL 404	9HL 504
	1"	25	S1	127	5.00	15	0.59	88	3.46	4.4	9.7	9HL 405	9HL 505
	1-1/2"	40	S1	180	7.09	27	1.06	108	4.25	10	22.0	9HL 407	9HL 507
	2"	50	S1	210	8.27	32	1.26	145	5.71	18	39.7	9HL 408	9HL 508
ASME 800	1/4"	6	S1	80	3.15	7	0.28	55	2.17	1.4	3.1	H 401	H 501
	3/8"	10	S1	80	3.15	9	0.35	55	2.17	1.4	3.1	H 402	H 502
	1/2"	15	S1	90	3.54	13	0.51	60	2.36	1.6	3.5	H 403	H 503
	3/4"	20	S1	110	4.33	17	0.66	78	3.07	3	6.6	H 404	H 504
	1"	25	S1	127	5.00	22	0.86	88	3.46	4.3	9.5	H 405	H 505
	1-1/4"	32	S1	150	5.91	29	1.14	92	3.62	5.6	12.3	H 406	H 506
	1-1/2"	40	S1	180	7.09	35	1.38	108	4.25	10	22.0	H 407	H 507
	2"	50	S1	210	8.27	45	1.77	145	5.71	16	35.3	H 408	H 508
ASME 1500	1/4"	6	S1	90	3.54	7	0.28	60	2.36	1.7	3.7	9H 401	9H 501
	3/8"	10	S1	90	3.54	9	0.35	60	2.36	1.7	3.7	9H 402	9H 502
	1/2"	15	S1	110	4.33	12	0.47	78	3.07	3.1	6.8	9H 403	9H 503
	3/4"	20	S1	127	5.00	15	0.59	88	3.46	4.6	10.1	9H 404	9H 504
	1"	25	S1	150	5.91	20	0.79	92	3.62	6.5	14.3	9H 405	9H 505
	1-1/4"	32	S1	180	7.09	27	1.06	108	4.25	10.6	23.4	9H 406	9H 506
	1-1/2"	40	S1	210	8.27	32	1.26	145	5.71	19	41.9	9H 407	9H 507
	2"	50	S1	210	8.27	38	1.50	150	5.91	19	41.9	9H 408	9H 508
ASME 2500	1/2"	15	S2	150	5.91	11	0.43	128	5.04	7.5	16.5	25HR 403	25HR 503
	3/4"	20	S2	150	5.91	14.5	0.57	128	5.04	7.5	16.5	25HR 404	25HR 504
	1"	25	S2	210	8.27	19	0.75	152	5.98	18.5	40.8	25HR 405	25HR 505
	1-1/2"	40	S2	230	9.06	28	1.10	190	7.48	30	66.1	25HR 407	25HR 507
	2"	50	S2	230	9.06	38	1.50	190	7.48	30	66.1	25HR 408	25HR 508

BFE reserves the right to change designs, dimensions or specifications without notice.

PRODUCT FEATURES:

- Body-Bonnet weld to ASME IX

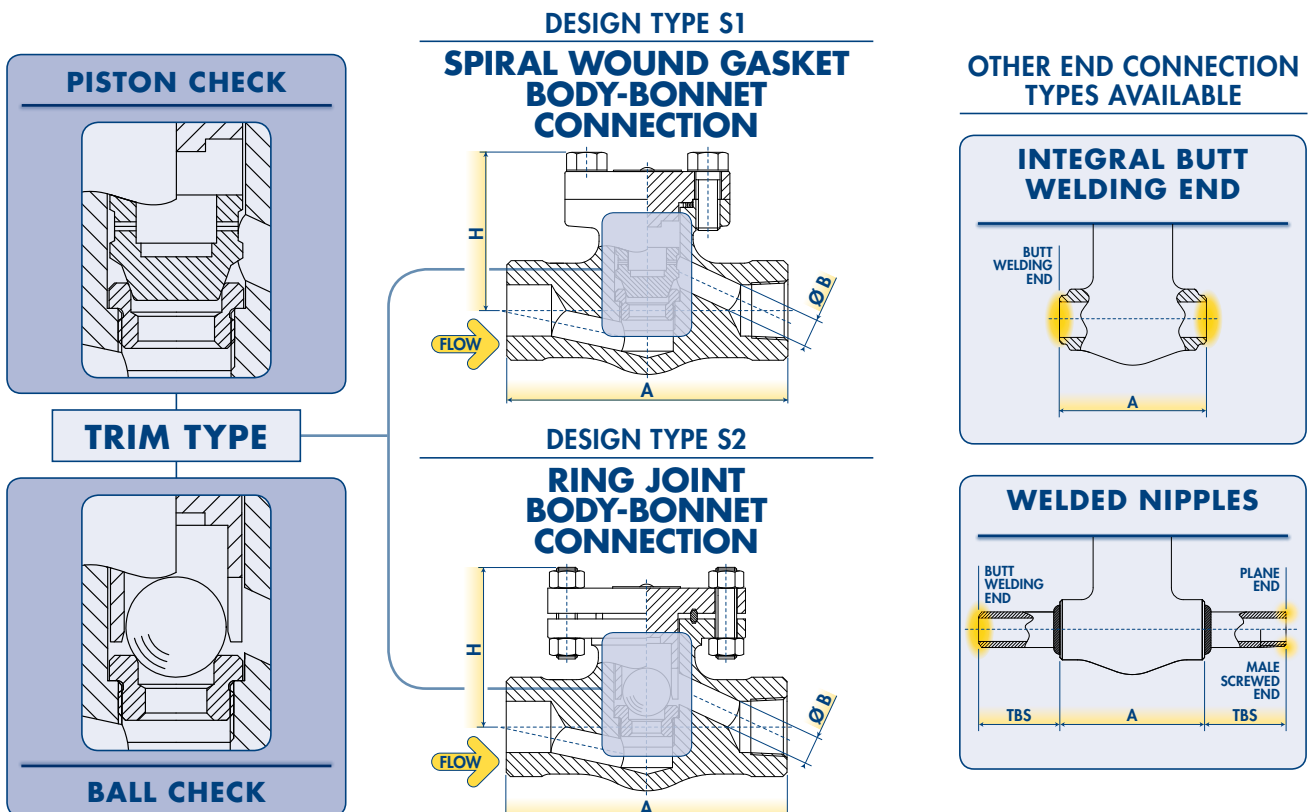

PISTON & BALL CHECK VALVES

BOLTED BONNET PISTON & BALL CHECK VALVES BASIC CONFIGURATION ASME INTEGRAL FLANGED ENDS



WORKING PRESSURE RATING	SIZE		STANDARD DESIGN TYPE	A-RF		A-RJ		B		H		WEIGHT		FIGURE PISTON CHECK	FIGURE BALL CHECK		
	NPS	DN		mm	in	mm	in	mm	in	mm	in	kg	lb				
ASME 150	1/2"	15	S1	108	4.25	N.A.	N.A.	10	0.39	75	3.0	2.3	5.1	L1-403	L1-503	STANDARD BORE	
	3/4"	20	S1	117.5	4.63	N.A.	N.A.	14	0.55	75	3.0	3.1	6.8	L1-404	L1-504		
	1"	25	S1	127	5.00	140	5.51	17	0.66	85	3.3	4.5	9.9	L1-405	L1-505		
	1-1/2"	40	S1	165	6.50	178	7.01	29	1.14	110	4.3	8.4	18.5	L1-407	L1-507		
	2"	50	S1	203	7.99	216	8.50	35	1.38	125	4.9	14	30.9	L1-408	L1-508		
ASME 300	1/2"	15	S1	152.5	6.00	163.6	6.44	9	0.35	75	3.0	3.4	7.5	L3-403	L3-503		FULL BORE
	3/4"	20	S1	178	7.01	190.5	7.50	13	0.51	80	3.1	5.3	11.7	L3-404	L3-504		
	1"	25	S1	203	7.99	216	8.50	17	0.66	88	3.5	7.5	16.5	L3-405	L3-505		
	1-1/2"	40	S1	229	9.02	241	9.49	29	1.14	115	4.5	14	30.9	L3-407	L3-507		
	2"	50	S1	267	10.51	282.5	11.12	35	1.38	130	5.1	19	41.9	L3-408	L3-508		
ASME 600	1/2"	15	S1	165	6.50	163.5	6.44	9	0.35	72	2.8	3.5	7.7	L6-403	L6-503	STANDARD BORE	
	3/4"	20	S1	191	7.52	190.5	7.50	13	0.51	80	3.1	5.7	12.6	L6-404	L6-504		
	1"	25	S1	216	8.50	216	8.50	17	0.66	85	3.3	8	17.6	L6-405	L6-505		
	1-1/2"	40	S1	241	9.49	241	9.49	29	1.14	115	4.5	14.5	32.0	L6-407	L6-507		
	2"	50	S1	292	11.50	295	11.61	35	1.38	130	5.1	19.5	43.0	L6-408	L6-508		
ASME 1500	1/2"	15	S1	216	8.50	216	8.50	9	0.35	85	3.3	6.5	14.3	15FL 403	15FL 503		FULL BORE
	3/4"	20	S1	229	9.02	229	9.02	14	0.55	100	3.9	10.2	22.5	15FL 404	15FL 504		
	1"	25	S1	254	10.00	254	10.00	14	0.55	105	4.1	13.5	29.8	15FL 405	15FL 505		
	1-1/2"	40	S1	305	12.01	305	12.01	26	1.02	125	4.9	25.5	56.2	15FL 407	15FL 507		
	2"	50	S1	368	14.49	371.5	14.63	34	1.34	165	6.5	49	108.0	15FL 408	15FL 508		
ASME 150	1/2"	15	S1	108	4.25	N.A.	N.A.	13	0.51	75	3.0	2.8	6.2	1-403	1-503	FULL BORE	
	3/4"	20	S1	117.5	4.63	N.A.	N.A.	17.5	0.69	85	3.3	3.6	7.9	1-404	1-504		
	1"	25	S1	127	5.00	140	5.51	22.5	0.89	100	3.9	5.2	11.5	1-405	1-505		
	1-1/2"	40	S1	165	6.50	178	7.01	35	1.38	125	4.9	10	22.0	1-407	1-507		
	2"	50	S1	203	7.99	216	8.50	45	1.77	140	5.5	16	35.3	1-408	1-508		
ASME 300	1/2"	15	S1	152.5	6.00	163.5	6.44	13	0.51	75	3.0	3.6	7.9	3-403	3-503		FULL BORE
	3/4"	20	S1	178	7.01	190.5	7.50	17.5	0.69	90	3.5	6.4	14.1	3-404	3-504		
	1"	25	S1	203	7.99	216	8.50	22.5	0.89	100	3.9	8.2	18.1	3-405	3-505		
	1-1/2"	40	S1	229	9.02	241	9.49	35	1.38	120	4.7	15	33.1	3-407	3-507		
	2"	50	S1	267	10.51	282.5	11.12	45	1.77	150	5.9	21	46.3	3-408	3-508		
ASME 600	1/2"	15	S1	165	6.50	163.5	6.44	13	0.51	75	3.0	3.8	8.4	6-403	6-503	FULL BORE	
	3/4"	20	S1	191	7.52	190.5	7.50	17.5	0.69	90	3.5	6.5	14.3	6-404	6-504		
	1"	25	S1	216	8.50	216	8.50	22.5	0.89	100	3.9	8.5	18.7	6-405	6-505		
	1-1/2"	40	S1	241	9.49	241	9.49	35	1.38	120	4.7	16	35.3	6-407	6-507		
	2"	50	S1	292	11.50	295	11.61	45	1.77	150	5.9	23	50.7	6-408	6-508		
ASME 1500	1/2"	15	S1	216	8.50	216	8.50	12	0.47	99	3.9	6.5	14.3	15F 403	15F 503		FULL BORE
	3/4"	20	S1	229	9.02	229	9.02	14.5	0.57	119	4.7	10.2	22.5	15F 404	15F 504		
	1"	25	S1	254	10.00	254	10.00	19	0.75	129	5.1	13.5	29.8	15F 405	15F 505		
	1-1/2"	40	S1	305	12.01	305	12.01	31	1.22	149	5.9	25.5	56.2	15F 407	15F 507		
	2"	50	S1	368	14.49	371.5	14.63	38	1.50	189	7.4	49	108.0	15F 408	15F 508		
ASME 2500	1/2"	15	S2	264	10.39	264	10.39	11	0.43	122	4.8	13.3	29.3	25RF 403	25RF 503	FULL BORE	
	3/4"	20	S2	273	10.75	273	10.75	14.5	0.57	124	4.9	15	33.1	25RF 404	25RF 504		
	1"	25	S2	308	12.13	308	12.13	19	0.75	146	5.7	25.3	55.8	25RF 405	25RF 505		
	1-1/2"	40	S2	384	15.12	387	15.24	28	1.10	182	7.2	53	116.8	25RF 407	25RF 507		
	2"	50	S2	451	17.76	454	17.87	35	1.38	184	7.2	55	121.3	25RF 408	25RF 508		

BFE reserves the right to change designs, dimensions or specifications without notice.

PRODUCT FEATURES:

- Outside Screw and Yoke (OS&Y).
- Self aligning two piece packing gland.
- Integral backseat.
- Integral body flanges.

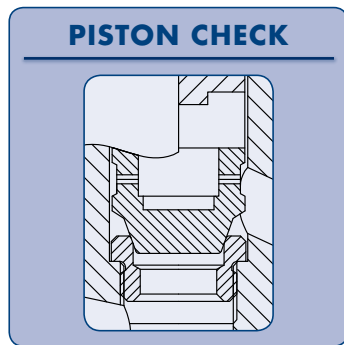

TRIM TYPE

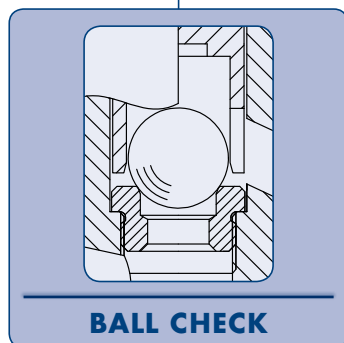

DESIGN TYPE S1 SPIRAL WOUND GASKET BODY-BONNET CONNECTION

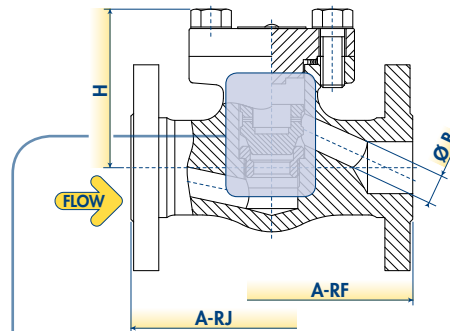

DESIGN TYPE S2 RING JOINT BODY-BONNET CONNECTION

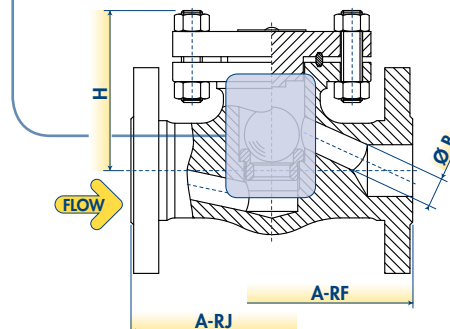

PISTON & BALL CHECK VALVES

WELDED BONNET PISTON & BALL CHECK VALVES BASIC CONFIGURATION THREADED AND SOCKET WELD ENDS



WORKING PRESSURE RATING	SIZE		STANDARD DESIGN TYPE	A		B		H		WEIGHT		FIGURE PISTON CHECK	FIGURE BALL CHECK		
	NPS	DN		mm	in	mm	in	mm	in	kg	lb				
ASME 800	1/2"	15	W1 / W3	80	3.15	9	0.35	54	2.13	0.9	2.0	WL 403	HWL 503	STANDARD BORE	
	3/4"	20	W1 / W3	90	3.54	13	0.51	60	2.36	1.1	2.4	WL 404	HWL 504		
	1"	25	W1 / W3	110	4.33	17	0.66	76	2.99	2.3	5.1	WL 405	HWL 505		
	1-1/2"	40	W1 / W3	150	5.91	29	1.14	92	3.62	5	11.0	WL 407	HWL 507		
	2"	50	W1 / W3	180	7.09	35	1.38	110	4.33	8.3	18.3	WL 408	HWL 508		
ASME 1500	1/2"	15	W1 / W3	90	3.54	9	0.35	54	2.13	1.4	3.1	9WL 403	9HWL 503		
	3/4"	20	W1 / W3	110	4.33	12	0.47	76	2.99	2.2	4.9	9WL 404	9HWL 504		
	1"	25	W1 / W3	127	5.00	15	0.59	86	3.39	3	6.6	9WL 405	9HWL 505		
	1-1/2"	40	W1 / W3	180	7.09	27	1.06	110	4.33	9.6	21.2	9WL 407	9HWL 507		
	2"	50	W1 / W3	210	8.27	32	1.26	150	5.91	16	35.3	9WL 408	9HWL 508		
ASME 800	1/4"	6	W1 / W3	80	3.15	7	0.28	55	2.17	1	2.2	W 401	HW 501		FULL BORE
	3/8"	10	W1 / W3	80	3.15	9	0.35	55	2.17	1	2.2	W 402	HW 502		
	1/2"	15	W1 / W3	90	3.54	13	0.51	60	2.36	1.2	2.6	W 403	HW 503		
	3/4"	20	W1 / W3	110	4.33	17	0.66	78	3.07	2.3	5.1	W 404	HW 504		
	1"	25	W1 / W3	127	5.00	22	0.86	88	3.46	3.3	7.3	W 405	HW 505		
	1-1/4"	32	W1 / W3	150	5.91	29	1.14	92	3.62	5.2	11.5	W 406	HW 506		
	1-1/2"	40	W1 / W3	180	7.09	35	1.38	110	4.33	8.7	19.2	W 407	HW 507		
2"	50	W1 / W3	210	8.27	45	1.77	150	5.91	14	30.9	W 408	HW 508			
ASME 1500	1/4"	6	W1 / W3	90	3.54	7	0.28	55	2.17	1.4	3.1	9W 401	9HW 501		
	3/8"	10	W1 / W3	90	3.54	9	0.35	55	2.17	1.4	3.1	9W 402	9HW 502		
	1/2"	15	W1 / W3	110	4.33	12	0.47	76	2.99	2.5	5.5	9W 403	9HW 503		
	3/4"	20	W1 / W3	127	5.00	15	0.59	84	3.31	3.7	8.2	9W 404	9HW 504		
	1"	25	W1 / W3	150	5.91	20	0.79	90	3.54	6	13.2	9W 405	9HW 505		
	1-1/4"	32	W1 / W3	180	7.09	27	1.06	110	4.33	10	22.0	9W 406	9HW 506		
	1-1/2"	40	W1 / W3	210	8.27	32	1.26	150	5.91	15.5	34.2	9W 407	9HW 507		
2"	50	W1 / W3	210	8.27	43	1.69	230	9.06	22	48.5	9W 408	9HW 508			
ASME 2500	1/4"	6	W2 / W3	90	3.54	7	0.28	70	2.76	3.2	7.1	25W 401	25HW 501		
	3/8"	10	W2 / W3	90	3.54	9	0.35	70	2.76	3.2	7.1	25W 402	25HW 502		
	1/2"	15	W2 / W3	110	4.33	11	0.43	86	3.39	3.8	8.4	25W 403	25HW 503		
	3/4"	20	W2 / W3	127	5.00	14.5	0.57	92	3.62	5.6	12.3	25W 404	25HW 504		
	1"	25	W2 / W3	180	7.09	19	0.75	110	4.33	10	22.0	25W 405	25HW 505		
ASME 4500	1-1/2"	40	W2 / W3	210	8.27	29	1.14	150	5.91	16	35.3	25W 407	25HW 507		
	2"	50	W2 / W3	230	9.06	38	1.50	180	7.09	21	46.3	25W 408	25HW 508		
	1/4"	6	W2 / W3	127	5.00	7	0.28	90	3.54	3.9	8.6	45W 401	45HW 501		
	3/8"	10	W2 / W3	127	5.00	7	0.28	90	3.54	3.9	8.6	45W 402	45HW 502		
	1/2"	15	W2 / W3	127	5.00	8	0.31	90	3.54	3.9	8.6	45W 403	45HW 503		
ASME 4500	3/4"	20	W2 / W3	180	7.09	11	0.43	110	4.33	10.5	23.1	45W 404	45HW 504		
	1"	25	W2 / W3	180	7.09	14	0.55	110	4.33	10.5	23.1	45W 405	45HW 505		
	1-1/2"	40	W2 / W3	230	9.06	25	0.98	180	7.09	25.2	55.6	45W 407	45HW 507		
	2"	50	W2 / W3	230	9.06	32	1.26	195	7.68	27	59.5	45W 408	45HW 508		

B/E reserves the right to change designs, dimensions or specifications without notice.

PRODUCT FEATURES:

- Outside Screw and Yoke (OS&Y).
- Self aligning two piece packing gland.
- Integral backseat.

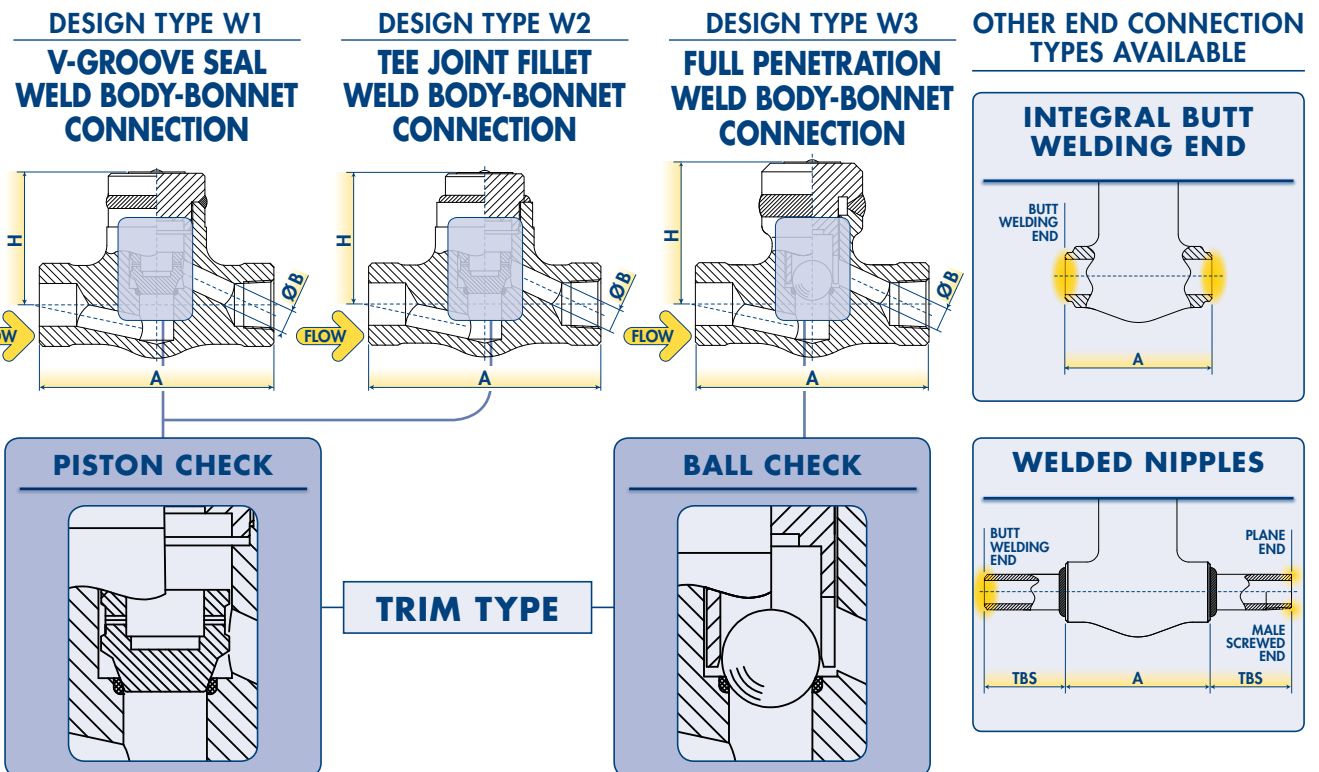

PISTON & BALL CHECK VALVES

WELDED BONNET PISTON & BALL CHECK VALVES BASIC CONFIGURATION ASME INTEGRAL FLANGED ENDS



WORKING PRESSURE RATING	SIZE		STANDARD DESIGN TYPE	A-RF		A-RJ		B		H		WEIGHT		FIGURE PISTON CHECK	FIGURE BALL CHECK	
	NPS	DN		mm	in	mm	in	mm	in	mm	in	kg	lb			
ASME 150	1/2"	15	W3	108	4.25	N.A.	N.A.	10	0.39	75	3.0	2.1	4.6	1HWL 403	1HWL 503	STANDARD BORE
	3/4"	20	W3	117.5	4.63	N.A.	N.A.	14	0.55	75	3.0	2.9	6.5	1HWL 404	1HWL 504	
	1"	25	W3	127	5.00	140	5.50	17	0.66	85	3.3	4.2	9.2	1HWL 405	1HWL 505	
	1-1/2"	40	W3	165	6.50	178	7.00	29	1.14	110	4.3	7.9	17.4	1HWL 407	1HWL 507	
	2"	50	W3	203	7.99	216	8.49	35	1.38	125	4.9	12.4	27.2	1HWL 408	1HWL 508	
ASME 300	1/2"	15	W3	152.5	6.00	163.5	6.44	9	0.35	75	3.0	3.1	6.9	3HWL 403	3HWL 503	
	3/4"	20	W3	178	7.01	190.5	7.51	13	0.51	80	3.1	4.9	10.9	3HWL 404	3HWL 504	
	1"	25	W3	203	7.99	216	8.49	17	0.66	88	3.5	7.0	15.5	3HWL 405	3HWL 505	
	1-1/2"	40	W3	229	9.02	241	9.52	29	1.14	115	4.5	12.8	28.3	3HWL 407	3HWL 507	
	2"	50	W3	267	10.51	282.5	11.13	35	1.38	130	5.1	18.1	39.8	3HWL 408	3HWL 508	
ASME 600	1/2"	15	W3	165	6.50	163.5	6.44	9	0.35	72	2.8	3.3	7.3	6HWL 403	6HWL 503	
	3/4"	20	W3	191	7.52	190.5	7.52	13	0.51	80	3.1	5.4	11.9	6HWL 404	6HWL 504	
	1"	25	W3	216	8.50	216	8.50	17	0.66	85	3.3	7.6	16.8	6HWL 405	6HWL 505	
	1-1/2"	40	W3	241	9.49	241	9.49	29	1.14	115	4.5	13.8	30.4	6HWL 407	6HWL 507	
	2"	50	W3	292	11.50	295	11.62	35	1.38	130	5.1	18.5	40.8	6HWL 408	6HWL 508	
ASME 1500	1/2"	15	W3	216	8.50	216	8.50	9	0.35	75	3.0	3.6	8.0	15HWLF 403	15HWLF 503	
	3/4"	20	W3	229	9.02	229	9.02	14	0.55	90	3.5	6.2	13.6	15HWLF 404	15HWLF 504	
	1"	25	W3	254	10.00	254	10.00	14	0.55	100	3.9	8.1	17.8	15HWLF 405	15HWLF 505	
	1-1/2"	40	W3	305	12.01	305	12.01	26	1.02	120	4.7	15.2	33.5	15HWLF 407	15HWLF 507	
	2"	50	W3	368	14.49	371.5	14.61	34	1.34	150	5.9	21.9	48.2	15HWLF 408	15HWLF 508	
ASME 150	1/2"	15	W3	108	4.25	N.A.	N.A.	13	0.51	75	3.0	2.7	5.9	1HW 403	1HW 503	FULL BORE
	3/4"	20	W3	117.5	4.63	N.A.	N.A.	17.5	0.69	85	3.3	3.4	7.5	1HW 404	1HW 504	
	1"	25	W3	127	5.00	140	5.50	22.5	0.89	100	3.9	4.9	10.9	1HW 405	1HW 505	
	1-1/2"	40	W3	165	6.50	178	7.00	35	1.38	125	4.9	9.5	20.9	1HW 407	1HW 507	
	2"	50	W3	203	7.99	216	8.49	45	1.77	140	5.5	15.2	33.5	1HW 408	1HW 508	
ASME 300	1/2"	15	W3	152.5	6.00	163.5	6.44	13	0.51	75	3.0	3.4	7.5	3HW 403	3HW 503	
	3/4"	20	W3	178	7.01	190.5	7.51	17.5	0.69	90	3.5	6.1	13.4	3HW 404	3HW 504	
	1"	25	W3	203	7.99	216	8.49	22.5	0.89	100	3.9	7.8	17.2	3HW 405	3HW 505	
	1-1/2"	40	W3	229	9.02	241	9.52	35	1.38	120	4.7	14.3	31.4	3HW 407	3HW 507	
	2"	50	W3	267	10.51	282.5	11.13	45	1.77	150	5.9	20.0	44.0	3HW 408	3HW 508	
ASME 600	1/2"	15	W3	165	6.50	163.5	6.44	13	0.51	75	3.0	3.6	8.0	6HW 403	6HW 503	
	3/4"	20	W3	191	7.52	190.5	7.52	17.5	0.69	90	3.5	6.2	13.6	6HW 404	6HW 504	
	1"	25	W3	216	8.50	216	8.50	22.5	0.89	100	3.9	8.1	17.8	6HW 405	6HW 505	
	1-1/2"	40	W3	241	9.49	241	9.49	35	1.38	120	4.7	15.2	33.5	6HW 407	6HW 507	
	2"	50	W3	292	11.50	295	11.62	45	1.77	150	5.9	21.9	48.2	6HW 408	6HW 508	
ASME 1500	1/2"	15	W3	216	8.50	216	8.50	12	0.47	105	4.1	7.1	15.7	15HWF 403	15HWF 503	
	3/4"	20	W3	229	9.02	229	9.02	14.5	0.57	125	4.9	10.6	23.5	15HWF 404	15HWF 504	
	1"	25	W3	254	10.00	254	10.00	19	0.75	135	5.3	13.8	30.4	15HWF 405	15HWF 505	
	1-1/2"	40	W3	305	12.01	305	12.01	31	1.22	155	6.1	25.2	55.5	15HWF 407	15HWF 507	
	2"	50	W3	368	14.49	371.5	14.61	38	1.50	195	7.7	47.5	104.7	15HWF 408	15HWF 508	
ASME 2500	1/2"	15	W3	264	10.39	264	10.39	11	0.43	128	5.0	13.6	29.9	25HWF 403	25HWF 503	
	3/4"	20	W3	273	10.75	273	10.75	14.5	0.57	130	5.1	15.2	33.5	25HWF 404	25HWF 504	
	1"	25	W3	308	12.13	308	12.13	19	0.75	152	6.0	25.0	55.1	25HWF 405	25HWF 505	
	1-1/2"	40	W3	384	15.12	387	15.24	28	1.10	188	7.4	51.3	113.1	25HWF 407	25HWF 507	
	2"	50	W3	451	17.76	454	17.88	38	1.50	190	7.5	53.2	117.3	25HWF 408	25HWF 508	

BFE reserves the right to change designs, dimensions or specifications without notice.

PRODUCT FEATURES:

- Outside Screw and Yoke (OS&Y).
- Self aligning two piece packing gland.
- Integral backseat.
- Integral body flanges.
- Bonnet Extension.

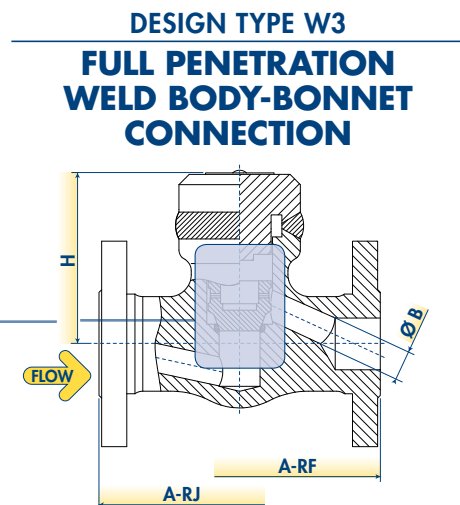
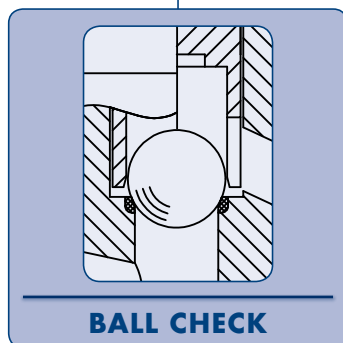
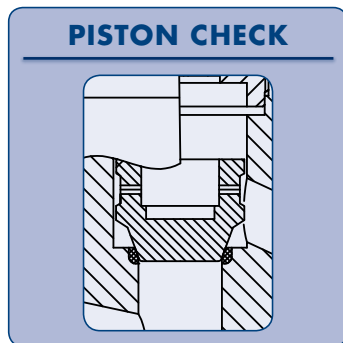

PISTON & BALL CHECK VALVES

AVAILABLE OPTIONS FOR PISTON & BALL CHECK VALVES OTHER VALVE OPTIONS OR CUSTOMISED VERSIONS ARE AVAILABLE ON REQUEST, CONTACT BFE FOR SPECIAL REQUIREMENTS.

■ SPRING ASSISTED CHECK VALVES

SPRING ASSISTED PISTON CHECK VALVE

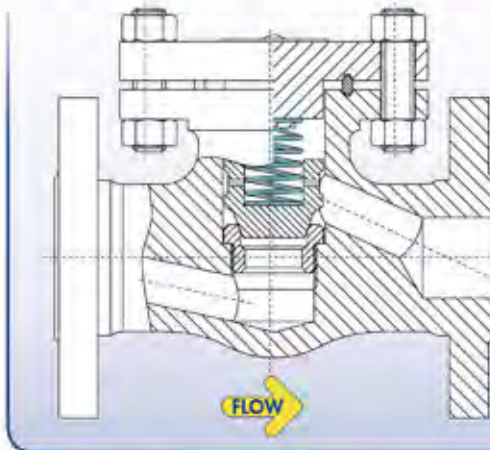

SPRING ASSISTED BALL CHECK VALVE

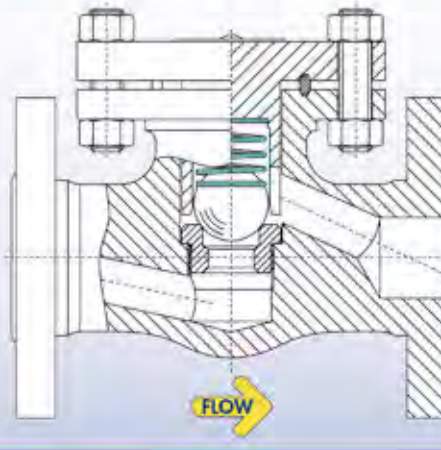

Standard valves have no spring and depend on the weight of the disc to start closure. These are called "horizontal check valves", as they will only function properly when installed in a horizontal line. Spring loaded check valves may be installed in any position, both in horizontal and vertical piping applications. The spring helps reduce noise, minimize the effect of pulsating flow and "water hammer" line shock and assists the closure member in seating faster.

■ SPECIAL END FINISH

The choice of end connections for connecting a valve to its associated pipe is performed by customers. Common end finish stated in the catalogue are socket, threaded, flanged (RF or RJ) and butt-weld ends. BFE is basically able to perform any end finish as per customer request, special end finish. Other end finish as follows: hub, compact flange, any ASME B16.5 end finish other than RF and RJ, etc.

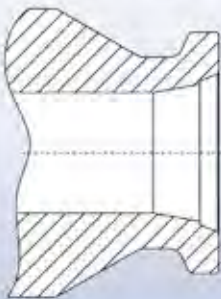

■ DISC AND TRIM TYPE FOR PISTON CHECK VALVES

BFE standard plug is the has a quick opening characteristic, this plug provides maximum flow with minimum pressure drop and is ideal when large flows are required just after opening. All BFE standard plugs require a flow direction F TO type. BFE trim variations can offer maximum versatility in flow control application within the capability of piston check valve design.

SOFT SEATED PLUG

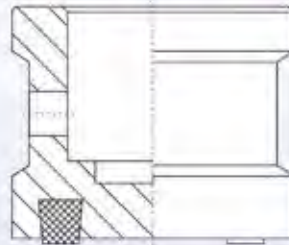

Soft seated trim provides improved seat tightness at low differential pressures. This design feature includes a plastic seating member on the valve closure element to supplement the basic metal-to-metal seating function. The design and material selection for these seating members are based on customer pressure, temperature and compatibility with the line fluid.

FLAT SEATED TRIM

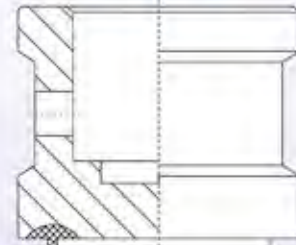

Metal to metal flat seated trim provides improved seat tightness with air/gas service. This design feature is required when additional or special test are required (e.g. API 598 air test or high pressure gas test).

■ CUSTOMIZED CRACKING PRESSURE

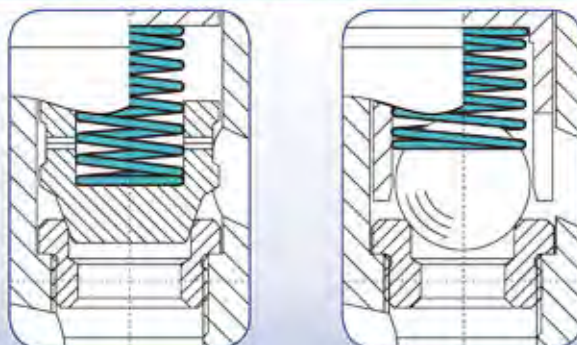

An important concept in check valves is the cracking pressure which is the minimum upstream pressure at which the valve will operate. Static cracking pressure is the minimum pressure at which fluid is by-passed through the valve at the rate of 0.1cc per minute during conditions of increasing pressure supplied by means of a hand pump. Valve cracking pressure can be customized to meet unique performance requirements through the modification of the trim design (closure member geometry, spring force and materials).

PISTON & BALL CHECK VALVES

AVAILABLE OPTIONS FOR PISTON & BALL CHECK VALVES OTHER VALVE OPTIONS OR CUSTOMISED VERSIONS ARE AVAILABLE ON REQUEST, CONTACT BFE FOR SPECIAL REQUIREMENTS.

IN-LINE VERTICAL CHECK VALVES

In-line check valves prevent reverse flow with disc movement that is parallel with the flow. With this design, the disc is always in the flow path. Closure member can be spring-loaded to assist in seating. The in-line check valve disc has very short disc travel and responds very quickly to flow stoppage or reversal, thus minimizing the potential for water hammer. The in-line check valve produces the most pressure drop when compared to other check valves of the same size.

IN-LINE BALL CHECK VALVE

VALVE SHOWN IN OPEN POSITION

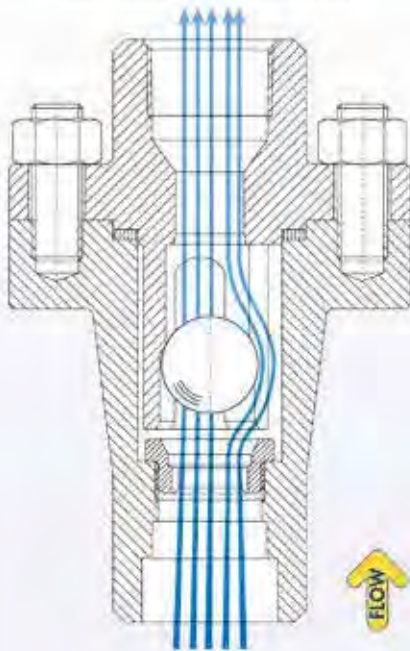

SPRING ASSISTED IN-LINE BALL CHECK VALVE

VALVE SHOWN IN CLOSED POSITION

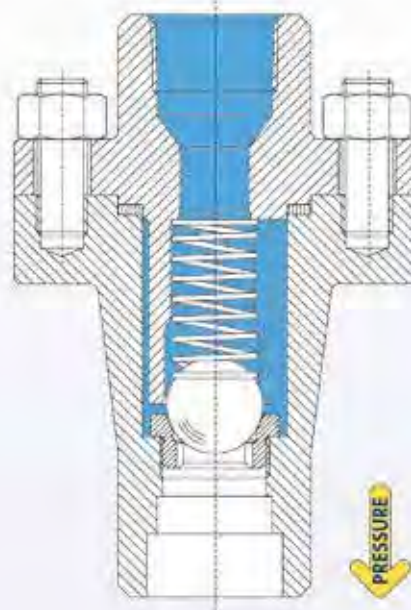

IN-LINE PISTON CHECK VALVE

VALVE SHOWN IN OPEN POSITION

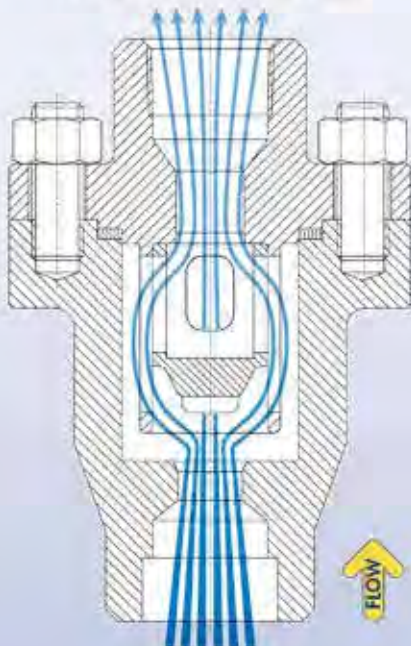

SPRING ASSISTED IN-LINE PISTON CHECK VALVE

VALVE SHOWN IN CLOSED POSITION

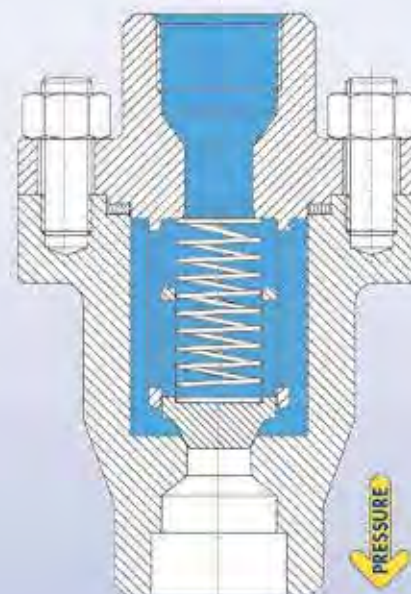

ALTERNATIVE DESIGN SOLUTIONS

There are a large variety of available valves and valve configurations for a wide variety of purposes and conditions not tabulated in this catalogue. Some example are listed below. Other valve designs or customised configurations are available on request, contact bfe for special requirements.

ANGLE PATTERN GLOBE VALVES

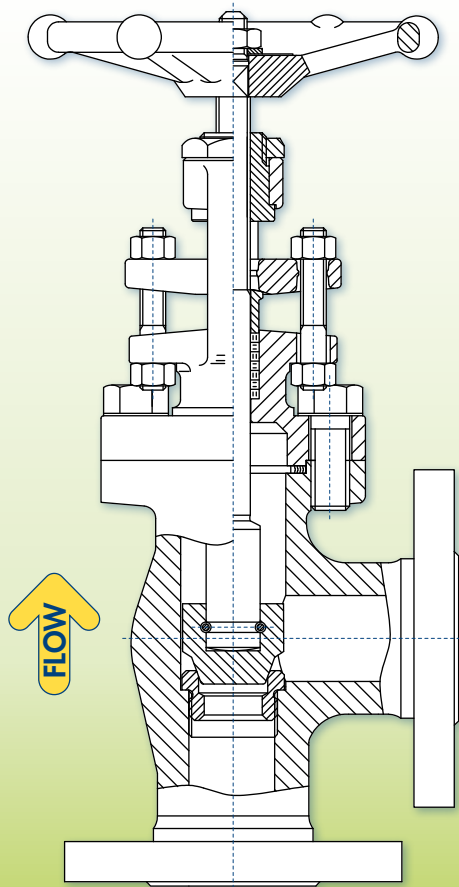

The Angle pattern globe valve is a modified version of "T"-Pattern Globe valve with inlet and outlet at right angles. When fitted at a change in piping direction, this valve eliminates a bend and has the advantage of smaller pressure drop than a conventional "T" pattern globe valve.

Angle valves have the same features of stem, disc and seat ring design as the globe valve.

The fundamental difference between the two is that the fluid flow through the angle valve makes a 90° turn.

These valves offer less resistance to flow than a globe valve with an elbow which it would replace. An angle valve reduces the number joints in a line, in addition to saving installation time.

They are also used in applications that have periods of pulsating flow because of their capability to handle the slugging effect of this type of flow.

BONNET LESS VALVES

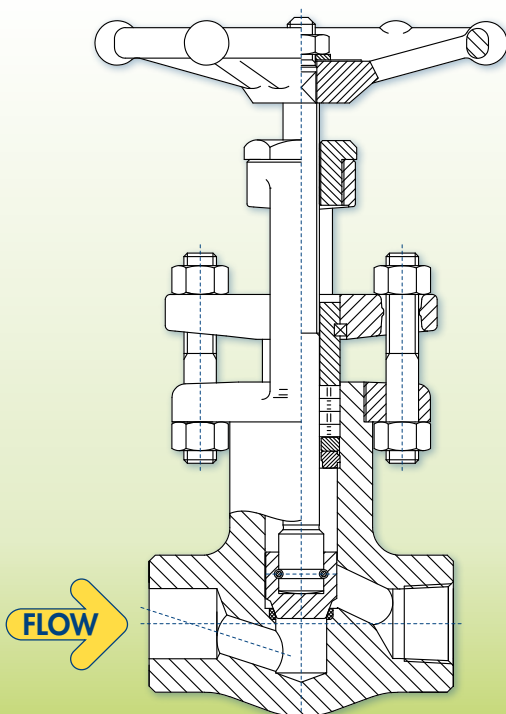

Bonnet less valves have no bonnet under pressure, the only pressure containing part of the valve is the body.

This feature removes the need for a separate bonnet and eliminates any gasket leakage, any bolted connection in case of bolted bonnet design and any welds in case welded bonnet designs.

Instead of the bonnet there is the yoke with structural functions only, this design allows in-line repair or inspection to be carried out more easily and at less cost than any other valve.

Stem, disc, and packing can be quickly removed and the seat fully exposed for "like new" restoration.

ALTERNATIVE DESIGN SOLUTIONS

ANGLE PATTERN PISTON & BALL CHECK VALVES

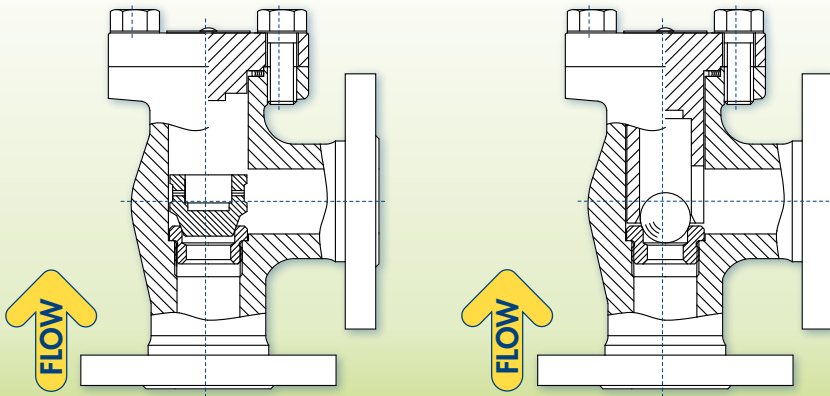

The Angle pattern check valve is a modified version of a standard check valve with inlet and outlet at right angles. When fitted at a change in piping direction, this valve eliminates a bend and has the advantage of smaller pressure drop than a conventional check valve. The fundamental difference between the two is that the fluid flow through the angle valve makes a 90° turn. These valves offer less resistance to flow than a standard check valve with an elbow which it would replace. An angle valve reduces the number joints in a line, in addition to saving installation time.

"Y" PATTERN PISTON & BALL CHECK VALVES

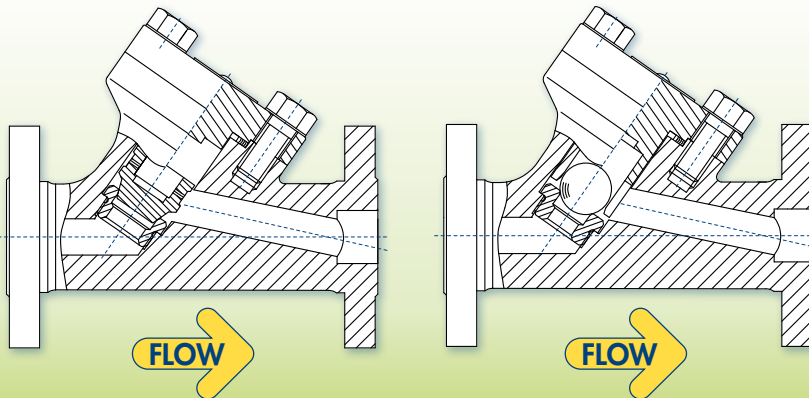

The "Y"-Pattern check valve is a modified version of a standard check valve. The body design selected will determine the pressure drop; inclined designs will provide the best flow performance. "Y"-Pattern check Valves are generally used to protect pumps or similar equipment, allowing the flow in only one direction and preventing flow reversal due to back pressure with the best possible effort for laminar flow and increased CV.

UNION BONNET VALVES

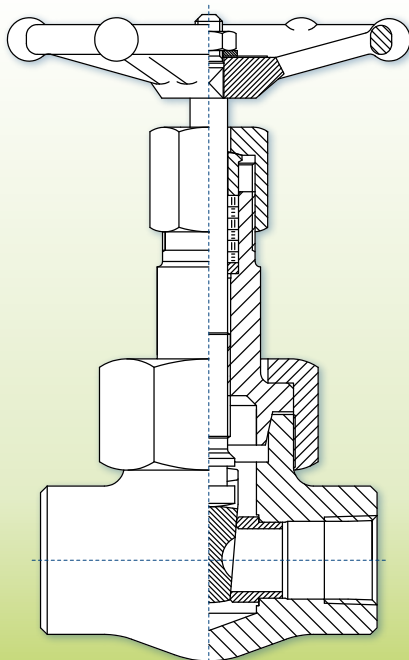

Union bonnet is the market standard design for bronze valves up to 2" size. A type of valve construction in which the bonnet is held on by a union nut with threads on the body. The nut is optimum sized hexagon shaped with high tensile properties to provide a leak-tight joint for maximum security under pressure. A union bonnet is appropriate for appliances that require regular inspection and maintenance and offers added reliability. Designed for rugged service applications, with maximum resistance to distortion produced by internal pressure.

Printed in Italy 1st edition.
Revision 02 2023/06/01

GENERAL SALE CONDITIONS

QUOTATION VALIDITY

Unless otherwise agreed, quotations are valid for four weeks from date of issue. The delivery terms are always "ex-works" unless otherwise stated. Prices and sale conditions can be changed without any previous notice.

ORDERS ACCEPTANCE

Orders are considered accepted at our general sale conditions clearly mentioned on order acknowledgment.

GOODS DELIVERY

The Company does not accept any responsibility for delays in delivery which are always intended as indicative and not binding. Transport risks are at receiver's charge also in case of CIF delivery.

GUARANTEE

The Company warrants all its products, from material and/or manufacturing defects, to be used as recommended by standards, and in accordance with approved piping practice and technique, for a period of one year from shipping date, unless otherwise agreed.

The Company liability covers eventual "free of charge" replacements for defective parts or products, providing it has not failed in the observance of above mentioned conditions and in use in compliance with standards, and, anyway, after return of defective goods. Any other liability, neither objective nor subjective will be accepted.

CLAIMS AND ORDER CANCELLATIONS

Claims will be considered only if made within 10 days from goods receipt. Partial or complete cancellations of order can be accepted only upon previous agreement or by written consent and, however, not later than 15 days from order date. Any controversy will be handled by the Court of Milan.

The material in this catalog is for general information. For specific performance data and proper product selection, consult BFE or your BFE representative. BFE reserves the right to change designs, dimensions or specifications without notice.





B.F.E. S.r.l. - Via Tonale, 70/A - 24061 Albano S.Alessandro (BG) Italy - Phone: 035.584111 - Fax: 035.583022 - Mail: sales@bfe.it
www.bfe.it

BONNEY FORGE



+001.814.542.2545
www.bonneyforge.com



+001.713.695.3633 - +001.713.695.3528 f
www.wfi-intl.com

RPC Valve

www.rpc-valve.com