

API 6A Valves



B.F.E. s.r.l.

BONNEY FORGE

BFE AVAILABLE CATALOGUES



Forged Valves



Cast Steel Valves

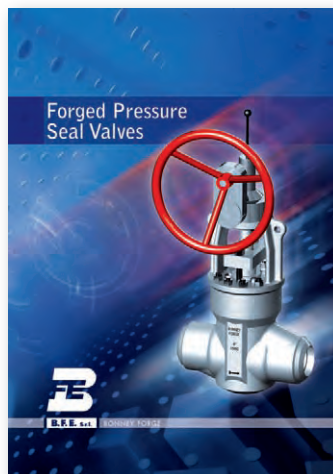

Forged Pressure Seal Valves



API 6A Valves

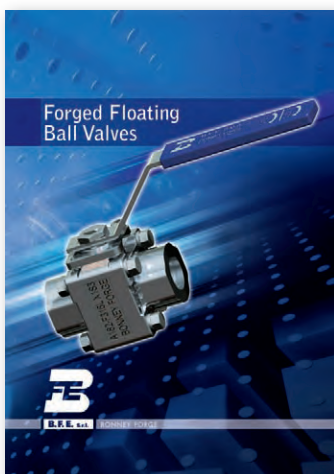

Forged Floating Ball Valves

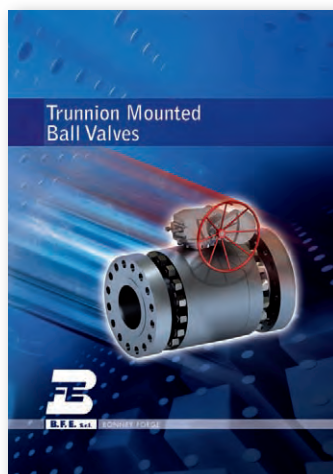

Trunnion Mounted Ball Valves

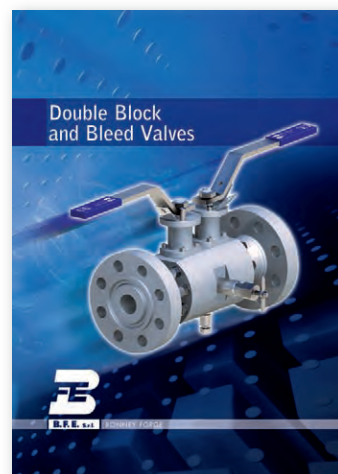

Double Block & Bleed Valves



Global quality. Total reliability. Two recurrent claims in present-day corporate strategies. But the transition from words to actions demands tangible measures. Specialization and organization underlie what amounts to a "quality culture" at BFE, not in the abstract but as a set of specific rules governing every stage of production. An operating model that is good to have in a partner who bears the responsibility of supplying valves that are essential to plant safety and regulation.

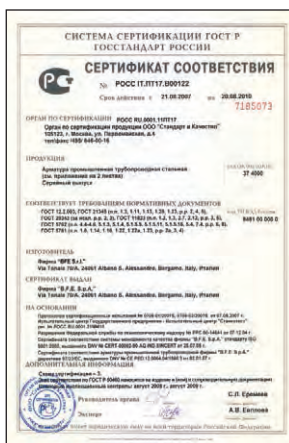

B.F.E. s.r.l.

DESIGN, CONSTRUCTION, MARKING FOR API 6A VALVES

BFE manufactures a complete line of quality API 6A valves, and can provide the exact valves and actuators to meet the most demanding application requirements.

Our API 6A valves are available in an extensive range of designs, materials, sizes and pressure classes and are in full conformance with API and NACE specifications.

All API 6A valves are designed in accordance with API 6A and where applicable with ASME VIII Div.1 and Div.

The BFE family of API 6A valves provides positive shut-off of fluids and gases under extreme service conditions.

BFE uses only high-quality materials inspected & tested to International Standards and utilizes advanced manufacturing technology with special emphasis on safety, quality, and long service life of our products, to ensure that our clients receive the "best in class" products available from us at a competitive price and delivered on time.

The forging material can ensure the best rigidity and strength under maximum rated operation pressure without inherent flaw of cast.

Other properties found in forging include greater impact resistance, resistance to fatigue cracking, particularly when cycling at either high or cryogenic temperature. Overdesigned wall thickness and adaptation of high strength tie bolts are convenient for valve maintenance and sufficient to bear the stress of pipe.

The internal parts of valve are carefully designed and selected to ensure reliability under all kinds of work conditions.

Since a variety of materials are available, BFE valves can be used with various fluids and gases including petroleum based oils and extreme sour gas service.

BFE API 6A Valve design is developed using the latest software based analysis tools.

At the design stage, all projects are analysed using 3D solid modeling tools.

Benefits include reduction of development time and costs, improved product quality, and ability to solve field problems for customers.

Product flexibility and accuracy is assured.

Finite Element Analysis (FEA) is a very important step of the development stage and ensures the best possible performance requirements. Valves operational problems, pressure/temperature related deformations and flow-related forces within a valve can be evaluated.

BFE S.r.l. uses the FEA for predicting failure due to unknown stresses by showing problem areas in a material and allowing designers to see all of the theoretical stresses within. This method of product design and testing is far superior to the manufacturing costs which would accrue if each sample was actually built and tested.

During any analysis project, it is the responsibility of the BFE analyst to verify that analysis results conform to the physics of the problem under study. Understanding the response of a structure or manufactured product allows effective design decisions to be made in developing structures and products that are functional, meet all engineering requirements, and can be manufactured and assembled.

Computational Fluid Dynamics (CFD) is used to simulate operating flow conditions. Evaluation of Valve CV coefficient and convective heat transfer coefficient takes place at the design stage.

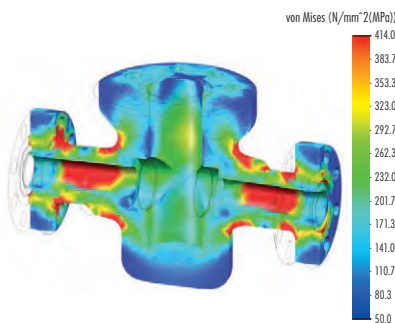

GENERAL MAIN FEATURES

WIDE RANGE

Size and pressure ranges that meet or exceed the requirements of API 6A, latest edition. Special range available on customer request and high temperature design acc.to API 6A Annex "G" available.

FIRE-SAFE TEST APPROVED

BFE API 6A valves are designed in accordance with API 607 & API SPEC 6FA where applicable.

FULL BORE

The full round bore design allows the fluid to flow through the valve smoothly without causing turbulence and minimize pressure drop. The absence of surface cavity eliminates the accumulation of foreign matter and allows passage of tools through the valves.

QUALITY LEVELS

Quality levels from PSL1 to PSL4 available.

WIDE RANGE OF TRIM OPTIONS

Valve trims for any service, including H₂S, CO₂, high-low temperature and extremely corrosive environments.

INSPECTION AND TESTING

Every valve is subjected on a routine basis to different non-destructive testing, like dye penetrant test on butt weld ends and on all hard faced and cladding areas.

Non-destructive tests are also carried out on the critical areas as defined by ASME B16.34. Optional examinations like:

- Radiographic
- Magnetic particles
- Ultrasonic
- Helium leak test

Personnel performing NDT are trained and qualified to EN 473/ASNT-SNT-TC-1A.





Every valve is subject to a pressure test in accordance with the standard API 6A.

The rated pressure for the applicable pressure class is in accordance with API 6A.

MARKING AND IDENTIFICATION

Each valve is identified on proper name plate and on valve body as required by API 6A, MSS-SP 25, ASME B16.34 Name plate carries all information on rating, size, valve body and trim material, customer tags. Body marking includes material designations (per ASTM) and heat code and of course the trade mark.

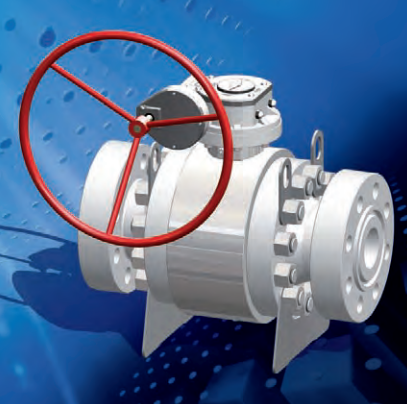
API 6A VALVE TYPES AND KEY FEATURES

SLAB GATE VALVE		<ol style="list-style-type: none"> 1. BFE slab-style gate is a simple one-piece & solid gate design, featuring metal to-metal seal between gate and seats, so as to apply to the most severe and demanding service condition, including corrosive and abrasive fluid environments. 2. Non-rising stem design to permit smart valve installation. 3. Full open through conduit construction to eliminate turbulence and pressure drop. 4. Upper grease injection fitting to reduce the abrasion between gate and seats. 5. Back seat with conical seal surface against stem allows stem seal replacement under pressure. 6. Expanding gate design available on request.
MUD SERVICE GATE VALVE		<ol style="list-style-type: none"> 1. Special Design made for high-pressure modern drilling mud systems. 2. In the case of dynamic pressure lifetime of the trim designed according to the most severe frequency & amplitude conditions at 7500psi series with modern triplex mud pumps. 3. Soft Seat maximal rating up to 7500psi. For API 10000 and above the applicable design is the slab type. 4. Typical internal fluid types are mud, cement, fracturing and water service. 5. High structural strength: All valves have the pressure retaining parts (Body and Bonnet) only in FORGED STEEL. 6. Self energized packing. The Packing doesn't require initial compression or periodical adjustments. 7. Quality level according to API 6A - PSL 1, 2 or 3.
TRUNNION BALL VALVE		<ol style="list-style-type: none"> 1. In the trunnion mounted design configuration, the ball is supported by bearing, held in position by the valve closures. This configuration allows to discharge any side loads on the valve body, enabling a smoother operation of the ball, minimizing the operating torque and reducing seat seal wear. 2. Anti-Blow Out stem design. 3. Standard seat design is single piston effect. Double piston effect sealing barrier available on request. 4. Antistatic device. 5. Modular double block and bleed valves (two ball and a needle system) according to API 6A are available on request.
SWING CHECK VALVE		<ol style="list-style-type: none"> 1. The closure element is a pivoted flapper which is swung open by flow and which sits against a mating flat surface in the valve body, under no-flow conditions. 2. Full bore and piggable design. 3. Metal to metal and bubble tight sealing. 4. Disc-Hinge center of mass designed as standard to allow horizontal or vertical installation. 5. Best CV values produces the lowest pressure drop. 6. Long service life. 7. Special seal surfaces design for gas service (PSL 3G & 4). 8. On Request external counterweights mounted on the hinge pin to increase or decrease the reaction time and speed of the disc returning to the closed position.

API 6A SLAB GATE VALVE

WORKING PRESSURE RATING	SIZE	OPERATOR	A [mm]	B [mm]	C [mm]	H [mm]	WEIGHT [Kg]	FIGURE
API 2000	2-1/16"	HANDWHEEL	295	52.4	400	500	90	2APITC 008
	2-9/16"	HANDWHEEL	333	65.1	490	525	110	2APITC 009
	3-1/8"	HANDWHEEL	359	79.4	490	550	140	2APITC 0011
	4-1/16"	HANDWHEEL	435	103.2	490	630	210	2APITC 0012
	5-1/8"	GEAR	562	130.2	600	700	420	2APITC 0013
	7-1/16"	GEAR	664	179.4	500	1000	830	2APITC 0015
API 3000	2-1/16"	HANDWHEEL	371	52.4	490	500	95	3APITC 008
	2-9/16"	HANDWHEEL	422	65.1	490	525	120	3APITC 009
	3-1/8"	HANDWHEEL	435	79.4	490	550	155	3APITC 0011
	4-1/16"	HANDWHEEL	511	103.2	600	630	230	3APITC 0012
	5-1/8"	GEAR	613	130.2	500	850	470	3APITC 0013
	7-1/16"	GEAR	714	179.4	600	1050	870	3APITC 0015
API 5000	2-1/16"	HANDWHEEL	371	52.4	490	500	95	5APITC 008
	2-9/16"	HANDWHEEL	422	65.1	490	525	120	5APITC 009
	3-1/8"	HANDWHEEL	473	79.4	490	550	160	5APITC 0011
	4-1/16"	HANDWHEEL	549	103.2	600	630	250	5APITC 0012
	5-1/8"	GEAR	727	130.2	500	850	500	5APITC 0013
	7-1/16"	GEAR	813	179.4	600	1050	950	5APITC 0015
API 10000	1-13/16"	HANDWHEEL	464	46	490	505	120	10APITC 007
	2-1/16"	HANDWHEEL	521	52.4	490	505	130	10APITC 008
	2-9/16"	HANDWHEEL	565	65.1	490	540	175	10APITC 009
	3-1/16"	HANDWHEEL	619	77.8	600	560	230	10APITC 0010
	4-1/16"	GEAR	670	103.2	500	800	440	10APITC 0012
	5-1/8"	GEAR	737	130.2	500	900	800	10APITC 0013
API 15000	7-1/16"	GEAR	889	179.4	600	1150	1300	10APITC 0015
	1-13/16"	HANDWHEEL	457	46	490	550	140	15APITC 007
	2-1/16"	HANDWHEEL	483	52.4	490	560	150	15APITC 008
	2-9/16"	HANDWHEEL	533	65.1	600	580	260	15APITC 009
	3-1/16"	GEAR	598	77.8	500	700	430	15APITC 0010
	4-1/16"	GEAR	737	103.2	500	940	750	15APITC 0012
5-1/8"	GEAR	889	130.2	600	1050	1400	15APITC 0013	

HANDWHEEL OPERATED VALVE

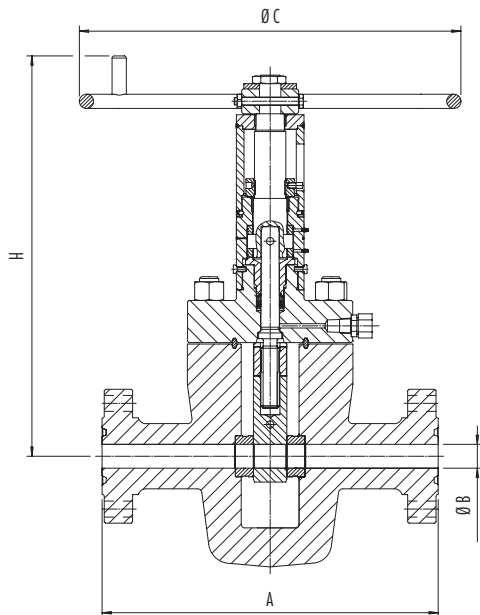

GEAR OPERATED VALVE

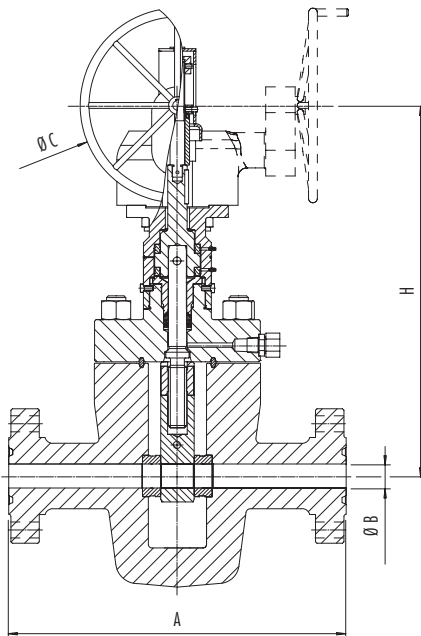

API 6A MUD SERVICE GATE VALVE

WORKING PRESSURE RATING	SIZE	OPERATOR	A [mm]	B [mm]	C [mm]	H [mm]	WEIGHT [Kg]	FIGURE
API 2000	2-1/16"	HANDWHEEL	295	52.4	400	500	80	2MD 008
	2-9/16"	HANDWHEEL	333	65.1	490	525	90	2MD 009
	3-1/8"	HANDWHEEL	359	79.4	490	550	120	2MD 0011
	4-1/16"	HANDWHEEL	435	103.2	490	630	180	2MD 0012
	5-1/8"	GEAR	562	130.2	600	700	350	2MD 0013
	7-1/16"	GEAR	664	179.4	500	1000	700	2MD 0015
API 3000	2-1/16"	HANDWHEEL	371	52.4	490	500	80	3MD 008
	2-9/16"	HANDWHEEL	422	65.1	490	525	100	3MD 009
	3-1/8"	HANDWHEEL	435	79.4	490	550	130	3MD 0011
	4-1/16"	HANDWHEEL	511	103.2	600	630	190	3MD 0012
	5-1/8"	GEAR	613	130.2	500	850	400	3MD 0013
	7-1/16"	GEAR	714	179.4	600	1050	730	3MD 0015
API 5000	2-1/16"	HANDWHEEL	371	52.4	490	500	80	5MD 008
	2-9/16"	HANDWHEEL	422	65.1	490	525	100	5MD 009
	3-1/8"	HANDWHEEL	473	79.4	490	550	135	5MD 0011
	4-1/16"	HANDWHEEL	549	103.2	600	630	210	5MD 0012
	5-1/8"	GEAR	727	130.2	500	850	420	5MD 0013
	7-1/16"	GEAR	813	179.4	600	1050	800	5MD 0015
API 7500 (SEE NOTE AM1)	1-13/16"	HANDWHEEL	464	46	490	505	100	75MD 007
	2-1/16"	HANDWHEEL	521	52.4	490	505	110	75MD 008
	2-9/16"	HANDWHEEL	565	65.1	490	540	150	75MD 009
	3-1/16"	HANDWHEEL	619	77.8	600	560	200	75MD 0010
	4-1/16"	GEAR	670	103.2	500	800	380	75MD 0012
	5-1/8"	GEAR	737	130.2	500	900	680	75MD 0013
	7-1/16"	GEAR	889	179.4	600	1150	1105	75MD 0015

NOTE AM1: Face-to-Face, valve bore & flange dimensions according to API 10000.

HANDWHEEL OPERATED VALVE

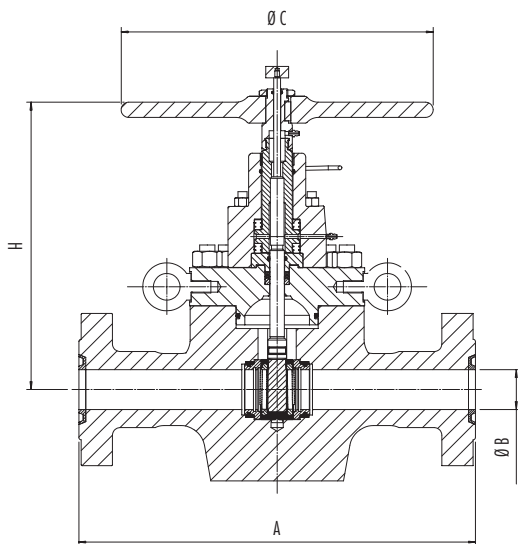

GEAR OPERATED VALVE

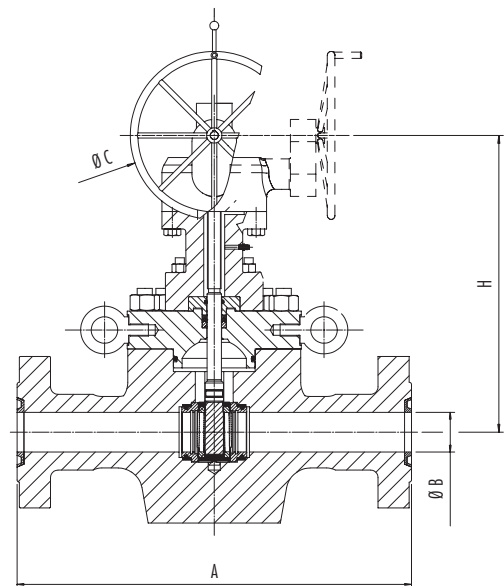

API 6A TRUNNION MOUNTED BALL VALVE

WORKING PRESSURE RATING	SIZE	OPERATOR	A [mm]	B [mm]	C [mm]	H [mm]	WEIGHT [Kg]	FIGURE
API 2000	2-1/16"	GEAR	295	52.4	215	300	60	A2 808
	2-9/16"	GEAR	333	65.1	230	300	80	A2 809
	3-1/8"	GEAR	359	79.4	250	300	100	A2 811
	4-1/16"	GEAR	435	103.2	280	400	210	A2 812
	5-1/8"	GEAR	562	130.2	320	600	360	A2 813
	7-1/16"	GEAR	664	179.4	360	600	480	A2 815
API 3000	2-1/16"	GEAR	371	52.4	215	300	80	A3 808
	2-9/16"	GEAR	422	65.1	230	400	105	A3 809
	3-1/8"	GEAR	435	79.4	250	400	130	A3 811
	4-1/16"	GEAR	511	103.2	280	600	250	A3 812
	5-1/8"	GEAR	613	130.2	340	800	430	A3 813
	7-1/16"	GEAR	714	179.4	400	800	600	A3 815
API 5000	2-1/16"	GEAR	371	52.4	225	400	120	A5 808
	2-9/16"	GEAR	422	65.1	240	400	160	A5 809
	3-1/8"	GEAR	473	79.4	265	600	220	A5 811
	4-1/16"	GEAR	549	103.2	290	600	350	A5 812
	5-1/8"	GEAR	727	130.2	350	800	570	A5 813
	7-1/16"	GEAR	813	179.4	440	800	800	A5 815
API 10000	1-13/16"	GEAR	464	46	260	600	145	A10 807
	2-1/16"	GEAR	521	52.4	280	600	190	A10 808
	2-9/16"	GEAR	565	65.1	310	600	300	A10 809
	3-1/16"	GEAR	619	77.8	330	800	390	A10 810
	4-1/16"	GEAR	670	103.2	380	800	510	A10 812
	5-1/8"	GEAR	737	130.2	440	800	800	A10 813
	7-1/16"	GEAR	889	179.4	490	800	1400	A10 815

GEAR OPERATED VALVE

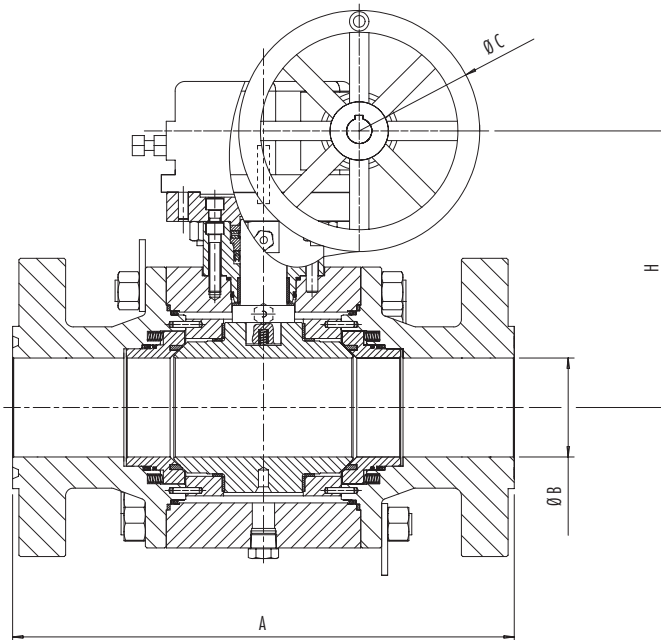

API 6A SWING CHECK VALVE

WORKING PRESSURE RATING	SIZE	A [mm]	B [mm]	H [mm]	WEIGHT [Kg]	FIGURE
API 2000	2-1/16"	295	52,5	160	55	2APITC 608
	2-9/16"	333	62,7	175	70	2APITC 609
	3-1/8"	359	77,9	190	90	2APITC 611
	4-1/16"	435	102,3	230	150	2APITC 612
	7-1/16"	562	146,3	310	330	2APITC 615
API 3000	2-1/16"	371	49,3	180	65	3APITC 008
	2-9/16"	422	59	200	95	3APITC 009
	3-1/8"	384	73,7	215	110	3APITC 0011
	4-1/16"	460	97,2	270	225	3APITC 0012
API 5000	2-1/16"	371	42,9	190	75	5APITC 008
	2-9/16"	422	54	210	115	5APITC 009
	3-1/8"	473	66,6	230	130	5APITC 0011
	4-1/16"	549	87,3	300	300	5APITC 0012
	7-1/16"	711	131,8	335	560	5APITC 0015
API 10000	1-13/16"	464	46	255	98	10APITC 007
	2-1/16"	521	52,4	280	130	10APITC 008
	2-9/16"	565	65,1	297	175	10APITC 009
	3-1/16"	619	77,8	290	207	10APITC 0010
	4-1/16"	670	103,2	350	450	10APITC 0012
	5-1/8"	737	130,2	400	600	10APITC 0013
	7-1/16"	889	179,4	550	940	10APITC 0015

SWING CHECK VALVE

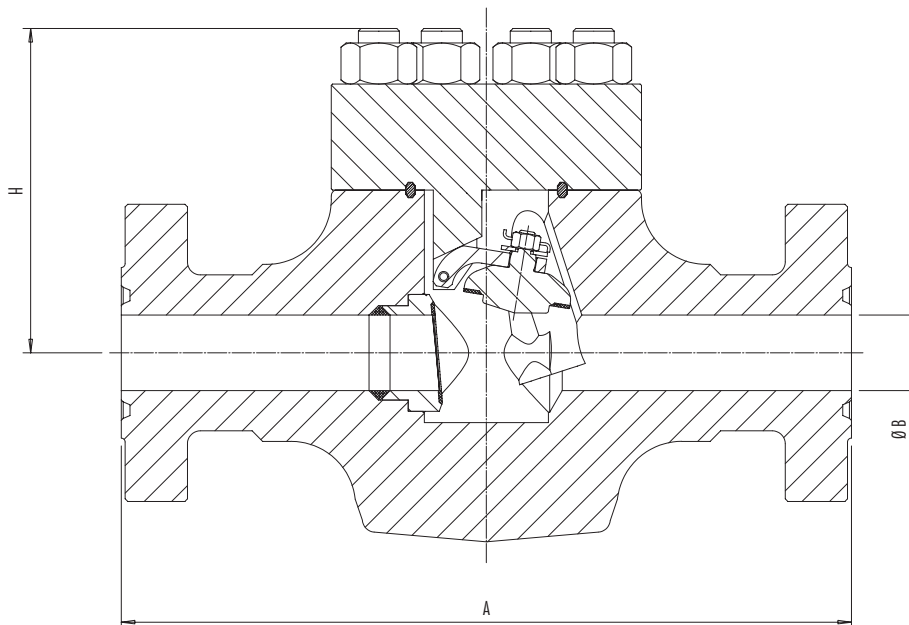

GENERAL SALE CONDITIONS

QUOTATION VALIDITY

Unless otherwise agreed, quotations are valid for four weeks from date of issue.

The delivery terms are always “ex-works” unless otherwise stated.

Prices and sale conditions can be changed without any previous notice.

ORDERS ACCEPTANCE

Orders are considered accepted at our general sale conditions clearly mentioned on order acknowledgment.

GOODS DELIVERY

The Company does not accept any responsibility for delays in delivery which are always intended as indicative and not binding. Transport risks are at receiver’s charge also in case of CIF delivery.

GUARANTEE

The Company warrants all its products, from material and/or manufacturing defects, to be used as recommended by standards, and in accordance with approved piping practice and technique, for a period of one year from shipping date, unless otherwise agreed.

The Company liability covers eventual “free of charge” replacements for defective parts or products, providing it has not failed in the observance of above mentioned conditions and in use in compliance with standards, and, anyway, after return of defective goods. Any other liability, neither objective nor subjective will be accepted.

CLAIMS AND ORDER CANCELLATIONS

Claims will be considered only if made within 10 days from goods receipt.

Partial or complete cancellations of order can be accepted only upon previous agreement or by written consent and, however, not later than 15 days from order date.

Any controversy will be handled by the Court of Milan.



Printed in Italy 2013w 2nd edition

**Dimensions on the catalogue are indicative.
B.F.E. S.r.l. reserves the right to make all necessary changes without notice.**



B.F.E. S.r.l. - Via Tonale, 70/A - 24061 Albano S.Alessandro (BG) Italy - Phone: 035.584111 - Fax: 035.583022 - Mail: sales@bfe.it
www.bfe.it

BONNEY FORGE



BONNEY FORGE
+001.814.542.2545
www.bonneyforge.com



+001.713.695.3633 - +001.713.695.3528 f
www.wfi-intl.com

RPC Valve

www.rpc-valve.com