

Double Block and Bleed Valves

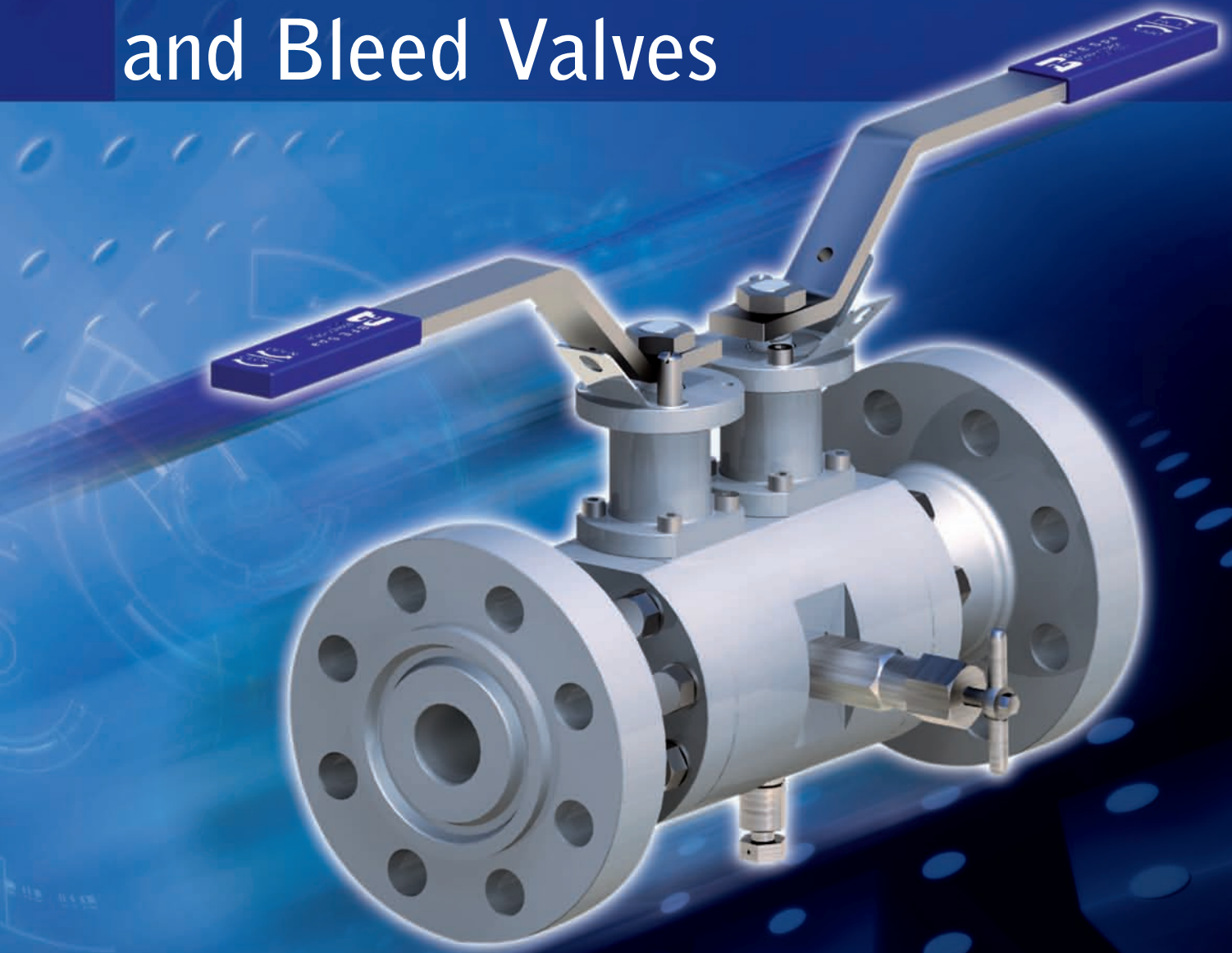

B.F.E. s.r.l.

BONNEY FORGE

BFE AVAILABLE CATALOGUES



Forged Valves



Cast Steel Valves

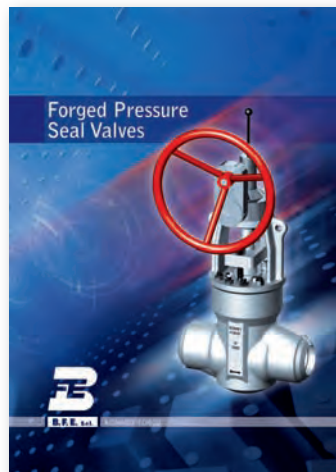

Forged Pressure Seal Valves

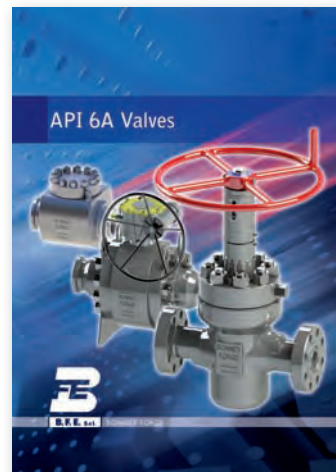

API 6A Valves

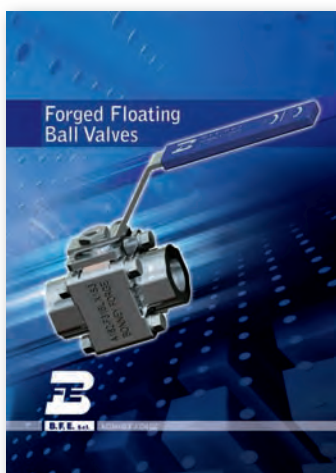

Forged Floating Ball Valves

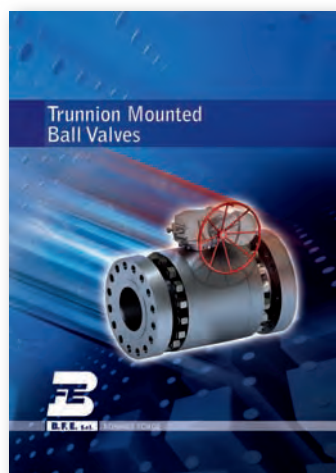

Trunnion Mounted Ball Valves

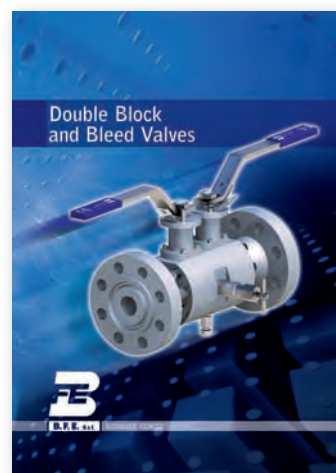

Double Block & Bleed Valves



Global quality. Total reliability. Two recurrent claims in present-day corporate strategies. But the transition from words to actions demands tangible measures. Specialization and organization underlie what amounts to a "quality culture" at BFE, not in the abstract but as a set of specific rules governing every stage of production. An operating model that is good to have in a partner who bears the responsibility of supplying valves that are essential to plant safety and regulation.

B. F. E. s.r.l.

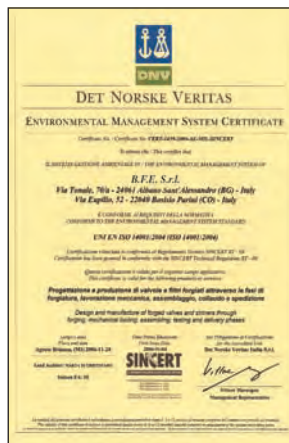

DESIGN, CONSTRUCTION, MARKING FOR DOUBLE BLOCK & BLEED VALVES

PRODUCT OVERVIEW

BFE manufactures the most complete line of quality Double Block & Bleed valves, and can provide the exact Double Block & Bleed valves and actuators to meet the most demanding application requirements.

Our Double Block & Bleed valves are available in an extensive range of designs, materials, sizes and pressure classes and are in full conformance with ASME, API and NACE specifications.

All Double Block & Bleed valves are designed in accordance with ASME B16.34 and where applicable with API 6D or BS EN ISO 17292.

The BFE family of Double Block & Bleed valves provides positive shut-off of fluids and gases under extreme service conditions.

BFE uses only high-quality materials inspected & tested to International Standards and utilizes advanced manufacturing technology with special emphasis on safety, quality, and long service life of our products, to ensure that our clients receive the "best in class" products available from us at a competitive price and delivered on time.

The forging material can ensure the best rigidity and strength under maximum rated operation pressure without inherent flaw of cast.

Other properties found in forging include greater impact resistance, resistance to fatigue cracking, particularly when cycling at either high or cryogenic temperature. Overdesigned wall thickness and adaptation of high strength tie bolts are convenient for valve maintenance and sufficient to bear the stress of pipe.

The internal parts of valve are carefully designed and selected to ensure reliability under all kinds of work conditions.

Since a variety of materials are available, BFE valves can be used with various fluids and gases including petroleum based oils and some water glycols.

BFE Double Block & Bleed Valve design is developed using the latest software based analysis tools.

At the design stage, all projects are analysed using 3D solid modeling tools.

Benefits include reduction of development time and costs, improved product quality, and ability to solve field problems for customers. Product flexibility and accuracy is assured.

Finite Element Analysis (FEA) is a very important step of the development stage and ensures the best possible performance requirements. Valves operational problems, pressure/temperature related deformations and flow-related forces within a valve can be evaluated.

BFE uses the FEA for predicting failure due to unknown stresses by showing problem areas in a material and allowing designers to see all of the theoretical stresses within. This method of product design and testing is far superior to the manufacturing costs which would accrue if each sample was actually built and tested.

During any analysis project, it is the responsibility of the BFE analyst to verify that analysis results conform to the physics of the problem under study. Understanding the response of a structure or manufactured product allows effective design decisions to be made in developing structures and products that are functional, meet all engineering requirements, and can be manufactured and assembled.

Computational Fluid Dynamics (CFD) is used to simulate operating flow conditions. Evaluation of Valve CV coefficient and convective heat transfer coefficient takes place at the design stage.

MAIN FEATURES

FIRE-SAFE TEST APPROVED

BFE Double Block & Bleed valves are designed in accordance with API 607 & API SPEC 6FA.

DOUBLE BODY GASKET

All BFE Double Block & Bleed valves are equipped with two body gasket. The first body gasket is in soft material and the second in graphite (if not otherwise required), this combination assures the best seal characteristic in whatever corrosive service as well as giving a fire safe design.

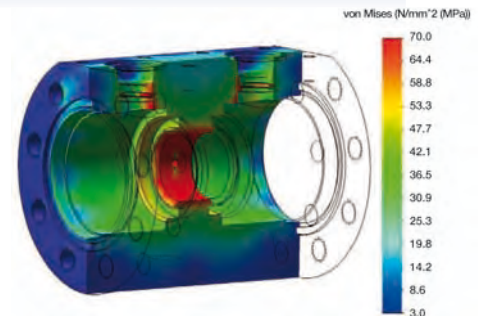

ANTI-STATIC DEVICE

In order to prevent static electricity which may light the fluid, static-conduction spring is set between the stem and the ball.

ANTI BLOW-OUT PROOF STEM

The stem is designed with integral T-Type shoulder to provide blow-out proof effectively. The design assures that the stem can not be blown out of the valve in the case of the packing being removed while the valve is under pressure.

CONTROLLED STEM & STUFFING BOX FINISH

Stem and stuffing box finish machining is a key point of control. The stem is made by cold rolling and stem surface finish is controlled by $Ra=0.4$, which can reduce friction of stem movement and ensure the seal. The stuffing box surface is controlled within $Ra=1.6$ for better sealing performance.

SOLID BALL

The solid ball used by BFE provides straight-through flow and real full-port performance characteristics. Hollow ball or cored cavity ball are not used for BFE products.

LONGEVITY OF LIFE

Special consideration was devoted to the attainment of enhanced life and operation of our valve throughout design, development, testing and manufacturing stages.

Valve designs combined with the selection of advanced materials are such that long periods of inactivity should not affect the operations of efficiency.

LOW TORQUE OUTPUT

Seat designs, stem-bearing system and stem seal arrangements ensure consistent minimal torque values.

FLOW CAPACITY

Valve design allows for high flow capacity in liquid or gas services regardless of whether the media is clean or dirty. Full port valves allow for pigging and ensure maximum flow capacity.

FIELD REPAIRABLE

Simple user friendly design allows for quick and easy part replacement requiring minimal "Down Time".

ISO FLANGE INTEGRATED IN THE BODY DESIGN

ISO 5211 mounting always integrated in the valve as standard design.

LOCKING DEVICE

Locking device is supplied as standard in order to prevent unauthorized opening/closing.

BFE locking device can lock the valve in either the open or closed position and cannot be breached by removing the lever.

INSPECTION AND TESTING

Every valve is subjected on routine basis to different non-destructive testing, like dye penetrant test on butt weld ends and on all hard faced and cladding areas.

Non-destructive test are also carried out on the critical areas as defined by ASME B16.34. Optional examinations like:

Radiographic
Magnetic particles
Ultrasonic
Helium leak test

Personal performing NDT are trained and qualified to EN 473/ ASNT-SNT-TC-1A.

Every valve is subject to a pressure test in accordance with the standard API 598 or BS 6755 Part-1.

The rated pressure for the applicable pressure class is in accordance with ASME B16.34 / EN 12516-1/2.

MARKING AND IDENTIFICATION

Each valve is identified on proper name plate and on valve body as required by MSS-SP 25, ASME B16.34 Name plate carries all information on rating, size, valve body and trim material, customer tags.

On body, marking includes material designations (per ASTM) and heat code and of course the trade mark.

DOUBLE BLOCK & BLEED - FLOATING TYPE

The design of BFE ball valves is based on the "floating ball" principle which allows the ball to turn freely between the ball seals.

A positive seal is attained by fluid pressure acting on the upstream surface of the ball and

producing a constant uniform contact between the downstream ball seal and the ball.

The ball is operated by a sealed spindle with a projecting square end to which the control handle or optional actuator is attached.

Ball valves are intended to be used as on/off flow control devices and are not to be used to throttle fluid flow. The valves should always be either fully open or fully closed.

DOUBLE BLOCK & BLEED - TRUNNION TYPE

Trunnion ball valve have a mechanical means of anchoring the ball at the top and the bottom, this design is the standard design applied on larger and higher pressure valves.

Sealing is achieved by spring loaded piston

type seats which shut off flow when line pressure acts on the upstream seat. Automatic relief of cavity overpressure is assured due to the trunnion design in case of self relieving seats (BFE standard design). The ball is oper-

ated by a sealed spindle to which the operator is attached. Ball valves are intended to be used as on/off flow control devices and are not to be used to throttle fluid flow. The valves should always be either fully open or closed.

PISTON EFFECT PRINCIPLE

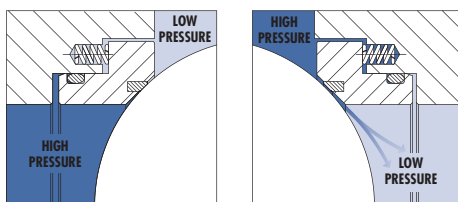

SELF RELIEVING SEAT

In the standard design of Trunnion Mounted Ball Valves, each seat ring performs the "Single Piston" action. In this case the pressure acting on the external side of the seat ring pushes the same against the ball while the pressure acting on the internal side of the seat rings pushes the same away from the ball. Therefore, while both seat-rings grant the required tightness, when the pressure is applied on their external side, they are defined "Self Relieving", allowing any over pressure acting in the body cavity to be discharged in the line as soon as the force caused by the pressure overcomes the one provided by the springs.

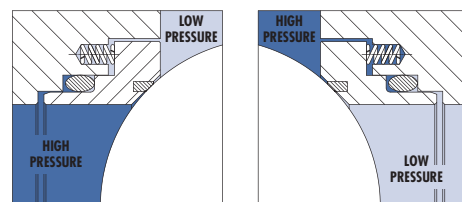

DOUBLE PISTON EFFECT OPTION

On request the seat rings design may be modified to perform the "Double Piston Effect" action. In this case the pressure acting on both the external and internal side of the seat rings, results in a force pushing the same against the ball, therefore each seat ring grants the required tightness even if the pressure is applied in the body cavity.

This features assures dead-tight sealing simultaneously on both sides of the ball and in order to release any possible over pressure developed into the body cavity it is necessary to use an external safety relief valve.

WHY USE A BFE DOUBLE BLOCK AND BLEED VALVE?

BFE Double Block and Bleed Valves replace existing traditional techniques employed by pipeline engineers to generate a double block and bleed configuration in the pipeline.

Conventionally, in order to achieve a double block and bleed system, engineers would install two standard isolation valves and a separate facility for bleeding the cavity in between. Space is usually at a premium in the refinery environment, and this approach — requiring an additional valve unit to be installed as well as a “T”-junction to allow the cavity to be bled — more than doubles the space required compared with a single valve system. This increase in size can often make the installation unfeasible, especially where multiple valves along the line are to be upgraded.

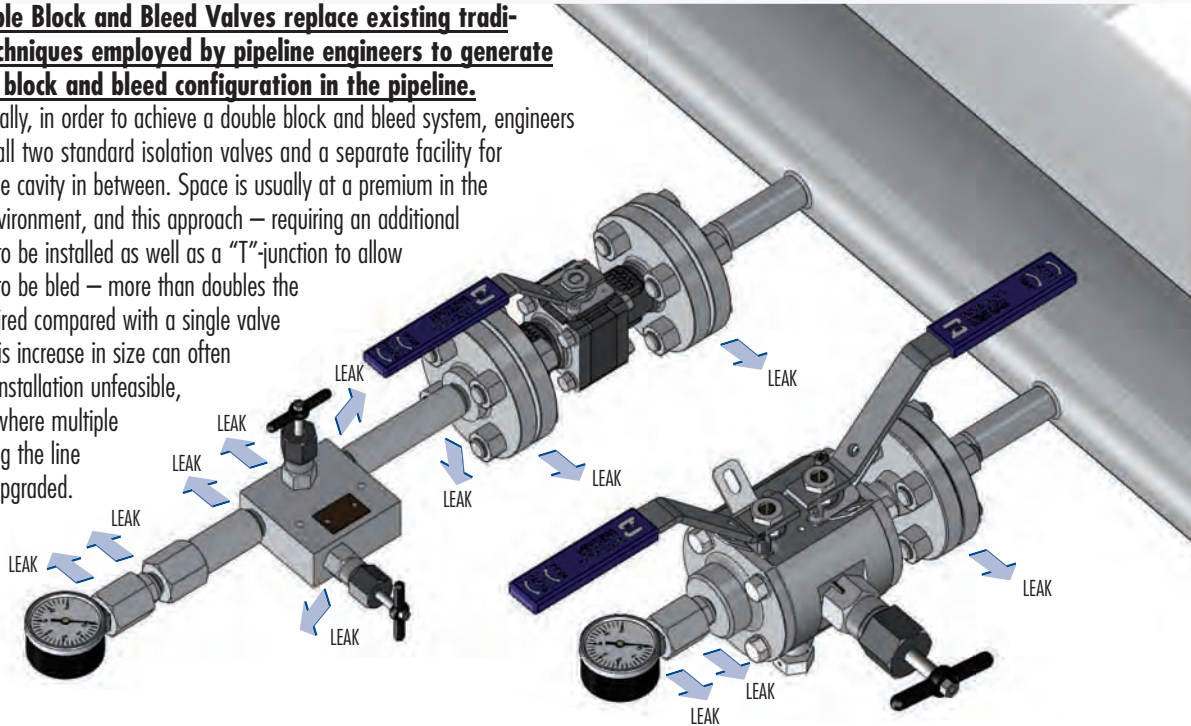

BFE Double Block and Bleed Valves provide the reduction of potential leak points.

Tackling fugitive emissions is high on the agenda for valve end user. The problems presented by these emissions are multiple — not only does losing valuable media through leaks carry an economic cost, but the emissions are also a significant contributor to air pollution and climate change. As well as this, emissions of volatile compounds can lead to long term health risks for employees and local communities, and escaping flammable substances can increase the risk of explosions. While the volume of medium escaping from any given leak may be very small, the cumulative effect across a large facility can add up to a significant proportion of the plant’s total emissions. Any seal between two separate pieces of material represents a potential leak path and therefore increasing the number of different sections of pipe required for a valve installation significantly increases the likelihood of media escaping from the system.

BFE Double Block and Bleed Valves improve safety.

Incorporating the three valves into a single housing increases the safety of the system by removing connections between separate units, resulting in fewer potential leak paths.

The unit incorporates two separate ball valves, delivering 100 per cent tight shutoff using either plastic soft seats or heavy duty metal-to-metal seats coated with a tungsten or chrome carbide-based coating. The volume of the cavity between the valves is also significantly reduced, allowing operators to evacuate the space and establish a safe isolation more quickly — a major benefit in emergency scenarios. The reduction in volume of the material removed from the valve also means less waste, reduced handling, lower costs and easier disposal.

BENEFITS OF THE BFE DESIGN FOR DOUBLE BLOCK AND BLEED VALVES

- | | |
|---|---|
| <ul style="list-style-type: none"> • IMPROVED SAFETY IN OPERATIONS | <ul style="list-style-type: none"> • COMPACT DESIGN |
| <ul style="list-style-type: none"> • SPACE, WEIGHT, AND COST SAVINGS | <ul style="list-style-type: none"> • UNINTERRUPTED FLOW FOR NEGLIGIBLE PRESSURE DROP |
| <ul style="list-style-type: none"> • REDUCED LEAKAGE POINTS | <ul style="list-style-type: none"> • REDUCED STRESSES FROM LOADING AND VIBRATION |
| <ul style="list-style-type: none"> • REDUCED INSTALLATION AND MAINTENANCE REQUIREMENTS AND COSTS | <ul style="list-style-type: none"> • DESIGNED AND ENGINEERED ON A CASE-BY-CASE BASIS |

DOUBLE BLOCK AND BLEED CONCEPT

The increased activity in the offshore sector of the energy industry has led to additional factors that have to be taken into consideration when designing piping systems. Space in these modern locations is always at a premium and the design of piping systems and their associated components must therefore be more compact. There are structural constraints that are also very important, such as keeping the structure as light as possible, and there are obvious benefits from making components smaller and lighter. Construction site job is also very expensive and any reduction in installation manpower is also beneficial. The above situation has led to the modification of the patterns of valve components to incorporate savings in space, weight, and labor costs where possible, while still retaining the original function of the valve.

The greatest savings are to be seen in the reduction of leak to atmosphere because the potential leak points are minimized compared to the conventional design.

Process isolation philosophy has become more complex as safety issues have to be addressed and the requirement for double block and bleed isolation has become more commonly used. Double Block and Bleed isolation requires two in-line isolation valves and a bleed valve, used to drain or vent trapped fluid between the two closure elements.

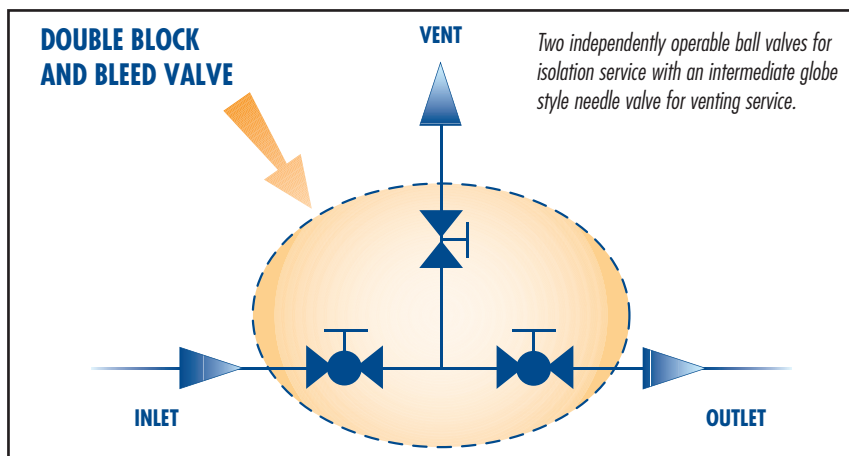

DOUBLE BLOCK AND BLEED MAIN FUNCTIONS

INSTRUMENT DOUBLE BLOCK AND BLEED FOR CHEMICAL INJECTION & SAMPLING	Double Block and Bleed valves for chemical injection & sampling require an additional straight tubing onto the bore of the valve inlet flange face. This quill enters into the process flow and chemicals can be introduced through the valve. Incorporated in the valve design an additional check valve is required for this application in order to prevent reverse flow and process fluid contaminating the chemical source. For sampling the reverse is applied.
INSTRUMENT DOUBLE BLOCK AND BLEED FOR PRESSURE CONNECTIONS	Double Block and Bleed valves for pressure connections are generally used to isolate instrumentation such as pressure indicators and lever gauges.
IN-LINE DOUBLE BLOCK AND BLEED FOR PROCESS ISOLATION	Double Block and Bleed valves for process isolation are located in the primary process stream.

DOUBLE BLOCK AND BLEED VALVE - ASME CLASS 150

FULL BORE DESIGN - FLANGED ENDS

SIZE Inch	Valve Type	A1 (RF)	A2 (RJ)	B	C	H	Weight Kg	Figure N°
1/2"	FLOATING	208	—	14	225	110	8,5	1-E333R
3/4"	FLOATING	215	—	20	228	112	9,5	1-E444R
1"	FLOATING	230	240	25,4	233	116	12	1-E555R
1-1/2"	FLOATING	282	292	38	305	135	18	1-E777R
2"	FLOATING	330	340	49	310	145	23	1-E888R
3"	FLOATING	390	400	76	520	190	43	1-EMMMR
4"	FLOATING	440	450	100	535	210	83	1-ENNNR
6"	FLOATING	630	640	150	870	260	149	1-EPPPR
8"	TRUNNION	830	840	202	—	280	440	1-FQQQR

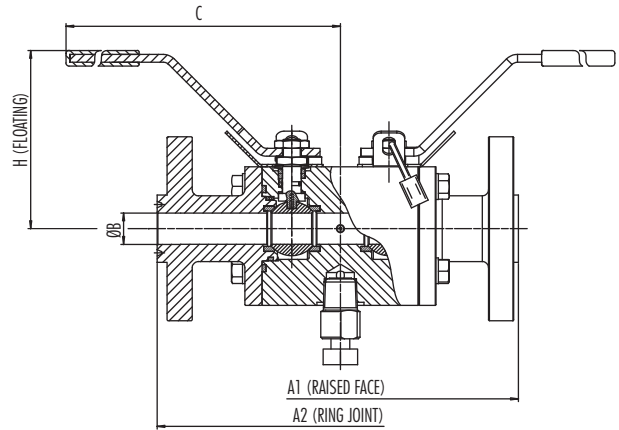
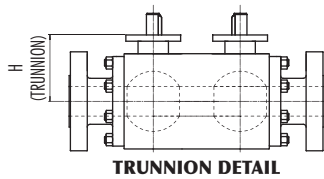

REDUCED BORE DESIGN - FLANGED ENDS

SIZE Inch	Valve Type	A1 (RF)	A2 (RJ)	B	B1	C	H	Weight Kg	Figure N°
3/4"	FLOATING	212	—	14	20	225	110	10	1-E434R
1"	FLOATING	219	229	20	25,4	228	112	11,5	1-E545R
1-1/2"	FLOATING	237	247	25,4	38	233	116	16	1-E757R
2"	FLOATING	286	296	38	49	305	135	22	1-E878R
3"	FLOATING	340	350	49	76	310	145	29	1-EM8MR
4"	FLOATING	390	400	76	100	520	190	50	1-ENMNR
6"	FLOATING	444	454	100	150	535	210	98	1-EPNPR
8"	FLOATING	636	646	150	202	870	260	160	1-EQPQR

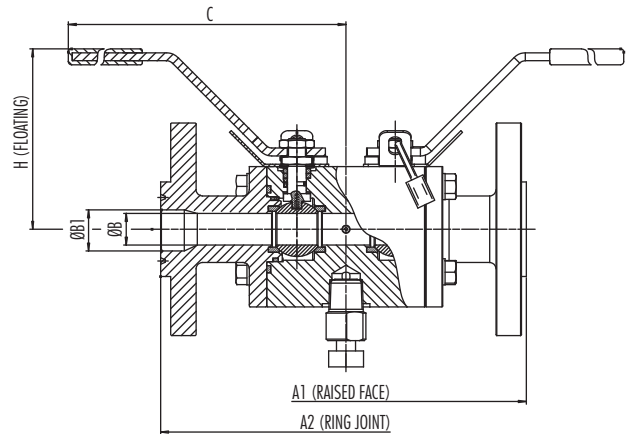

FLANGED INLET - 1/2" FEMALE NPT THREADED OUTLET

SIZE Inch	Valve Type	A1 (RF)	A2 (RJ)	B	B1	C	H	Weight Kg	Figure N°
1/2"	FLOATING	178	—	14	14	225	110	8	1-E333X
3/4"	FLOATING	180	—	14	20	225	110	8,5	1-E433X
1"	FLOATING	182	187	14	25,4	225	110	10	1-E533X
1-1/2"	FLOATING	184	189	14	38	225	110	13	1-E733X
2"	FLOATING	186	191	14	49	225	110	16	1-E833X
3"	FLOATING	191	201	14	76	225	110	21	1-EM33X

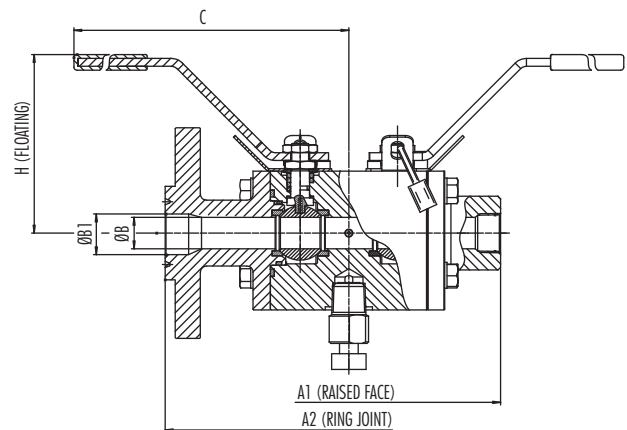

DOUBLE BLOCK AND BLEED VALVE - ASME CLASS 300

FULL BORE DESIGN - FLANGED ENDS

SIZE Inch	Valve Type	A1 (RF)	A2 (RJ)	B	C	H	Weight Kg	Figure N°
1/2"	FLOATING	214	224	14	225	110	9,5	3-E333R
3/4"	FLOATING	221	231	20	228	112	10,5	3-E444R
1"	FLOATING	238	248	25,4	233	116	13	3-E555R
1-1/2"	FLOATING	288	298	38	305	135	22	3-E777R
2"	FLOATING	336	348	49	310	145	28	3-E888R
3"	FLOATING	400	412	76	520	190	52	3-EMMR
4"	FLOATING	465	477	100	535	210	114	3-ENNR
6"	TRUNNION	720	732	151	-	250	320	3-FPPPR
8"	TRUNNION	880	892	202	-	280	482	3-FQQQR

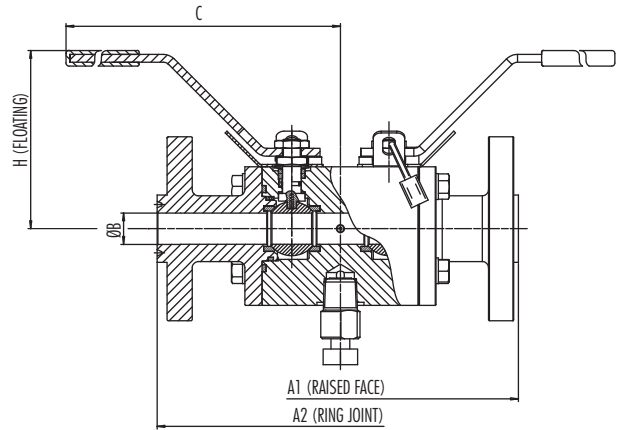
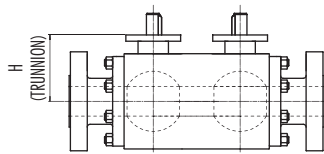

REDUCED BORE DESIGN - FLANGED ENDS

SIZE Inch	Valve Type	A1 (RF)	A2 (RJ)	B	B1	C	H	Weight Kg	Figure N°
3/4"	FLOATING	218	228	14	20	225	110	11,5	3-E434R
1"	FLOATING	225	235	20	25,4	228	112	13	3-E545R
1-1/2"	FLOATING	246	256	25,4	38	233	116	18	3-E757R
2"	FLOATING	292	298	38	49	305	135	27	3-E878R
3"	FLOATING	348	360	49	76	310	145	35	3-EM8MR
4"	FLOATING	408	420	76	100	520	190	60	3-ENMR
6"	FLOATING	475	487	100	150	535	210	130	3-EPNPR
8"	TRUNNION	740	752	151	202	-	250	354	3-FQPQR

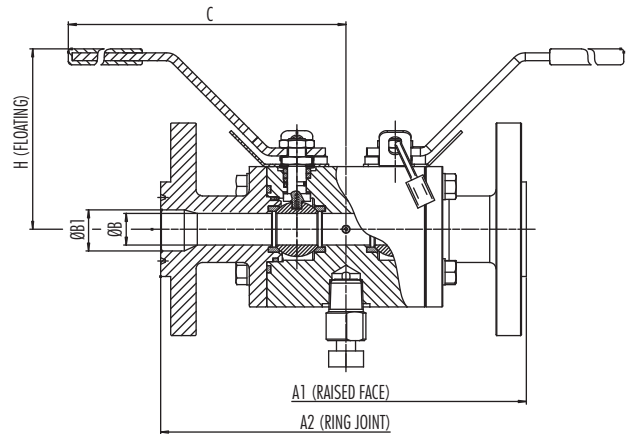
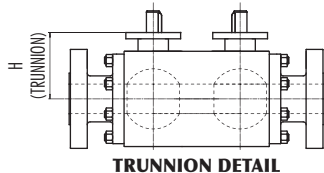

FLANGED INLET - 1/2" FEMALE NPT THREADED OUTLET

SIZE Inch	Valve Type	A1 (RF)	A2 (RJ)	B	B1	C	H	Weight Kg	Figure N°
1/2"	FLOATING	181	185	14	14	225	110	8,5	3-E333X
3/4"	FLOATING	183	188	14	20	225	110	9	3-E433X
1"	FLOATING	185	190	14	25,4	225	110	10,5	3-E533X
1-1/2"	FLOATING	188	193	14	38	225	110	13,5	3-E733X
2"	FLOATING	190	196	14	49	225	110	17	3-E833X
3"	FLOATING	197	203	14	76	225	110	22,5	3-EM33X

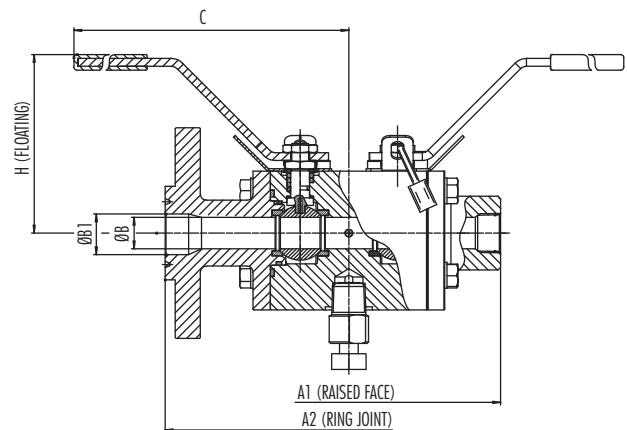

DOUBLE BLOCK AND BLEED VALVE - ASME CLASS 600

FULL BORE DESIGN - FLANGED ENDS

SIZE Inch	Valve Type	A1 (RF)	A2 (RJ)	B	C	H	Weight Kg	Figure N°
1/2"	FLOATING	228	226	14	225	110	10	6-E333R
3/4"	FLOATING	234	234	20	228	112	11	6-E444R
1"	FLOATING	252	252	25,4	233	116	14	6-E555R
1-1/2"	FLOATING	325	325	38	305	135	24	6-E777R
2"	FLOATING	353	356	49	310	145	31	6-E888R
3"	FLOATING	462	465	76	520	190	57	6-EMMMR
4"	TRUNNION	697	700	101	-	197	240	6-FNNNR
6"	TRUNNION	877	880	151	-	250	420	6-FPPPR
8"	TRUNNION	1050	1053	202	-	290	670	6-FQQQR

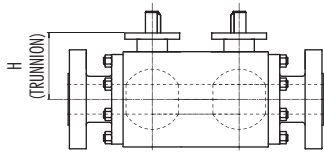

TRUNNION DETAIL

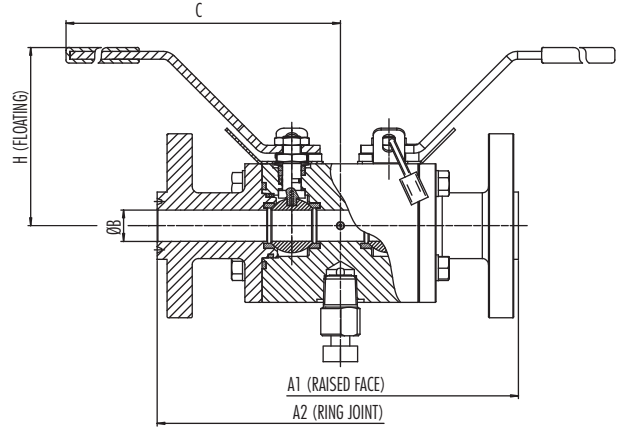

REDUCED BORE DESIGN - FLANGED ENDS

SIZE Inch	Valve Type	A1 (RF)	A2 (RJ)	B	B1	C	H	Weight Kg	Figure N°
3/4"	FLOATING	230	230	14	20	225	110	13	6-E434R
1"	FLOATING	238	238	20	25,4	228	112	14,5	6-E545R
1-1/2"	FLOATING	262	262	25,4	38	233	116	20	6-E757R
2"	FLOATING	332	338	38	49	305	135	30	6-E878R
3"	FLOATING	368	371	49	76	310	145	40	6-EM8MR
4"	FLOATING	477	480	76	100	520	190	66	6-ENMNR
6"	TRUNNION	727	730	101	151	-	197	280	6-FPNPR
8"	TRUNNION	907	910	151	202	-	250	470	6-FQPQR

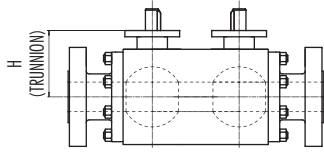

TRUNNION DETAIL

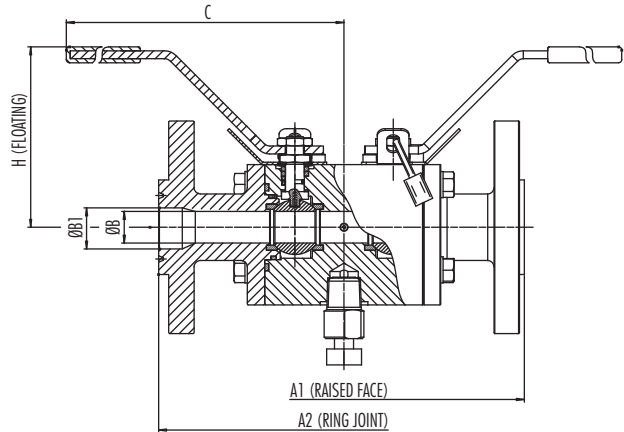

FLANGED INLET - 1/2" FEMALE NPT THREADED OUTLET

SIZE Inch	Valve Type	A1 (RF)	A2 (RJ)	B	B1	C	H	Weight Kg	Figure N°
1/2"	FLOATING	188	187	14	14	225	110	9	6-E333X
3/4"	FLOATING	189	189	14	20	225	110	9,5	6-E433X
1"	FLOATING	191	191	14	25,4	225	110	11	6-E533X
1-1/2"	FLOATING	196	196	14	38	225	110	14	6-E733X
2"	FLOATING	199	200	14	49	225	110	18	6-E833X
3"	FLOATING	206	207	14	76	225	110	24	6-EM33X

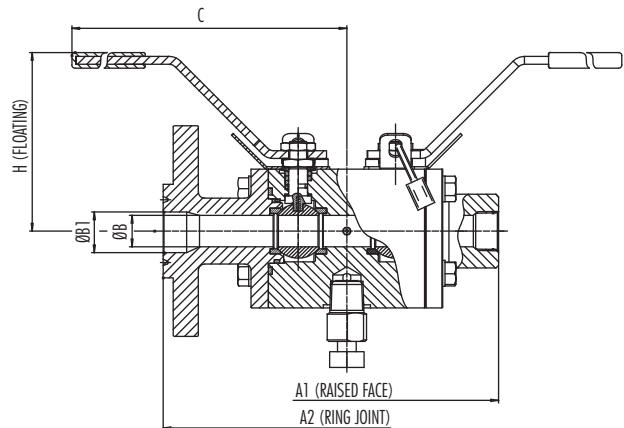

DOUBLE BLOCK AND BLEED VALVE - ASME CLASS 900

FULL BORE DESIGN - FLANGED ENDS

SIZE Inch	Valve Type	A1 (RF)	A2 (RJ)	B	C	H	Weight Kg	Figure N°
1/2"	FLOATING	276	276	11,1	225	112	13	90H E333R
3/4"	FLOATING	287	287	15,5	228	114	16	90H E444R
1"	FLOATING	330	330	21	295	122	21	90H E555R
1-1/2"	FLOATING	400	400	34	410	155	46	90H E777R
2"	FLOATING	464	467	43	415	162	63	90H E888R
3"	TRUNNION	647	650	75	-	180	150	90H FMMMR
4"	TRUNNION	747	750	101	-	220	315	90H FNNNR
6"	TRUNNION	977	980	151	-	260	775	90H FPPPR
8"	TRUNNION	1197	1200	202	-	300	1330	90H FQQQR

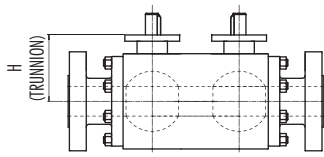

TRUNNION DETAIL

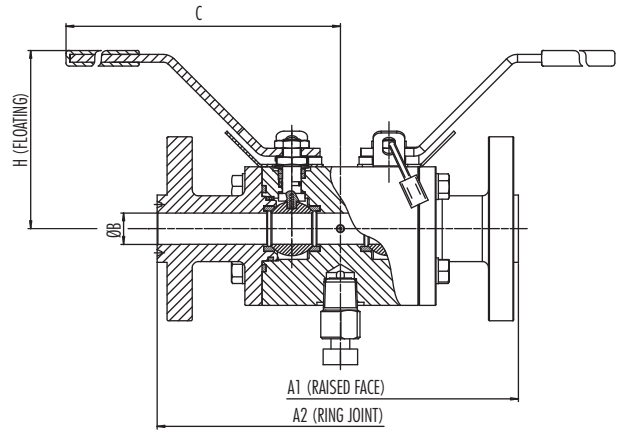

REDUCED BORE DESIGN - FLANGED ENDS

SIZE Inch	Valve Type	A1 (RF)	A2 (RJ)	B	B1	C	H	Weight Kg	Figure N°
1/2"	FLOATING	282	282	11,1	15,5	225	112	16	90H E434R
1"	FLOATING	295	295	15,5	21	228	114	19	90H E545R
1-1/2"	FLOATING	340	340	21	34	295	122	28	90H E757R
2"	FLOATING	412	415	34	43	410	155	55	90H E878R
3"	FLOATING	442	445	43	65	415	162	75	90H EM8MR
4"	TRUNNION	662	665	75	101	-	180	180	90H FNMNR
6"	TRUNNION	772	775	101	151	-	220	390	90H FPNPR
8"	TRUNNION	1017	1020	151	202	-	260	870	90H FQPQR

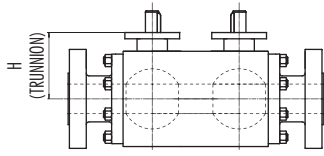

TRUNNION DETAIL

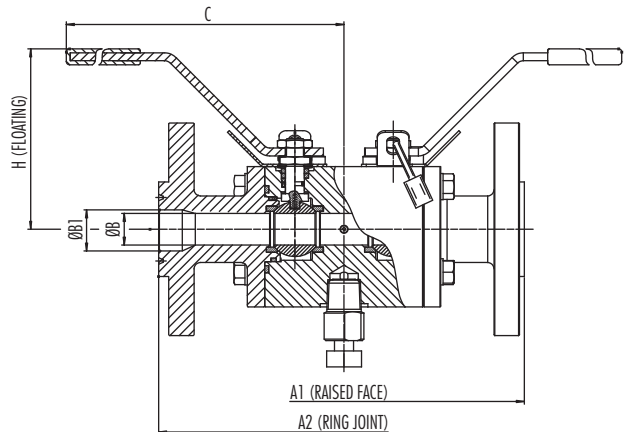

FLANGED INLET - 1/2" FEMALE NPT THREADED OUTLET

SIZE Inch	Valve Type	A1 (RF)	A2 (RJ)	B	B1	C	H	Weight Kg	Figure N°
1/2"	FLOATING	221	221	11,1	11,1	225	112	11	90H E333X
3/4"	FLOATING	224	224	11,1	15,5	225	112	12	90H E433X
1"	FLOATING	231	231	11,1	21	225	112	13	90H E533X
1-1/2"	FLOATING	235	235	11,1	34	225	112	17	90H E733X
2"	FLOATING	239	240	11,1	43	225	112	22	90H E833X
3"	FLOATING	244	245	11,1	65	225	112	30	90H EM33X

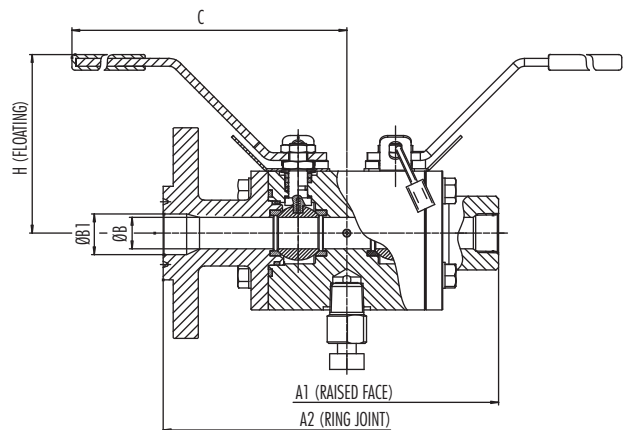

DOUBLE BLOCK AND BLEED VALVE - ASME CLASS 1500

FULL BORE DESIGN - FLANGED ENDS

SIZE Inch	Valve Type	A1 (RF)	A2 (RJ)	B	C	H	Weight Kg	Figure N°
1/2"	FLOATING	276	276	11,1	225	112	13	15H E333R
3/4"	FLOATING	287	287	15,5	228	114	16	15H E444R
1"	FLOATING	330	330	21	295	122	21	15H E555R
1-1/2"	FLOATING	400	400	34	410	155	46	15H E777R
2"	FLOATING	464	467	43	415	162	63	15H E888R
3"	TRUNNION	697	700	75	-	180	170	15H FMMMR
4"	TRUNNION	827	830	101	-	220	340	15H FNNNR
6"	TRUNNION	1084	1090	145	-	270	820	15H FPPPR
8"	TRUNNION	1340	1350	193	-	310	1400	15H FQQQR

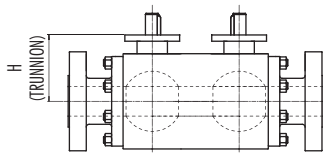

TRUNNION DETAIL

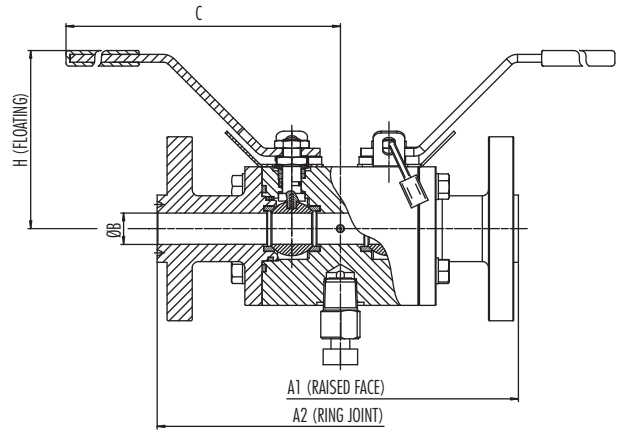

REDUCED BORE DESIGN - FLANGED ENDS

SIZE Inch	Valve Type	A1 (RF)	A2 (RJ)	B	B1	C	H	Weight Kg	Figure N°
3/4"	FLOATING	282	282	11,1	15,5	225	112	16	15H E434R
1"	FLOATING	295	295	15,5	21	228	114	19	15H E545R
1-1/2"	FLOATING	340	340	21	34	295	122	28	15H E757R
2"	FLOATING	412	415	34	43	410	155	55	15H E878R
3"	FLOATING	452	455	43	65	415	162	80	15H E88MR
4"	TRUNNION	737	740	75	101	-	180	210	15H FNMNR
6"	TRUNNION	894	900	101	145	-	220	430	15H FPNPR
8"	TRUNNION	1120	1130	145	193	-	270	940	15H FQPQR

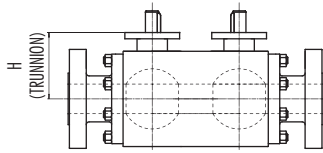

TRUNNION DETAIL

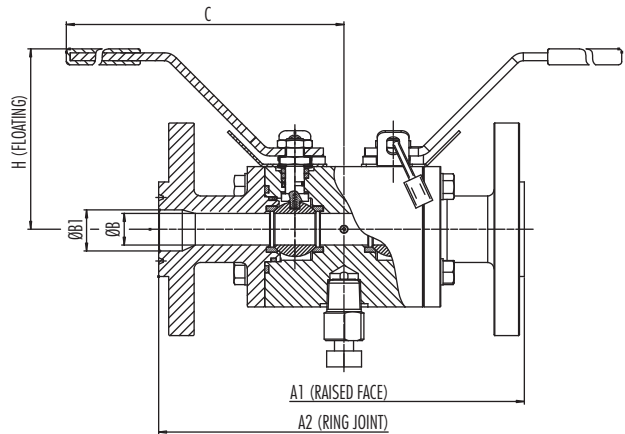

FLANGED INLET - 1/2" FEMALE NPT THREADED OUTLET

SIZE Inch	Valve Type	A1 (RF)	A2 (RJ)	B	B1	C	H	Weight Kg	Figure N°
1/2"	FLOATING	221	221	11,1	11,1	225	112	11	15H E333X
3/4"	FLOATING	224	224	11,1	15,5	225	112	12	15H E433X
1"	FLOATING	231	231	11,1	21	225	112	13	15H E533X
1-1/2"	FLOATING	235	235	11,1	34	225	112	17	15H E733X
2"	FLOATING	239	240	11,1	43	225	112	22	15H E833X
3"	FLOATING	254	255	11,1	65	225	112	33	15H EM33X

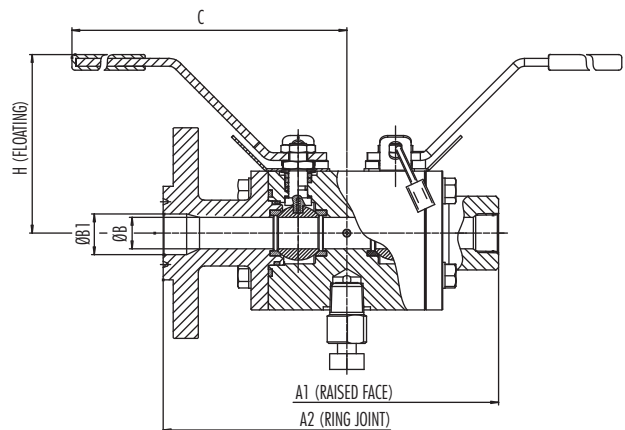

DOUBLE BLOCK AND BLEED VALVE - ASME CLASS 2500

FULL BORE DESIGN - FLANGED ENDS

SIZE Inch	Valve Type	A1 (RF)	A2 (RJ)	B	C	H	Weight Kg	Figure N°
1/2"	FLOATING	291	291	11,1	225	112	16	25H E333R
3/4"	FLOATING	300	300	15,5	228	114	19	25H E444R
1"	FLOATING	350	350	21	295	122	35	25H E555R
1-1/2"	TRUNNION	565	565	32	-	100	90	25H F777R
2"	TRUNNION	652	655	43	-	125	150	25H F888R
3"	TRUNNION	864	870	63	-	190	340	25H FMMMR
4"	TRUNNION	990	1000	88	-	240	660	25H FNNNR
6"	TRUNNION	1317	1330	131	-	280	1390	25H FPPPR
8"	TRUNNION	1484	1500	179	-	380	2480	25H FQQQR

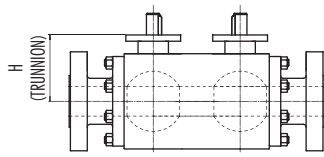

TRUNNION DETAIL

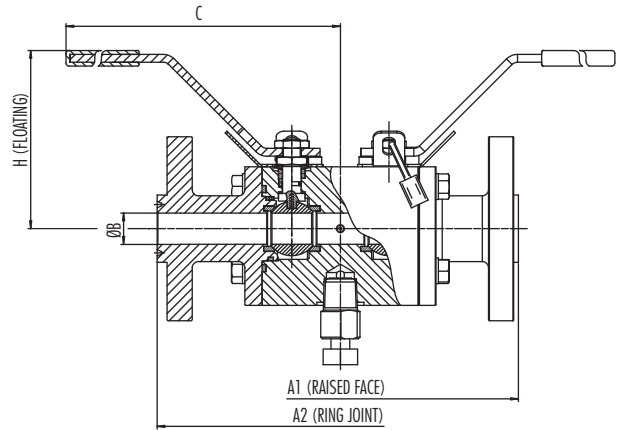

REDUCED BORE DESIGN - FLANGED ENDS

SIZE Inch	Valve Type	A1 (RF)	A2 (RJ)	B	B1	C	H	Weight Kg	Figure N°
1/2"	FLOATING	294	294	11,1	15,5	225	112	19	25H E434R
1"	FLOATING	310	310	15,5	21	228	114	22	25H E545R
1-1/2"	FLOATING	370	373	21	34	295	122	45	25H E757R
2"	TRUNNION	577	580	32	43	-	100	110	25H F878R
3"	TRUNNION	694	700	43	63	-	125	210	25H FM8MR
4"	TRUNNION	890	900	63	88	-	190	440	25H FNMNR
6"	TRUNNION	1067	1080	88	131	-	240	800	25H FPNPR
8"	TRUNNION	1384	1400	131	179	-	280	1750	25H FQPQR

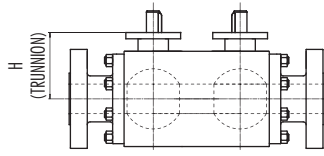

TRUNNION DETAIL

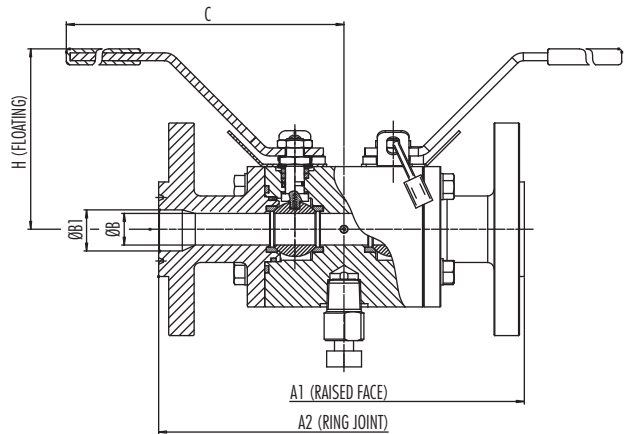

FLANGED INLET - 1/2" FEMALE NPT THREADED OUTLET

SIZE Inch	Valve Type	A1 (RF)	A2 (RJ)	B	B1	C	H	Weight Kg	Figure N°
1/2"	FLOATING	228	228	11,1	11,1	225	112	13	25H E333X
3/4"	FLOATING	230	230	11,1	15,5	225	112	14	25H E433X
1"	FLOATING	234	234	11,1	21	225	112	15	25H E533X
1-1/2"	FLOATING	244	245	11,1	34	225	112	20	25H E733X
2"	FLOATING	252	253	11,1	43	225	112	27	25H E833X
3"	FLOATING	267	270	11,1	65	225	112	41	25H EM33X

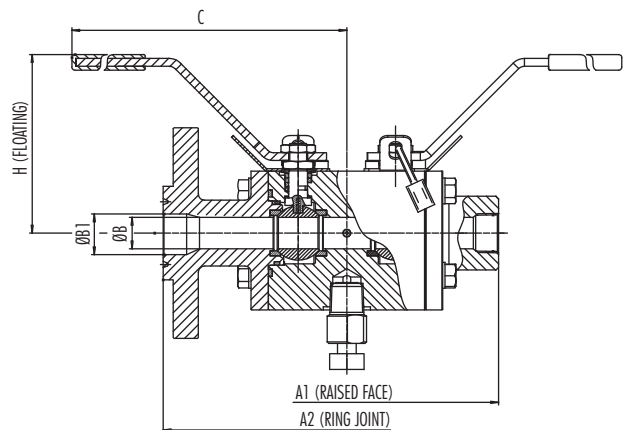

VALVE SEAT & GASKET MATERIAL SELECTION GUIDE

SEAT PRESSURE/TEMPERATURE RATING

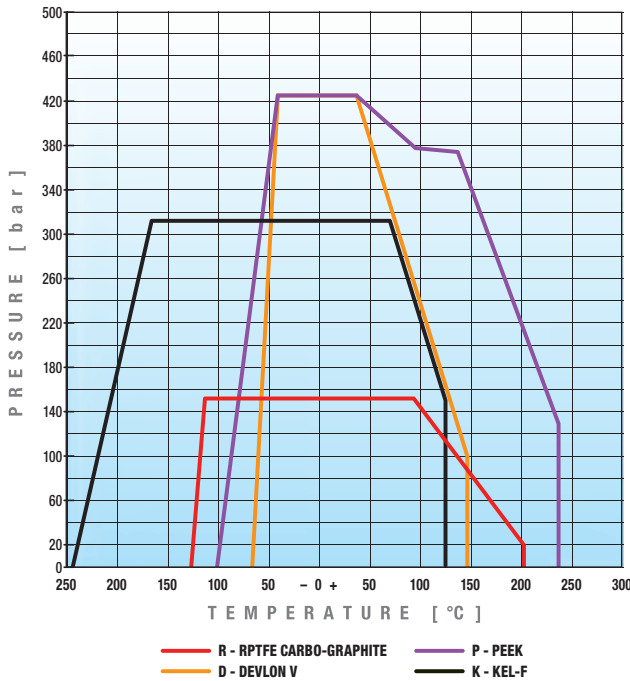

PLEASE NOTE THAT THE FOLLOWING RATINGS ARE REFERRED TO THE VALVE SEATS. DO NOT USE THIS RATINGS FOR THE VALVE CLASS SELECTION.

Choosing the right seat material is the most important decision in ball valve selection. Use the Pressure/Temperature rating chart for the most common seat materials and ask us in case of special material or applications.

The BFE SEAL CODE (3 digits) is designed to cover essential features of BFE seats and gasket material, the code is marked on the valve nameplate in order to easily allow customers to identify the internal soft material.

- DIGIT-1 – INSERT SEAT MATERIAL
- DIGIT-2 – EMERGENCY BODY SEAL
- DIGIT-3 – FIRST BODY SEAL

Example: SEAL CODE "RGR":

INSERT SEAT MATERIAL = RPTFE CARBO-GRAPHITE

EMERGENCY BODY SEAL = GRAPHITE

FIRST BODY SEAL = RPTFE CARBO-GRAPHITE.

The following table shows the most used materials, their characteristics, application (seat or gasket) and the BFE ID.

SEAL MATERIAL	MATERIALS CHARACTERISTICS	BFE SYMBOL	AVAILABLE MATERIAL FOR SEAT	AVAILABLE MATERIAL FOR GASKET
			BFE SEAL CODE DIGIT 1	BFE SEAL CODE DIGIT 2/3
VIRGIN PTFE	Polytetrafluoroethylene is a Fluorocarbon-based polymer. This seating material has excellent chemical resistance and low coefficient of friction. PTFE is non-contaminating and accepted by FDA for use in food services. Not recommended for liquid alkalis and fluorine.	M	YES	YES
RPTFE 25% CARBO-GRAPHITE	PTFE's mechanical properties are enhanced by adding percentage of filler material to provide improved strength, stability and wear resistance.	R	YES	YES
RPTFE 60% BRONZE	This material exhibits a unique combination of heat resistance and low friction together with outstanding chemical and good electrical properties. No moisture absorption, high arc resistance, and is self lubricating with a low coefficient of friction.	B	YES	NO
DEVLON-V	Devlon-V (special Nylon produced by Deval Engineering Ltd) offers very good performances regarding the maximum allowable pressure and excellent elasticity.	D	YES	NO
KEL-F	PCFEE (Polychlorotrifluoroethylene) is a fluorocarbon based polymer. It offers a unique combination of physical and mechanical properties non-flammability, chemical resistance, and near zero moisture absorption. It is suitable for cryogenic applications.	K	YES	NO
PEEK	Polyetheretherketone high temperature semi rigid elastomer. Best suited for high pressure and temperature service. Also offers very good corrosion resistance.	P	YES	NO
UHMWP	Ultra-High Molecular Weight Polyethylene. Ideal for use in lowlevel radiation service. This seat also meets the requirements of the tobacco industry where TFE is prohibited and it offers an excellent resistance to abrasive media.	U	YES	YES
VITON A	Standard material for O-RING	V	YES	YES
VITON GLT	Viton GLT is a fluoroelastomer designed to retain the high heat and the chemical resistance of general use grades of Viton fluoroelastomer, while improving the low temperature flexibility of the material. Glass transition temperatures of materials are indicative of low temperature performance in typical elastomer applications	L	YES	YES
HNBR	Hydrogenated nitrile rubber (HNBR) has excellent mechanical, thermo-oxidative and chemical resistant properties and an excellent operating temperature range.	H	YES	NO
GRAPHITE	Hard carbon with excellent heat resistance. Not suitable as seat material when presence of oxidized service is expected.	G	YES	YES
TUNGSTEN CARBIDE COAT	For liquid or gas services with high presence of solids or in any case where extreme hardness and wear resistance is required. Tungsten carbide itself is practically inert and extremely strong. Any attack is usually on the binder. Not suitable when small presence of caustic soda is expected.	W	YES	N.A.
CHROME CARBIDE COAT	For liquid or gas services with small presence of solids. Not suitable when small presence of caustic soda is expected.	C	YES	N.A.
OTHER	For other materials please ask to BFE.	-	-	-

GENERAL SALE CONDITIONS

QUOTATION VALIDITY

Unless otherwise agreed, quotations are valid for four weeks from date of issue.

The delivery terms are always "ex-works" unless otherwise stated.

Prices and sale conditions can be changed without any previous notice.

ORDERS ACCEPTANCE

Orders are considered accepted at our general sale conditions clearly mentioned on order acknowledgment.

GOODS DELIVERY

The Company does not accept any responsibility for delays in delivery which are always intended as indicative and not binding. Transport risks are at receiver's charge also in case of CIF delivery.

GUARANTEE

The Company warrants all its products, from material and/or manufacturing defects, to be used as recommended by standards, and in accordance with approved piping practice and technique, for a period of one year from shipping date, unless otherwise agreed.

The Company liability covers eventual "free of charge" replacements for defective parts or products, providing it has not failed in the observance of above mentioned conditions and in use in compliance with standards, and, anyway, after return of defective goods. Any other liability, neither objective nor subjective will be accepted.

CLAIMS AND ORDER CANCELLATIONS

Claims will be considered only if made within 10 days from goods receipt.

Partial or complete cancellations of order can be accepted only upon previous agreement or by written consent and, however, not later than 15 days from order date.

Any controversy will be handled by the Court of Milan.

Dimensions on the catalogue are indicative.
B.F.E. S.r.l. reserves the right to make all necessary changes without notice.





B.F.E. S.r.l. - Via Tonale, 70/A - 24061 Albano S.Alessandro (BG) Italy - Phone: 035.584111 - Fax: 035.583022 - Mail: sales@bfe.it
www.bfe.it

BONNEY FORGE



BONNEY FORGE
+001.814.542.2545
www.bonneyforge.com



+001.713.695.3633 - +001.713.695.3528 f
www.wfi-intl.com



www.rpc-valve.com